

CATALOG 22-A 1955



ELECTRONIC MEASURING INSTRUMENTS

HEWLETT-PACKARD COMPANY | 275 PAGE MILL ROAD, PALO ALTO, CALIFORNIA, U. S. A.

Oscillators — .008 cps to 10 MC

Instrument	Primary Uses	Frequency Range	Output	Price	Page
-hp- 200AB	Audio tests	20 cps to 40 KC	1 watt/24.5 v	\$120.00	8, 9
-hp- 200CD	Audio and ultrasonic tests	5 cps to 600 KC	160 mw/20 v open circuit	150.00	8, 9
-hp- 200 I	Interpolation, frequency measurements	6 cps to 6 KC	100 mw/10 v	225.00	8, 9
-hp- 200T	Telemetry, carrier current tests	250 cps to 100 KC	160 mw or 10v/600 ohms; 20 v open circuit	350.00	8, 9
-hp- 201B	High quality audio tests	20 cps to 20 KC	3 w/42.5 v	250.00	12
-hp- 202A	Low frequency measurements	.008 to 1200 cps	20 mw/10 v	465.00△	10, 11
-hp- 202B	Low frequency measurements	1/2 cps to 50 KC	100 mw/10 v	365.00△	13
-hp- 205AG	High power tests, gain measurements	20 cps to 20 KC	5 watts	440.00△	18, 19
-hp- 206A	High quality, high accuracy audio tests	20 cps to 20 KC	+ 15 dbm	565.00△	20, 21
-hp- 233A	Carrier test oscillator	50 cps to 500 KC	3 w/600 ohms	475.00	16
-hp- 450A	Wide range video tests	10 cps to 10 MC	15 mw/3 v	490.00△	14, 15

Vacuum Tube Voltmeters — 10 cps to 700 MC

Instrument	Primary Uses	Frequency Range	Voltage Range	Input Impedance	Price	Page
-hp- 400AB	General purpose ac measurements	10 cps to 600 KC	0.003 to 300 v 11 ranges	10 megohms 25 μmf shunt	\$200.00	36
-hp- 400D	Wide range ac measurements High sensitivity	10 cps to 4 MC	0.001 to 300 v 12 ranges	10 megohms 15 μmf shunt	225.00	32, 33
-hp- 410B	Audio, rf, VHF measurements; dc voltages; resistances	20 cps to 700 MC	0.1 to 300 v 7 ranges	10 megohms 1.5 μmf shunt	245.00	34, 35

Voltmeter Accessories

Extend usefulness of -hp- Models 400AB, D or 410B voltmeters

Instrument	Features	Price	Page
-hp- 452A Capacitive Voltage Divider	For all -hp- ac VTVM. 25 cps to 20 MC. Division 1000:1	\$100.00	37
-hp- 452-95A Adapter	Connects -hp- 452A to -hp- 410B VTVM probe	10.00	37
-hp- 453A Capacitive Voltage Divider	For -hp- 410B VTVM only Division 100:1	25.00	37
-hp- 454A Capacitive Voltage Divider	For -hp- 400D VTVM only. Division 100:1	25.00	37
-hp- 455A Probe Coaxial "T" Connector	For -hp- 410B VTVM. Measures voltages between conductor and sheath of 50 ohm transmission line.	35.00	37
-hp- 458A Probe Coaxial "N" Connectors	For -hp- 410B VTVM. Measures volts at open end of 50 ohm transmission line.	25.00	37
-hp- 459A DC Resistive Voltage Multiplier	For -hp- 410B VTVM. For measuring high dc voltages safely. Multiplies 1:100	25.00	37
-hp- 470 A-F Shunt Resistors	For -hp- 400AB, or D VTVM. For measurement of current.	470A - 15.00 470B-F - 7.50	37

Frequency Measuring, Monitoring Equipment

Instrument	Primary Uses	Frequency Range	Characteristics	Price	Page
-hp- 100D Secondary Standard	Frequency, time measurements	100 KC, 10 KC, 1 KC, 100 cps, 10 cps	Stability 1/1,000,000 (short-time) Sine or rectangular output. Marker pips	\$ 615.00△	46, 47
-hp- 335B Frequency Monitor	FM broadcast station monitor	88 to 108 MC	Frequency deviation ±3 KC; accuracy ±.001% modulation 0 to 100 KC	935.00	50, 51
-hp- 335E TV Monitor	Aural and visual monitoring; black and white or color	Channels 2 to 83	Aural deviation ±3KC; video deviation ±3 KC; accuracy ±500 cps approx.	2,050.00	50, 51
-hp- 500B Electronic Frequency Meter	Rapid frequency measurements	1 cps to 100 KC	9 ranges ±2% accuracy. Input 0.2 to 250 volts	285.00	48, 49
-hp- 500C Electronic Frequency Meter	rpm measurements	60 to 6,000,000 rpm	Similar to 500B but calibrated in rpm	285.00	48, 49
-hp- 506A Optical Tachometer Pickup	rps and rpm measurement	300 to 300,000 rpm	Phototube and light source; output 1 v rms	100.00	52
-hp- 508A Tachometer Generator	Shaft speed measurement	15 to 40,000 rpm	Output 60 cycles per revolution	100.00	52
-hp- 508B Tachometer Generator	Shaft speed measurement	15 to 40,000 rpm	Output 100 cycles per revolution	100.00	52
-hp- 512A Frequency Converter	Extend range of -hp- 524A Counter	10 to 100 MC	High sensitivity, 50 ohm impedance; 0.01 v rms min. input	350.00	61
-hp- 512B Frequency Converter	Extend range of -hp- 524A Counter	100 to 220 MC	Similar but requires 0.14 v rms min. input	350.00	61
-hp- 520A Nuclear Scaler	For counting high-rate pulses	Capacity 100 counts in 2 decades. 10,000,000 pps counting rate	100:1 divider for operation of low speed scalars	615.00△	62
-hp- 521A Industrial Electronic Counter	Measure frequency, speed, time interval	1 cps to 120 KC	Direct reading, accurate within ±1 count ±0.1%, 4 place registration	425.00	59
-hp- 522B Electronic Counter	Frequency, period, time interval measurements	10 cps to 100 KC	Direct reading, accuracy ± 1 count ±0.001%	915.00△	54, 55
-hp- 524B Frequency Counter	Frequency, period measurements	.01 cps to 10 MC	Direct reading, no interpolation, accuracy about 2/1,000,000/week	2,150.00 ■	56, 57, 58
-hp- 525A Frequency Converter	Extends 524B's range to 100 MC; increases basic sensitivity	10 cps to 100 MC	Accuracy ± 1 cps ± stability; 0.1 v rms min. input	250.00	57, 58
-hp- 525B Frequency Converter	Extends 524B's range from 100 to 220 MC; high sensitivity	100 MC to 220 MC	Same as 525A	250.00	57, 58
-hp- 526A Video Amplifier	Increases 524B's sensitivity to 10 millivolts	10 cps to 10 MC	Accuracy same as basic counter; 10 mv rms min. input	150.00	57, 58
-hp- 526B Time Interval Unit	Measures interval 1 μsec to 100 days	1 μsec to 10 ⁷ sec	Accurate 0.1 μsec ±0.0001%	175.00	57, 58



INDEX BY INSTRUMENT TYPE AND FUNCTION



Signal Generators—10 to 11,000 MC

Instrument	Frequency Range	Characteristics	Price	Page
-hp- 608C	10 to 480 MC	Output 0.1 μ v to 1 v into 50 ohm load. Pulse or CW modulation Direct calibration.	\$ 950.00	66, 67
-hp- 608D	10 to 420 MC	Output 0.1 μ v to 0.5 v. Incidental FM 0.002 entire range.	1,050.00	66, 67
-hp- 612A	450 to 1,200 MC	Output 0.1 μ v to 0.5 v into 50 ohm load. Pulse, CW or square wave modulation. Direct calibration.	1,200.00	68, 69
-hp- 614A	800 to 2,100 MC	Output 0.1 μ v to 0.223 v into 50 ohm load. Pulse, CW or FM modulation. Direct calibration.	1,950.00	70, 71
-hp- 616A	1,800 to 4,000 MC	Output 0.1 μ v to 0.223 v into 50 ohm load. Pulse, CW or FM modulation. Direct calibration.	1,950.00	70, 71
-hp- 618B	3,800 to 7,600 MC	Output 0.1 μ v to 0.223 v into 52 ohm load. Pulse, CW, FM or square wave modulation. Direct calibration.	2,250.00	72, 73
-hp- 620A	7,000 to 11,000 MC	Output 0.1 μ v to 0.071 v into 50 ohm load. Pulse, FM or square wave modulation. Separate power meter and wave meter section.	2,250.00	72, 73
-hp- 623B	5,925 to 7,725 MC	Output 70 μ v to 0.223 v into 50 ohm load. FM or square wave modulation. Separate power meter and wave meter section.	1,750.00	74, 75
-hp- 624C	8,500 to 10,000 MC	Output 3.0 μ v to 0.223 v into 50 ohm load. Pulse, FM or square wave modulation. Separate power meter and wave meter section.	2,265.00 Δ	74, 75
Swept Frequency Oscillator				
-hp- 670HM	7 to 10 KMC	Automatic, adjustable sweep, full "H" band coverage, high output, varied modulation.	850.00 with motor	76, 77

Square Wave and Pulse Generators

Instrument	Primary Uses	Frequency Range	Characteristics	Price	Page
-hp- 211A	Square wave generator	1 cps to 1 MC	Output 7.5 v across 75 ohms or 60 v across 600 ohms	\$265.00	24
-hp- 212A	Pulse generator	50 - 5,000 pps. .02 μ sec rise time	Pulse length 0.07 to 10 μ sec, output 50 v to 50 ohm load	565.00 Δ	22, 23

Other Instruments and Accessories

Instrument	Primary Uses	Frequency Range	Characteristics	Price	Page
-hp- 350A/B Attenuator	Measurement of attenuation, gain	0 to 100 KC	110 db in 1 db steps. A—500 ohm level; B—600 ohm level	\$ 60.00	30
-hp- 360A-D Low Pass Filters	Eliminates harmonic voltages from uhf systems	Cutoff frequencies A- 700 MC C-2,200 MC B-1,200 MC D-4,100 MC	50 db rejection at 1.2 cutoff freq.	40.00	86
-hp- 450A Amplifier, Stabilized	General purpose lab amplifier	5 cps to 1,000,000 cps	20 and 40 db gain, free response $\pm 1/2$ db	140.00	38
-hp- 460A Amplifier, Wide Band	Wide band, pulse amplification	100 KC to 140 MC	20 db gain, rise time .0026 μ sec	185.00	40, 41
-hp- 460B Amplifier, Fast Pulse	Pulse amplification, high output	100 KC to 140 MC	15 db gain, 125 peak volts	225.00	40, 41
-hp- 46A Accessories	Apply and connect 460A/B amplifiers				41
-hp- 710B Power Supply	General purpose regulated plate and filament supply for lab and field use		100 - 360 volts @ 75 ma	100.00	78
-hp- 711A Laboratory Power Supply	Same as above		0 - 500 volts @ 100 ma	225.00	79
-hp- 712B Power Supply	Same as 710B		0 - 500 volts @ 200 ma	365.00 Δ	80
-hp- 715A Klystron Power Supply	Regulated beam, reflector source for low power klystrons		250 - 400 volts @ 50 ma	300.00	81
-hp- 717A Klystron Power Supply	Powering Type 5721 klystrons		800 - 1,000 volts @ 25 ma	375.00	82
Binding posts, Insulators, Support Pedestals					117
-hp- AC-2A Dual Mount					116
-hp- AC-4A Decade Counters	Special setups or replacement in counters	120 KC counting rate	Plug-in to Standard counters	45.00*	116
-hp- AC-16 Cable Assemblies					118
-hp- AC-17 End Frames					116
-hp- AC-44 Cabinets					116
-hp- AC-60A Line Matching Transformers	Connect balanced system to VTVM, oscillators	5 to 600 KC	Max. level +22 dbm	25.00	117
-hp- AC-60B Bridging Transformer		20 cps to 60 KC	Specifically designed for audio systems. Max. level +15 dbm	35.00	117

* f.o.b. Palo Alto, Calif. Quantity discount quotations available from the factory.

Distortion, Wave Form Analyzers—20 cps to 20 KC

Instrument	Primary Uses	Frequency Range	Characteristics	Price	Page
-hp- 300A	Wave form analyzer	30 cps to 16 KC	Variable selectivity; measuring range 1 mv to 500 v	\$625.00	26, 27
-hp- 330B	Measures total audio distortion	20 cps to 20 KC	Includes input amplifier, VTVM	410.00△	28, 29
-hp- 330C	For FM broadcast measurements	20 cps to 20 KC	Special VU meter to meet F.C.C. requirements	440.00△	29
-hp- 330D	For AM, FM broadcast measurements	20 cps to 20 KC	AM detector and VU meter to meet F.C.C. requirements	455.00△	29

Waveguide Test Equipment—2.6 to 18.0 KMC

Instrument	Coaxial Type N. Conn.	"S"	"G"	"J"	"H"	"X"	"P"	Page
		3" x 1 1/2" 2.6-3.95 KMC.	2" x 1" 3.95-5.85 KMC.	1 1/2" x 3/4" 5.3-8.2 KMC.	1 1/4" x 5/8" 7.05-10.0 KMC.	1" x 1/2" 8.2-12.4 KMC.	.702" x .391" 12.4-18.1 KMC.	
Adapters, Waveguide to Coax		S281A \$75.00	G281A \$55.00	J281A \$50.00	H281A \$45.00	X281A \$35.00		85
Cover to choke flange		S290A \$65.00	G290A \$50.00	J290A \$35.00	H290A \$25.00	X290A \$15.00	P290A \$20.00	85
Attenuators, Fixed 6, 10, 20 db		S370 \$75.00	G370 \$65.00	J370 \$65.00	H370 \$60.00	X370 \$55.00	P370 \$60.00	87
Flap, 25 db max.		S375A \$110.00	G375A \$100.00	J375A \$90.00	H375A \$80.00	X375A \$50.00	P375A \$65.00	87
Calibrated, Variable		S380A \$260.00						
Broad Band, Precision			G382A \$450.00	J382A \$300.00	H382A \$300.00	X382A \$250.00	P382A \$250.00	87
Crystal Detectors	420A \$50.00					X421A \$75.00		106
Detector Mounts	440A† \$85.00	S485A‡ \$125.00	G485B† \$95.00	J485B† \$90.00	H485B† \$85.00	X485B† \$75.00	P485C \$110.00	106, 94
Waveguide Thermistor Mounts			G487A \$95.00	J487A \$90.00	H487A \$80.00	X487A \$75.00		93
Frequency Meters, Reaction				J530A \$120.00	H530A \$120.00	X530A \$120.00	P530A \$150.00	107
Dir. Couplers, Cross Guide: 20, 30 db		S750 \$100.00	G750 \$85.00	J750 \$70.00	H750 \$60.00	X750 \$50.00		108
Dir. Couplers, Multi Hole: 10, 20 db		S752 \$260.00	G752 \$170.00	J752 \$140.00	H752 \$120.00	X752 \$100.00	P752 \$135.00	108
Slotted Sections, Waveguide		S810A* \$450.00	G810B§ \$90.00	J810B§ \$90.00	H810B§ \$90.00	X810B§ \$90.00	P810B§ \$90.00	105
Waveguide Tees, Series		S840A \$100.00	G840A \$85.00	J840A \$65.00	H840A \$50.00	X840A \$35.00	P840A \$40.00	110
Shunt		S841A \$100.00	G841A \$85.00	J841A \$65.00	H841A \$50.00	X841A \$35.00	P841A \$40.00	110
Hybrid		S845A \$130.00	G845A \$115.00	J845A \$100.00	H845A \$75.00	X845A \$50.00	P845A \$55.00	110
Transformers, Slide Screw		S870A \$170.00	G870A \$140.00	J870A \$135.00	H870A \$130.00	X870A \$125.00	P870A \$130.00	111
E - H		S880A \$225.00	G880A \$155.00	J880A \$145.00	H880A \$135.00	X880A \$130.00	P880A \$135.00	111
Waveguide Phase Shifter				J885A \$300.00	H885A \$300.00	X885A \$250.00	P885A \$250.00	112
Waveguide Horn						X890A \$25.00	P890A \$30.00	113
Terminations, Low Power		S910A \$45.00	G910A \$40.00	J910A \$35.00	H910A \$30.00	X910A \$25.00	P910A \$30.00	113
Terminations, High Power		S912A \$125.00				X912A \$75.00		113
Moving Load		S914A \$100.00	G914A \$75.00	J914A \$70.00	H914A \$60.00	X914A \$50.00	P914A \$55.00	114
Waveguide Standard Reflections						X916 \$100.00		114
Adjustable Shorts		S920A \$80.00	G920A \$70.00	J920A \$65.00	H920A \$60.00	X920A \$50.00	P920A \$55.00	115
Waveguide Shorting Switch						X930 \$60.00		115
Broad Band Probe	442B \$35.00							106
Broad Band Probe, Untuned	444A \$50.00							106
Waveguide Clamps, Stands								117

† For use with bolometer or crystal ‡ For use with bolometer only * Complete assembly including carriage § Mounts in 809B carriage — See next page.

Microwave Test Instruments — for coaxial and waveguide systems

Instrument	Primary Uses	Frequency Range	Characteristics	Price	Page
-hp- 415B Standing Wave Indicator	SWR Indicator or null indicator	300 to 3,000 cps. Normal freq. 1,000 cps	0 to 70 db attn. Max. sensitivity 0.3 μv	\$200.00	102
-hp- 416A Ratio Meter	Reflection coefficient measurements	1,000 cps ±40 cps	Continuous swept frequency presentation; accuracy ±3%	365.00△	98, 99
-hp- 417A vhf Detector	vhf bridge detector (For -hp- 803A)	10 to 500 MC	Approx. 5 μv sensitivity	250.00	101
-hp- 430C Microwave Power Meter	Measurement of rf power	Depends on Bolometer mount	.02 to 10 mw ±5% accuracy	250.00	91
-hp- 475B Tunable Bolometer Mount	Measurement of rf power (with 430B/C)	1,000 to 4,000 MC	Matches 50 ohm line to 100 or 200 ohms	200.00	92
-hp- 476A Universal Bolometer Mount	Measurement of rf power (with 430B/C)	10 to 1,000 MC	No tuning required SWR less than 1.25	85.00	92
-hp- 477A Coaxial Thermistor Mount	Measurement of rf power (with 430B/C)	10 MC to 10 KMC		75.00	93
-hp- 490A Traveling-Wave Tube Amplifier	Amplification throughout "S" band	2 to 4 KMC	35 db gain; millimicrosec rise time; 10 mw output	1,100.00	42, 43
-hp- 491A Traveling-Wave Tube Amplifier	High power "S" band amplification	2 to 4 KMC	30 db gain; millimicrosec rise time; 1 watt output	1,100.00	42, 43
-hp- 803A vhf Bridge	Measurement of vhf impedance, SWR	50 to 500 MC	2 to 2,000 ohms impedance —90° to +90° phase angle	495.00	100, 101
-hp- 805A Coaxial Slotted Section	Measurement of SWR	500 to 4,000 MC	For Type N Connectors flexible cables	475.00	102
-hp- 805B Coaxial Slotted Section	Same as above	Same as above	For rigid 1/8" RG44/U line	475.00	102
-hp- 806B Coaxial Slotted Section	Same as above (mounts in 809B)	3,000 to 12,000 MC	For Type N Connectors flexible cables	200.00	105
-hp- 809B Universal Probe Carriage	Supports 806B section, also G, J, H, X and P 810 Waveguide Sections		Accepts 442B, 444A probes	160.00	104, 105

△ Rack mounted Instrument available for \$15.00 less.

■ Rack mounted instrument available for \$25.00 less.

Data subject to change without notice. Prices f.o.b. factory.

Copyright 1955 Hewlett-Packard Co.—Printed in U. S. A.—3100 - 2-55 - 50M



Registered Trademark of the Hewlett-Packard Company.



Where to find the *-hp-* instruments you need in this catalog

By instrument type or function:

All *-hp-* instruments shown in this catalog are indexed by type or function on the tables beginning on page at left. (Example—"Vacuum Tube Voltmeters.")

By instrument name or title:

All *-hp-* instruments shown in this catalog are indexed by name or title at the back of the catalog. (Examples—"Amplifier"; "Audio Oscillator.")

By instrument model number:

-hp- instruments are also listed numerically (by model number) at the back of this catalog. (Example—" *-hp-* 410B Vacuum Tube Voltmeter.")

Ordering Information:

Essential ordering information, terms and shipping and repair data are listed on the following page.

Prices:

Prices of major *-hp-* instruments are listed in tables beginning on the page to the left. Prices of certain small components and accessories are listed on pages where such equipment is catalogued.

Warranty:

All *-hp-* instruments are warranted free from defects in materials and workmanship. For details see page 119.

List of *-hp-* engineer-salesmen:

-hp- engineer-salesmen are located in most major manufacturing centers in the United States and Canada. They are listed on the back cover of this catalog. In addition, Hewlett-Packard is represented in many countries overseas. Names and addresses of representatives supplied on request.



Suggestions for Ordering

Order by Model Number . . . Always order by catalog model number and name of instrument desired. For example, "Model 400D Vacuum Tube Voltmeter." Whenever possible mention frequency range or other significant specifications to prevent misunderstanding. Also mention features such as special color, frequency range, non-standard power line voltage, etc., and whether cabinet or rack mounting style is desired.

Most Hewlett-Packard instruments are available in either cabinet or rack mounting. The letter "R" after the model number indicates rack mounting. For example, "400DR." An additional charge is made for most rack mounting style instruments.

Orders should be sent direct to the factory and addressed to Hewlett-Packard Company, 275 Page Mill Road, Palo Alto, California. All orders are subject to final acceptance by the Hewlett-Packard Company.

Shipments . . . Unless specifically requested otherwise, shipments are made by express or by truck, whichever is cheaper and more serviceable to the customer. Small items will be forwarded by parcel post. We do not recommend rail freight shipment. For expedited service, we will gladly ship by air freight, air express (more expensive), or air parcel post upon request.

Terms . . . 30 days net. Unless credit has already been established, shipments will be made c.o.d. All prices are quoted f.o.b. Palo Alto.

Sales Representatives . . . Sales representatives are maintained in principal cities as a service to our customers. Customers are invited to contact the nearest representatives at any time. They will gladly supply technical information, help prepare your order and, if desired, forward order to the factory. Orders should be made out to the Hewlett-Packard Company and are subject to final acceptance by the Company in Palo Alto. Sales representatives and their addresses are shown on the back cover.

Repairs . . . When returning instruments for repairs, recalibration, or any other reason, please contact the Hewlett-Packard Company for shipping instructions. Give model number, type number, and serial number and as much information as possible concerning reason for return.

Repairs are made by the Hewlett-Packard Company at cost of labor and materials plus a small service charge. Customers are invited to make full use of this service to insure maximum benefit from their instruments. In most cases instrument repairs can be made locally at field repair stations maintained by our representatives in Boston, Chicago, Dallas, Detroit, Los Angeles, New York, Philadelphia, Syracuse and Washington, D. C.

Repair Parts . . . When ordering repair parts please describe carefully parts required. Give model number, type number, serial number of the instrument and date of original purchase. Identify parts of the wiring diagram if possible, giving date shown on the circuit wiring diagram.

ABOUT HEWLETT-PACKARD

The Hewlett-Packard Company was founded in 1939 in Palo Alto, California. Here, in a suburban community 30 miles south of San Francisco, next door to Stanford University, Hewlett-Packard is squarely in the heart of the important northern California electronics center.

The first Hewlett-Packard product was a new kind of instrument — a resistance capacity audio oscillator. Hewlett-Packard pioneered the resistance capacity circuit which is now an accepted standard for test oscillator design.

During the past decade and a half, the Company has steadily broadened the instrument line, and now over 250 basic test instruments are manufactured. Among the more important types are audio oscillators, vacuum tube voltmeters, noise and distortion analyzers, signal generators, power meters, broadcast monitors, electronic counters, and a complete coverage array of waveguide and coaxial instrumentation for microwave work. The Company now occupies a modern and well-equipped plant in south Palo Alto, situated on an 8 - acre site and including 140,000 square feet of laboratory, manufacturing and office space. Over 700 men and women are now regularly employed, and approximately 100 field representatives sell and service *-hp-* instruments in the United States, Canada and overseas.

Behind every *-hp-* instrument is a basic philosophy governing equipment design, manufacture, sales and service. This philosophy specifies that there shall be built into each *-hp-* instrument the greatest possible usefulness, accuracy, convenience, dependability and dollar value.

Consistently, Hewlett-Packard has gone to lengths to insure that these standards are met. Every effort has been made to assemble the best engineering staff possible. The Company has sought not only men of skill and experience, but men with vision and daring and a desire to better the best.



*Ultra-modern design features new 44,000 square foot administration and laboratory building at Hewlett-Packard's Palo Alto plant. Like other *-hp-* plant buildings, new structure is sound and light engineered and air conditioned. It contains one of the most modern and complete instrument development laboratories in the world.*

Another cornerstone of the *-hp-* philosophy is insistence on the most up-to-date manufacturing methods. This means not only modern techniques, but modern machinery. Hewlett-Packard's manufacturing departments are equipped with the newest and finest machinery obtainable for the job. Typical of this equipment is a



specialized turret press which punches many sizes of perforations on instrument chassis with a single set-up. Other examples include a heavy duty die casting machine for fast production of dial drive housings and other stationary parts, a fully-equipped machine shop for manufacture of precision mechanical parts, and a complete plastic molding department to fabricate special components which are either unobtainable elsewhere, or can be made more quickly and economically at *-hp-*.

In addition to the different types of commercial machinery, a number of special devices developed by *-hp-* engineers are in daily use. Some of these were developed to meet unusual manufacturing problems; others were "imagineered" to make some special part better, faster, or at lower cost. They include such ingeniously simple units as the Lazy Susans, turntables mounting many resistor boards in a convenient position for assembly. And they include developments which are precision machines in their own right, such as the Kingman machine which stamps out terminal boards in gross quantities.

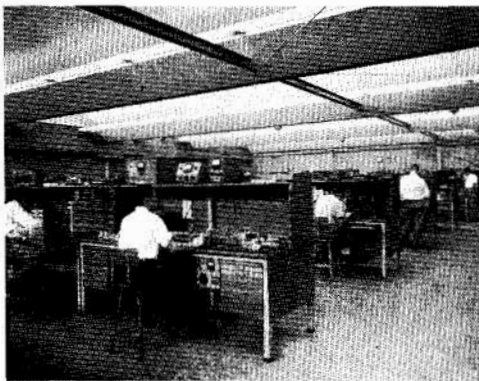

The new -hp- laboratory provides engineers with the most ideal working conditions possible. Note semi-private work benches, generous aisle space, large number of power outlets and individual power controls.

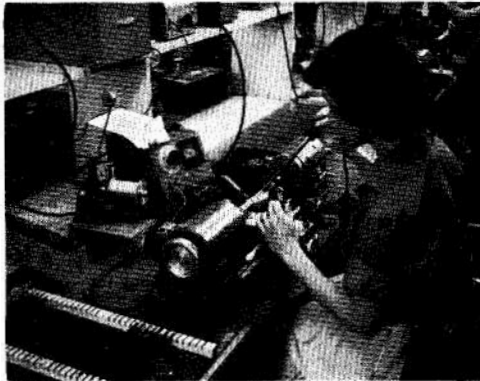

The ingenuity of -hp- engineers has produced many devices to speed and simplify manufacturing, produce better instruments at less cost. This precision lathe for winding resistors handles wire as fine as No. 42.

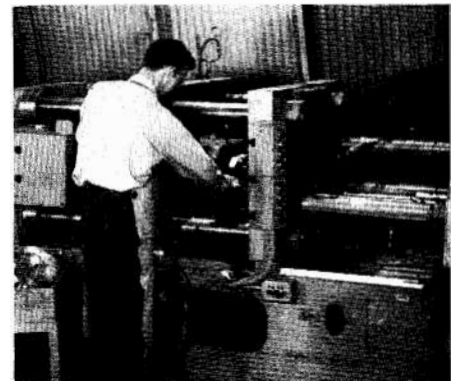

The -hp- plant is equipped with the most modern manufacturing machinery available for the job. Here is a heavy duty die casting machine for production of housings, shields, dials and other cast parts.

The Hewlett-Packard production policy is also somewhat different from that employed elsewhere. Instruments are manufactured in "runs," and actual fabrication is preceded by careful planning to insure that all parts are available and supplied as needed to keep the runs progressing smoothly. As many as ten runs are normally

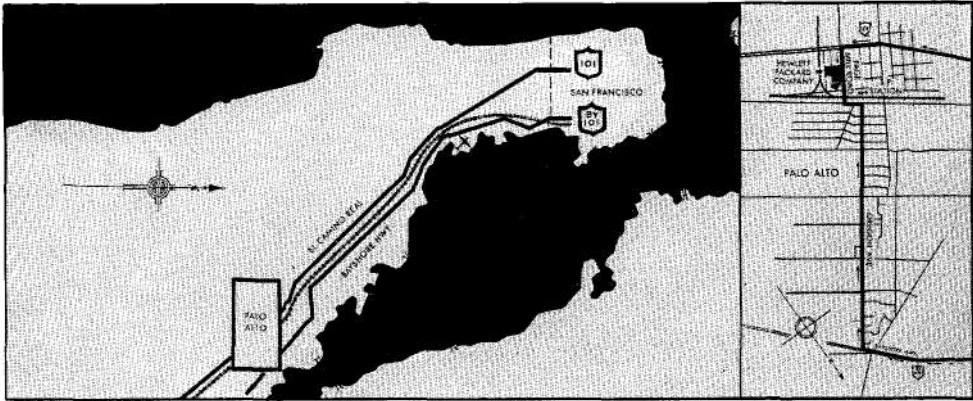

At Palo Alto, home of Stanford University, -hp- is located in the heart of the nation's new electronics center on the San Francisco Peninsula. The -hp- plant may be reached by Southern Pacific commuter train (to South Palo Alto station), by Greyhound bus, or auto on U. S. 101. San Francisco's International Airport is just 30 minutes drive.

in progress simultaneously, yet production schedules are kept flexible to permit meeting special orders or unusual delivery requirements involving substantial numbers of instruments.

In sales and service, Hewlett-Packard makes a particular effort to provide customers with every assistance that will make the use of -hp- instruments more efficient and productive. Factory-trained field engineering representatives provide prompt, on-the-job consultation as well as operating and repair information. These men are constantly supplied with the latest in technical data and measurement technique, and are in almost daily contact with the plant at Palo Alto. For one week of each year, the entire sales organization meets at Palo Alto for an extensive new information and retraining seminar which includes not only theory but actual "field problem" measuring with -hp- instruments and allied equipment. On many additional occasions, -hp- representatives return to the plant for special training or instruction on new instruments and measuring methods.

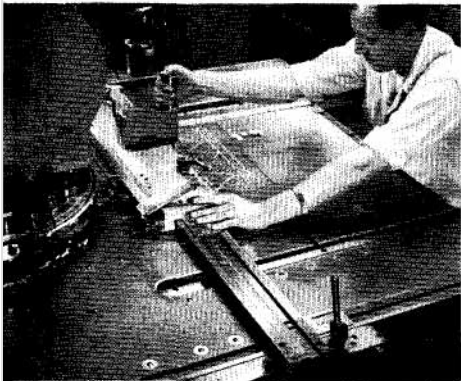

Another unit typical of the modern machinery in daily use at -hp- is this turret press, a precision equipment which punches many sizes of perforations on instrument chassis with a single setup.



The Kingman Machine, above, is another device born and built at -hp- to make possible faster manufacturing at lower cost. Named for the -hp- engineer who "imageered" it, it mass-produces terminal boards.

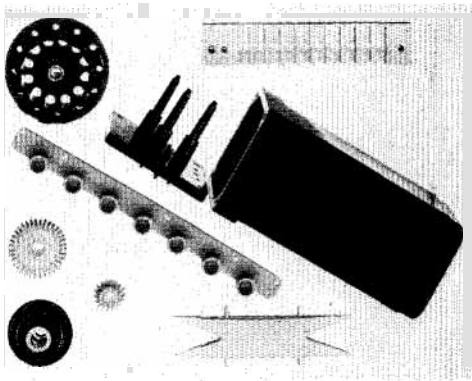

In electronics, special or unusual parts are often hard to find, or prohibitive in cost. To avoid this roadblock to progress, -hp- has its own plastics and molding shop, which turns out knobs, escutcheons, Nylon gears, etc.

An equally significant part of the annual instruction given *-hp-* engineer representatives involves field servicing *-hp-* equipment. This is an important function of the modern *-hp-* service policy described on a preceding page of this catalog.

Old and new. Pictured at right are two *-hp-* audio oscillators—the very first instrument (left) and the brand-new Model 200AB oscillator. The *-hp-* line now includes 11 descendants of the original oscillator which was the first low cost oscillator employing the resistance capacity circuit.

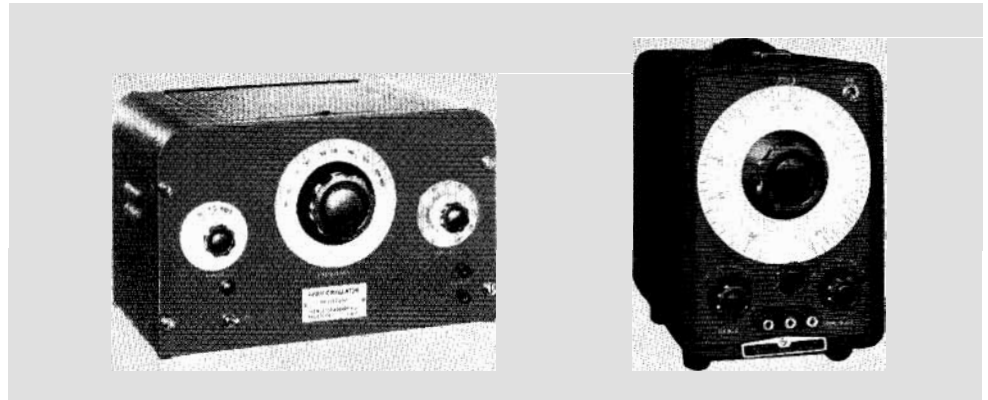

In addition to rigid standards of instrument quality, the best engineering and manufacturing possible, and thorough field engineering service, there is one more aspect of Hewlett-Packard which deserves mention here.

Through the years, there has come into being a definite attitude on the part of *-hp-* people toward the development, manufacture and service of *-hp-* instruments. This attitude is best described as a genuine and pervasive team spirit, a spirit of cooperation coupled with a common desire to excel. *-hp-* people are proud of the quality and the utility of the instruments they design, make and sell. This spirit translates itself continuously into better engineering, better manufacturing, and better service.

The net result to you is good instruments — the best possible, with broadest applicability and the lowest price consistent with quality. Dependable instruments that are not only the best dollar value when purchased, but the best investment for the future. *-hp-* instruments — the standard of the electronic test equipment field.

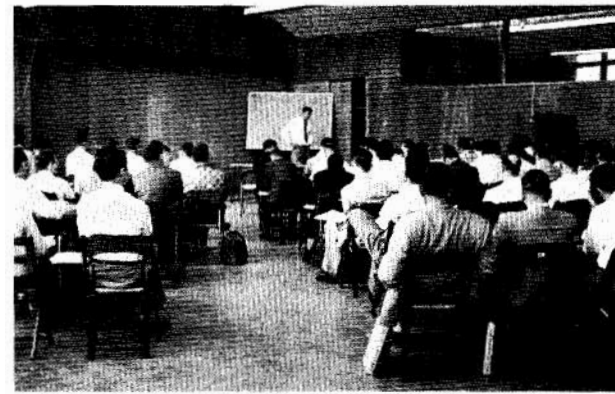

Frequently, members of the world-wide *-hp-* field organization return to Palo Alto to learn the newest developments in instruments and the latest in measuring technique. In addition, all return again to the *-hp-* plant for a week-long annual seminar devoted to the operation and application of *-hp-* instruments.

OSCILLATORS

OSCILLATORS are among the most basic and useful of all electrical and electronic measuring instruments. They provide a convenient source of power or test voltages for almost all measurements, including frequency, gain, impedance, distortion, etc.

There are three primary types of oscillators. These may be defined as (1) Beat-Frequency, (2) Coil Condenser or LC and (3) Resistance Capacity or RC oscillators.

Throughout the years, the RC oscillator has become recognized as the most versatile, practical, dependable and easiest to use of all oscillator types. Hewlett-Packard pioneered and developed the RC oscillator, and is today the leader and largest manufacturer of this superior type of instrument. *-hp-* RC oscillators are highly stable, have wide frequency range and provide operating flexibility which makes them useful for many different kinds of measurements. They are extremely simple to operate and require no tedious re-setting or adjustment during operation. They are lightweight, easily portable, and compact in size to occupy a minimum of bench space. Dependability of operation is assured by clean, simple circuitry and painstaking construction from quality components.

These many advantages may be compared with the low stability, constant need for adjustment, narrow frequency range, inflexibility, large size and considerable weight of other oscillator types.

The *-hp-* series of oscillators includes 13 separate instruments which are essentially resistance-capacity oscillators. Collectively, they operate from 0.01 cps to 10 MC, covering the audio, sub-sonic, ultra-sonic and low rf regions. A number of these instruments are general-purpose types de-

signed to operate over wide frequency ranges and to provide generous output voltages. Others are designed for particular applications.

The circuit of the *-hp-* RC oscillator is shown in Figure 1. It is fundamentally a two-stage amplifier having both negative and positive feedback loops. The positive loop, which includes the frequency-selective network, causes the circuit to oscillate. The resonant frequency is given by the expression $f_0 = \frac{1}{2\pi RC}$. This expression shows that the frequency or tuning span can be made as wide as the capacity variation in a tuning capacitor. Thus 10:1 frequency variations in a single sweep are easily obtained, and a number of

cps and over 1 MC. The low frequency limit is set by the ballast element. The thermal time-constant of the lamp (ballast element) is such that at lower frequencies, lamp resistance tends to change in accordance with the variations in amplitude of the individual cycles of operation. This results in severe distortion of the output waveform. Therefore it is necessary to (1) use a ballast element having relatively greater thermal inertia, or (2) operate the lamp at a point where radiation from the lamp is low.

High Frequency Oscillators

The high frequency limit of the RC oscillator is determined by the plate loading on the second tube of

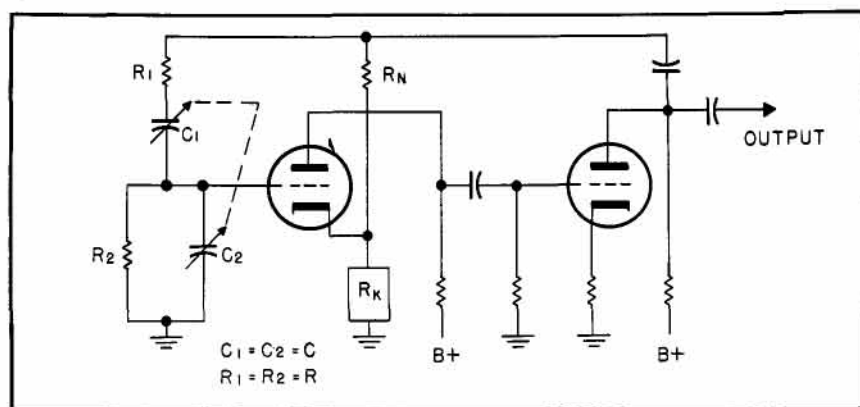

Figure 1. Basic Circuit, *-hp-* RC Oscillator.

bands can be used by changing the pairs of resistances. The negative loop employs a non-linear ballast resistor R_N (usually a lamp), which automatically adjusts its resistance to compensate for variations in output amplitude. This results in very flat frequency response and low distortion over the entire range. It, also, reduces distortion and limits amplitude of oscillations, insuring a constant and stable output over the entire range (Figure 2).

Low Frequency Oscillators

-hp- RC oscillators have been designed to generate frequencies below 1

the oscillator. The impedances of the positive and negative feedback loops are in parallel and the combination is in parallel with the plate feed resistor for the tube. At high frequencies, the combination impedance becomes low and reactive, thereby reducing the gain of the circuit and introducing phase shift. As a result, the distortion increases and the errors in calibration become severe. To cut down the plate loading effect, the combination impedance is made as high as possible. This is achieved partially by reducing the capacity of the tuning condenser, and

partially by raising the gain of the second stage (through use of tubes with higher transconductance values). At higher frequencies the reduction of gain and negative feedback makes the oscillator more susceptible to drifts or variations caused by tube aging and supply voltage changes. As a result it is common practice to operate the circuit from a regulated power supply.

Most *-hp-* oscillators use an output amplifier whose main function is to isolate the oscillating circuit from the "work" circuit. Thus, change in the work circuit does not reflect back to the oscillator and alter its amplitude, frequency or distortion characteristics. However, a unique arrangement is used in the *-hp-* 200CD Wide Range Oscillator where the output is taken from push-pull cathode followers directly to the output transformer. The cathode followers offer a very low impedance source to the load and thus provide effective isolation of the oscillator section.

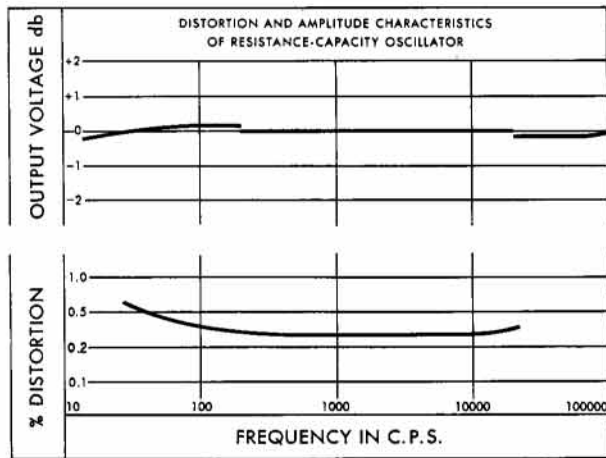

Figure 2. Distortion and Amplitude Characteristics, RC Oscillator.

There are, in general, two types of output circuitry used in *-hp-* oscillators depending upon the desired results. For very low distortion, low frequency, and low power output, RC coupled output is used. For high power or where variable source impedance is required, transformer output is generally employed.

Distortion

Inherently, the RC oscillator is a generator of low distortion voltages. Distortion depends upon the linearity

of the transfer characteristics of the tubes. By a suitable selection of tubes, distortion in *-hp-* oscillators is approximately $\frac{1}{4}\%$. The very low distortion obtained is primarily third harmonic. (Second harmonic distortion is minimized by adjusting the dc voltages on the tube electrodes so that second harmonic distortion generated by one tube of the oscillator is partially cancelled by the other tube's transfer characteristics.) For applications requiring very low distortion, a selective amplifier following the oscillator can be used.

Hum

Hum is defined as alternating currents appearing in the output of an oscillator as a result of power-frequency voltages, currents and fields. Causes of hum are stray electrostatic and magnetic fields, alternating current in tube filaments or heaters, and discrepancies in filtering of power supplies.

As the output voltage of the audio oscillator is reduced, the hum voltage tends to remain constant. At lower output levels this hum voltage becomes quite large relative to the sine wave output voltage. This undesirable condition can be remedied by operating the RC oscillator at or slightly below rated output, and inserting a suitable attenuator between

the oscillator and the equipment driven. The "voltage divider" circuit shown in Figure 4 is satisfac-

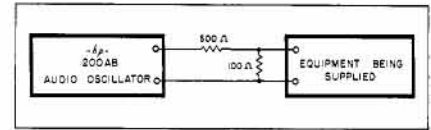

Figure 4. Voltage Divider Circuit.

tory for most applications. Other values of resistance may be used to obtain different voltage divisions but in all cases the sum of the divider resistance must equal the rated load in combination with the input impedance of the equipment under test.

Accuracy

"Overall accuracy" as applied to a variable-frequency oscillator is a general term including factors such as inherent circuit stability, mechanical stability, resettability of the tuning system, readability of the tuning dial, dial calibration, component aging, power supply variations and temperature changes. Some of these factors affect short time stability; others affect long time stability. The accuracy specification of within 2% usually given for RC oscillators includes all of these factors. (Typical long time and short time stability are shown in Figures 5 and 6.)

Description of *-hp-* Oscillators

-hp- 200 series Oscillators (see page 8) are designed for general-purpose applications, such as checking performance of audio amplifiers, broadcast transmitters and similar equipment, checking vibration and stability of mechanical systems, and as voltage sources for bridge measurements, etc. The output is sufficient to modulate signal generators and drive other equipment requiring considerable power. The usefulness of these oscillators

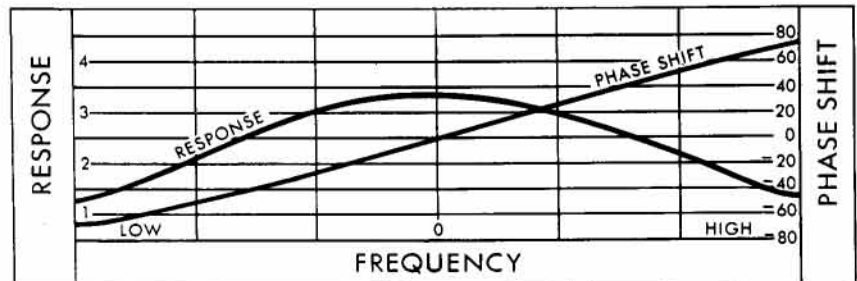

Figure 3. Characteristics of Frequency Determining Network.

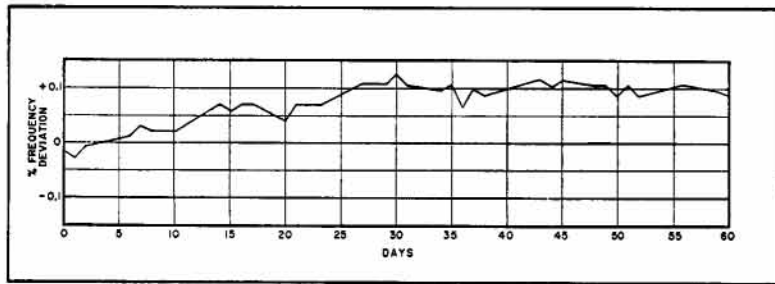

Figure 5. Long-time Stability Curve of circuit using wire-wound resistors and temperature compensation.

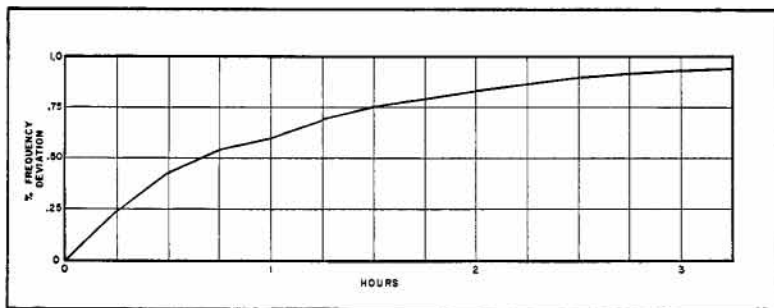

Figure 6. Short-time Stability Curve of RC Oscillator.

is greatly increased by their compact size, light weight and easy portability. *-hp-* 200I is especially suitable for interpolation work and for applications where the frequency of oscillation must be known very accurately.

-hp- 650A (page 14) provides the widest range of any of the general-purpose oscillator group. It operates up to 10 MC and down to 10 cps. It is designed with an output voltage metering system followed by an adjustable attenuator. In these respects, the instrument resembles a signal generator. As a basic laboratory tool, the 650A is popular because of its high degree of flexibility. It can be used to test rf, video, ultra-sonic and audio equipment.

-hp- 202A Low Frequency Function Generator (page 10) incorporates a circuit concept developed by *-hp-* and new to the low frequency oscillator field. The instrument's nominal low frequency limit is 0.01 cps and it can generate sinusoidal, square and triangular output waveforms. The circuit design of this instrument is such that transient conditions caused by range switching or frequency changing are virtually non-existent. This is of considerable convenience

in low frequency work where much time is required for ordinary circuits to stabilize.

-hp- 202B (page 13) is an RC type low frequency oscillator. Its applications include geophysical and medical work, and the study of servo and other low-frequency electrical and mechanical systems.

In audio work there are a number of applications that require test voltages with unusually low distortion. Although *-hp-* RC oscillators are inherently low-distortion generators (with usually less than 1% distortion) *-hp-* 201B Audio Oscillator (page 12) has less than 0.5% distortion at power levels up to 1 watt. Model 201B has an accurate and convenient method of frequency control and is particularly suited to high-fidelity audio work.

-hp- 233A Oscillator (page 16) is widely used in testing carrier-communications equipment. The output system of this instrument is balanced, thus permitting operation directly into balanced lines. Model 233A is a versatile unit and includes many features that make it suitable for testing and adjusting the most advanced types of carrier

equipment. It uses an internal modulator which allows the generated frequency to be modulated by a standard telephone set, thus permitting voice communication between the test point and terminal. It also provides a single-ended output and includes a large tuning dial that gives a high resolution and a convenient arrangement for standardizing calibration.

The latest of *-hp-* RC oscillators is the Model 200T, a precision telemetering test oscillator. It was specifically designed to provide the highest possible frequency stability in a commercial wide range, audio oscillator. It covers the frequency range from 250 cps to 100 KC. The band spread is arranged to provide wide overlap so that the entire RDB spectrum for FM - FM telemetering is covered without splitting a single telemetering channel. The large, 6" diameter dial with many calibration points over 300° of arc, allows precise and swift frequency selection. The instrument has a short warmup cycle of less than an hour; a short term stability of better than 0.02% \pm 0.5% from 10°C to 50°C (reference 20°C); and its power supply voltage stability allows less than \pm 0.1% frequency change for \pm 10% line voltage variation.

Oscillator Output System

-hp- 200AB and 200CD Oscillators have been designed with balanced output transformers. Excellent balance is available with the 200AB throughout its frequency spectrum. Power output is controlled by increasing or decreasing the gain of the power amplifier.

The output level of the 200CD (5 cycles to 600 KC) is controlled by means of a single bridged T attenuator following the transformer. At higher frequency and higher attenuation levels some unbalance is present. If a high degree of balance at these levels is required, *-hp-* AC-60A Line Matching Transformer can be used. Complete specifications and application data on the AC-60 series of line matching transformers is given on page 117.

hp 200 AUDIO OSCILLATORS



Advantages:

- No zero setting. High stability
- Constant output
- Wide frequency range
- Logarithmic scale
- Low distortion
- Compact, light weight

Use Them For:

- Amplifier testing
- Transmitter audio response
- Voltage source for bridge measurements
- Modulating signal generators
- Supersonic voltage source
- Driving mechanical systems
- Synchronizing pulse generators
- Loudspeaker resonance tests

New! Completely Redesigned Highest Quality Throughout!

HEWLETT-PACKARD RC oscillators have long been basic tools for making electrical and electronic measurements of precise accuracy. Now these world-famous test instruments are redesigned to give you the most compact, dependable, accurate and easy-to-use commercial oscillators available.

New *-hp-* 200 series oscillators have highest stability and precisely accurate, easily resettable tuning circuits. Low impedance operating levels together with superior insulation guarantee peak performance throughout years of trouble-free service. New models have wider frequency range and longer dial lengths than previous *-hp-* oscillators and feature an improved, vernier frequency control. Operation is simplified—just three controls are required. Size, too, is different—instruments are more compact, lighter in weight and enclosed in a convenient, smaller aluminum case with carrying handle. They occupy minimum bench space and are easily portable. (Rack mounting available on order.)

The total coverage of just two of the new *-hp-* oscillators is materially greater than that offered by four previous *-hp-* instruments. For example, new Model 200AB, for general audio tests, offers a wider frequency range of 20 cps to 40 KC and a full watt output. New *-hp-* 200CD, for wide range measurements at lower power, provides constant voltage output from 5 cps to 600 KC.

-hp- 200I Interpolation Oscillator

Model 200I is a band-spread oscillator with an extremely accurate tuning system. It is designed for interpolation work, frequency measurement and other applications where the oscillation frequencies must be compared with precise accuracy. Its frequency range is 6 cps to 6 KC. Response is ± 1 db throughout range, and distortion is less than 1% above 10 cps. The instrument delivers 100 mw or 10 volts into a 1,000-ohm load and frequency may be standardized with an accuracy of 1%.



Specifications

-hp- Model	Frequency Range	Bands	Frequency Response	Power Output	Load Impedance	Distortion	Power Consumption	Principal Applications	Weight, Lbs.		Cabinet Size (in.)
									Net	Ship	
200AB	20 cps to 40 KC	4 ranges	± 1 db Ref. 1 KC	1 watt or 24.5 v	600 ohms	Less than 1 %	60 watts	Audio Tests	15	27	7 $\frac{3}{8}$ x11 $\frac{1}{2}$ x12 $\frac{1}{4}$
200CD	5 cps to 600 KC	5 ranges	± 1 db Ref. 1 KC	160 mw - 600 ohms or 20 volts open circuit*		Less than 0.5 %	75 watts	Audio, ultra-sonic, tests	22	36	7 $\frac{3}{8}$ x11 $\frac{1}{2}$ x12 $\frac{1}{4}$
200I	6 cps to 6 KC	6 ranges	± 1 db Ref. 400 cps	100 mw or 10 v	1,000 ohms	Less than 1 % 10 - 6,000 cps	115 watts	Interpolation and frequency measurement	26	39	18 $\frac{3}{4}$ x8 $\frac{5}{8}$ x11 $\frac{3}{4}$
200T	250 cps to 100 KC	5 ranges	± 1 db Ref. 5 KC	160 mw - 600 ohms or 20 volts open circuit*		Less than 0.5 %	100 watts	Telemetry Systems and Interpolation	27	42	18 $\frac{3}{4}$ x8 $\frac{3}{4}$ x11 $\frac{1}{2}$

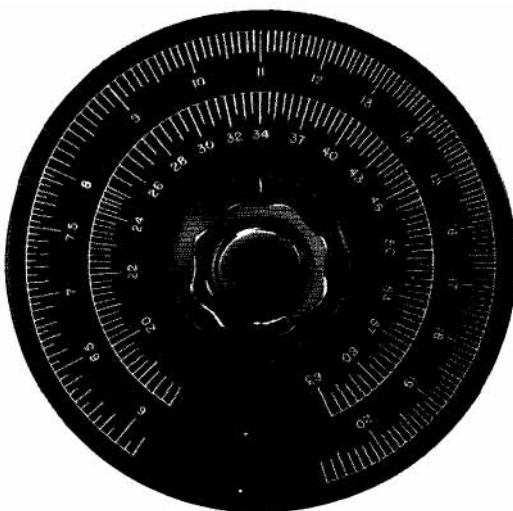

Main tuning dial of -hp- Model 200I, a band-spread oscillator designed for comparison work. The dial is calibrated over approximately 300° with effective scale length of about 90 inches and range of 6 cps to 6 KC. Each instrument is carefully hand-calibrated for maximum accuracy.

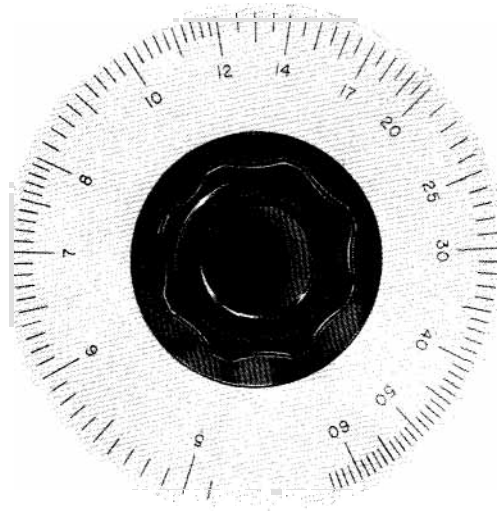

Main tuning dial of -hp- Model 200CD is calibrated over approximately 300° and has an effective scale length of about 60 inches. This precisely calibrated dial with its easy-to-use control contributes much to the accuracy and convenience of the wide-range Model 200CD oscillator.

hp 202A LOW FREQUENCY FUNCTION GENERATOR



Advantages:

- No transient response
- Range 0.008 to 1,200 cps.
- Continuously variable
- High stability
- Flat frequency response
- Distortion less than 1%
- Sine, square, triangular waves
- Versatile, multi-purpose

Use It For:

- Vibration studies
- Servo applications
- Medical research
- Geophysical problems
- Subsonic, audio testing

Transient - Free Voltages Down to 0.008 cps

THE new *hp*- Model 202A Low Frequency Function Generator is a compact, convenient, multi-purpose source of transient-free test voltages at very low frequencies.

The equipment is continuously variable through 5 bands covering all frequencies from 0.008 cps to 1,200 cps. It offers exceptional stability and distortion of less than 1%. Any of three desired wave forms—sine, square or triangular—may be instantly selected on a front panel switch. Output is high—30 volts peak-to-peak—for all three wave forms.

New Circuit Concept

-hp- 202A differs from conventional low-frequency oscillators in that the sine wave is electronically synthesized. A controlled bi-stable circuit generates a rectangular wave. This wave is passed through a special integrator providing a true triangular wave. (See Figure 2A.)

The triangular wave then enters a shaping circuit designed by -hp- exclusively for this equipment. In this circuit, 6 duodiode tubes modify or "shape" the peaks of the wave and provide a true sine wave. (Figure 2B.) This sine wave has a distortion of less than 1%, and the synthesizing circuit provides virtually transient free output even when frequency and operating conditions are rapidly varied. It is not necessary to wait long periods of time for the circuits to stabilize as is the case with conventional low frequency oscillators. The circuit inherently maintains constant amplitude over the entire frequency range.

Special Features

The output system of -hp- 202A is fully floating with respect to ground and may be used to supply a balanced voltage or an output voltage with either output terminal grounded. The equipment will deliver 10 volts RMS into a load of 4,000 ohms or greater. Throughout, internal impedance is only 40 ohms. There are no coupling capacitors in the output system, and a high degree of dc balance is achieved by the special circuitry.

The instrument is ruggedly constructed of quality components; it is unusually simple to operate; and it is adapted to the widest possible variety of low-frequency field or laboratory work. It is available in a cabinet, as illustrated, for relay rack mounting or with end frames for table use.

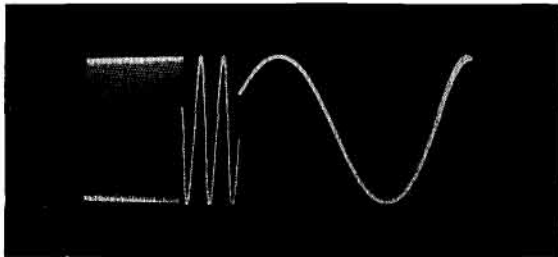

Figure 1. Oscilloscope shows freedom from transients as output frequency is rapidly changed.

Specifications

Frequency Range: 0.008 to 1,200 cps in five decade ranges.

Dial Accuracy: Within 2%.

Frequency Stability: Within 1% including warm-up drift.

Output Waveforms: Sinusoidal, square, and triangular.

Maximum Output Voltage: At least 30 volts peak-to-peak across rated load (4,000 ohms) for all three waveforms.

Internal Impedance: Approximately 40 ohms over the entire range.

Distortion: Less than 1%, 0.008 to 100 cps; 2%, 100 to 1,200 cps.

Output System: Can be operated either balanced or single-ended. Output system is direct-coupled; dc level of output voltage remains stable over long periods of time. DC adjustment available on front panel.

Frequency Response: Constant within 0.2 db.

Hum Level: Less than .01% of maximum output.

Sync Pulse: 10 volts peak negative, less than 5 μ sec duration. Sync pulse occurs at crest of sine and triangular wave output.

Power: 115/230 v \pm 10%, 50/1,000 cps, 175 watts.

Dimensions: Cabinet Mount: 20 $\frac{3}{4}$ " wide, 12 $\frac{1}{2}$ " high, 14 $\frac{3}{4}$ " deep. Rack Mount: 19" wide, 10 $\frac{1}{2}$ " high, 13 $\frac{1}{2}$ " deep. Also can be used with -hp- AC-17 End Frames.

Weight: Net 43 lbs. Shipping 83 lbs. (cabinet mount).

Accessories Available: AC-16A/B Cable Assembly.

Data subject to change without notice.

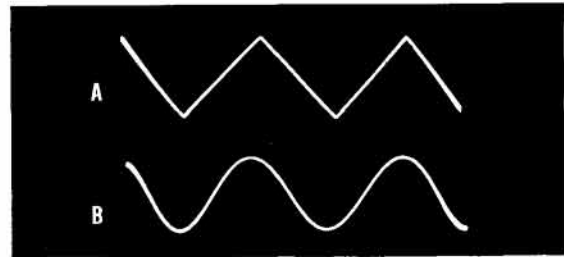

Figure 2. Oscilloscope of (A) triangular wave applied to special -hp- developed shaping circuit and (B) resulting true sine wave.

hp 201B AUDIO OSCILLATOR



Specifications

Frequency Range: 20 cps to 20,000 cps in 3 decade ranges. Calibrated direct in cps, lowest band. 6" illuminated vernier-drive dial with 6:1 ratio.

Stability: Better than $\pm 2\%$ at normal temperatures including warmup. ± 10 v line changes cause negligible variation. Each band may be standardized against an accurate standard to maintain $\pm 1\%$ stability.

Output: 3 watts max. or 42.5 v into 600 ohm load. One terminal at ground potential. 50 v max. no-load voltage.

Frequency Response: ± 1 db over entire range.

Distortion: Less than 0.5%, 50 cps to 20 KC. Less than 1%, 20 cps to 50 cps.

Volume Control: "Amplitude" adjusts oscillator voltage into output amplifier. "Attenuator" attenuates amplifier output. Approx. linear between 0 and 40 db.

Hum Voltage: Less than 0.03% of rated or attenuated output. (Amplitude control at maximum.)

Power: 115/230 v $\pm 10\%$, 50/1,000 cps, 105 watts.

Dimensions: Cabinet Mount: $18\frac{3}{4}$ " wide, $8\frac{3}{4}$ " high, $11\frac{5}{8}$ " deep. Rack Mount: 19" wide, $8\frac{3}{4}$ " high, $10\frac{3}{4}$ " deep.

Weight: Net 28 lbs. Shipping 42 lbs. (cabinet mount).

Accessories Available: AC-16A/B Cable Assembly.

Data subject to change without notice.

Low Distortion, 3 Watts Output, 20 cps to 20 KC.

FOR amplifier testing, transmission line measurements, loud speaker testing, frequency comparison and other high-fidelity audio tests, this *-hp-* oscillator meets all requirements of speed, accuracy, ease of operation and purity of wave form. The built-in stabilized amplifier delivers up to 3 watts of power into a 600-ohm resistance load with distortion less than 0.5% from 50 cps to 20 KC.

The output level of the amplifier is controlled by a potentiometer which adjusts the signal level to its input. An attenuator is provided at the output which adjusts this voltage linearly over a 0-to-40 db range. With the output attenuator in the zero position the internal impedance of the amplifier is approximately 75 ohms. At 10 db or more attenuator setting the internal impedance of the oscillator is virtually 600 ohms.

hp 202B LOW FREQUENCY OSCILLATOR

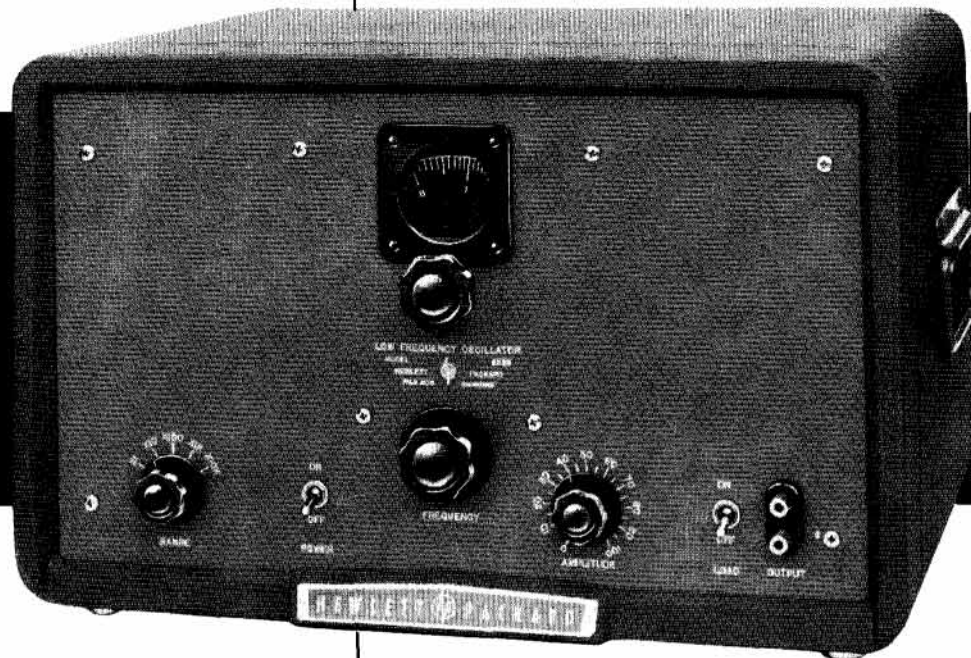

Low Frequency Measurements— 0.5 cps to 50,000 cps

MODEL 202B is a practical, easy-to-use, multi-purpose oscillator for use throughout the low frequency spectrum. It brings to the low frequency field the precise accuracy and high stability associated with audio frequency measurement. It provides excellent wave form throughout its frequency range of 0.5 to 50,000 cps, and has broad applicability for industrial, field or laboratory use.

Uses

The *-hp-* 202B gives maximum measuring speed and accuracy for these important tests: Vibration or stability characteristics of mechanical systems, electrical simulation of mechanical phenomena, electro-cardiograph and electroencephalograph performance, seismograph response, vibration checks of structural components, performance of geophysical prospecting equipment, and general audio measurements.

Specifications

Frequency Range: 0.5 cps to 50 KC in 5 ranges

Range	Frequency
x1	0.5—5 cps
x10	5—50 cps
x100	50—500 cps
x1K	500—5,000 cps
x10K	5,000—50,000 cps

Frequency Dial: 6" diameter. Reads directly in cps for the lowest range. Dial is back of panel, illuminated, and is controlled by direct drive as well as a 6 to 1 vernier.

Calibration Accuracy: $\pm 2\%$.

Frequency Stability: $\pm 2\%$ under normal temperature conditions (including warmup drift). Less than $\pm 1\%$ for power voltage changes of $\pm 10\%$.

Output: 10 volts into a 1,000 ohm resistive load over the entire frequency range. Internal impedance approximately 25 ohms at 10 cps.

Frequency Response: ± 1 db 5 to 50,000 cps.
 ± 2 db 0.5 to 50,000 cps.

Distortion: Less than 1% total distortion, 2 to 50,000 cps.

Hum Voltage: Less than 0.1 % of rated output voltage.

Recovery Time: 50 cps and above approx. 5 sec.
50 cps and below approx. 20 sec.

Power: 115/230 v $\pm 10\%$, 50/1,000 cps, 95 watts.

Dimensions: Cabinet Mount: 20 $\frac{3}{4}$ " wide, 12 $\frac{1}{2}$ " high, 14 $\frac{3}{4}$ " deep. Rack Mount: 19" wide, 10 $\frac{1}{2}$ " high, 13 $\frac{1}{4}$ " deep. Also can be used with *-hp-* AC-17 End Frames.

Weight: Net 43 lbs. Shipping 83 lbs. (cabinet mount).

Accessories Available: AC-16A/B Cable Assembly.

Data subject to change without notice.

hp 650A TEST OSCILLATOR



Advantages:

- No zero set
- Wide frequency range
- No adjustments during operation
- Output voltage attenuator
- Self-contained vacuum tube voltmeter
- High stability
- Ease of operation

Use It For:

- Testing television amplifiers
- Wide-band systems
- Filter transmission characteristics
- Tuned circuit response
- Determining receiver alignment
- Telephone carrier measurements
- Bridge measurements

Fast, Accurate Tests 10 cps to 10 MC

THE *-hp-* Model 650A Oscillator is another of the famous *-hp-* resistance-tuned oscillators. It brings audio frequency speed, accuracy and ease of operation to higher frequency fields. Its wide frequency range, 10 cps to 10 MC, makes it ideal for a wide variety of measurements in audio, supersonic, video and rf bands. It is a wide-band, highly-stable precision instrument which provides output flat within 1 db throughout its frequency range. Its voltage range is .00003 volts to 3 volts. Output impedance is 600 ohms. And, for measurements where low source impedance is desired, a 6 ohm impedance is provided by means of an output voltage divider.

Decade Ranges, Output Voltmeter

Like other *-hp-* resistance tuned oscillators, Model 650A is fast and easy to operate. Six decade frequency ranges provide an effective scale length of 94 inches. The tuning dial is controlled directly, or with a 6 to 1 vernier micro-drive for hair-line adjustment. Frequencies are read through a no-parallax illuminated window.

The output voltage is monitored by a vacuum tube voltmeter which measures the voltage at the input to the attenuator system. The VTVM is calibrated in volts and decibels and reads actual output voltage when the attenuators are set for zero attenuation. For other attenuator settings true output voltage is obtained by subtracting the attenuator reading from the output voltmeter reading. The output attenuator is adjustable in 10 db steps and maximum attenuation is 50 db. The voltage applied to the vacuum tube voltmeter and thus to the output attenuator is set by means of an amplitude control. The attenuated output voltage is correct only when the output terminals are loaded with 600 ohms, resistive.

Output Voltage Divider

Where small test signals or a low source impedance is required, a voltage divider is provided (shown connected to instrument in Figure 1). The divider consists of a cable and terminating connector which may be extended to the actual point of measurement. Two sets of voltages are obtainable from this divider. One voltage is one-hundredth of the normal output voltage from the 650A and is delivered from a source impedance of only 6 ohms. True voltage is obtained at these terminals when they are connected to a load resistance large compared to 6 ohms. The second voltage is the actual output voltage of the Model 650A and is delivered from a source impedance of 300 ohms. Proper voltage is obtained at these terminals when working into a load resistance large compared to 300 ohms.

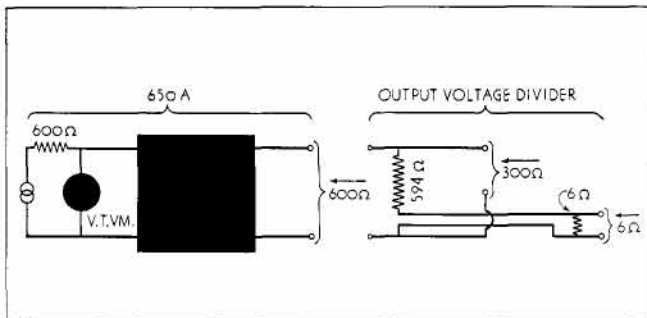

Figure 1

Circuits of the *-hp-* Model 650A have been carefully proportioned and low temperature coefficient components have been employed to assure highest frequency stability. Output voltage will remain constant over long periods of time, despite wide variations in temperature. Distortion over the low frequency bands is kept at a minimum to increase the usefulness of the instrument for audio measurements.

Uses

Employing essentially the same resistance-tuned circuit as *-hp-* audio oscillators (see pages 5, 6, 7 for description of *-hp-* resistance-tuned principle) this wide-band, stable *-hp-* Model 650A is ideally suited for laboratory and production jobs where fast, accurate wide band measurements are required. It is specifically designed for the testing of television amplifiers, audio amplifiers, filter networks, tuned circuits and telephonic and telegraphic carrier equipment. It serves admirably as a power supply for af and rf bridge measurements.

Specifications

Frequency Range: 10 cps to 10 MC. Six bands.

Frequency Calibration: 1 to 10.

Multiplying Factor	Frequency Range
x10 cps	10 to 100 cps
x100 cps	100 to 1000 cps
x1 KC	1000 to 10,000 cps
x10 KC	10 to 100 KC
x100 KC	100 to 1000 KC
x1 MC	1 to 10 MC

Stability: $\pm 2\%$, 10 cps to 100 KC, $\pm 3\%$, 100 KC to 10 MC including warm-up, line voltage variations, and tube changes.

Output: 15 milliwatts or 3 volts into 600 ohm resistive load. Open circuit voltage is at least 6 volts. 600 ohm source impedance. Source impedance of 6 ohms is available when voltage divider is used.

Frequency Response: Flat within ± 1 db, 10 cps to 10 MC into 600-ohm resistive load.

Distortion: Less than 1% from 20 cps to 100 KC. Approximately 5% from 100 KC to 10 MC.

Output Monitor: Vacuum tube voltmeter monitors level at input to attenuator, in volts or db at 600 ohm level. Zero db=1 mw in 600 ohms. Accuracy $\pm 5\%$ of full scale reading.

Output Attenuator: Output level attenuated 50 db in 10 db steps, providing continuously variable output voltage from +12 dbm to -50 dbm, 3 volts to 3 millivolts, or down to 30 microvolts with voltage divider. Accuracy ± 1 db, into resistive load of 600 ohms.

Hum Voltage: Less than 0.5% of maximum attenuated signal level.

Power: 115/230 v $\pm 10\%$, 50/1,000 cps, 165 watts.

Dimensions: Cabinet Mount: 20 $\frac{3}{4}$ " wide, 12 $\frac{1}{2}$ " high, 14 $\frac{5}{8}$ " deep. Rack Mount: 19" wide, 10 $\frac{1}{2}$ " high, 13 $\frac{1}{4}$ " deep. Also can be used with *-hp-* AC-17 End Frames.

Weight: Net 46 lbs. Shipping 88 lbs. (cabinet mount).

Accessories Furnished: 1 65A-16D Output Cable.

Accessories Available: AC-16A/B Cable Assembly.

Data subject to change without notice.



233A CARRIER TEST OSCILLATOR

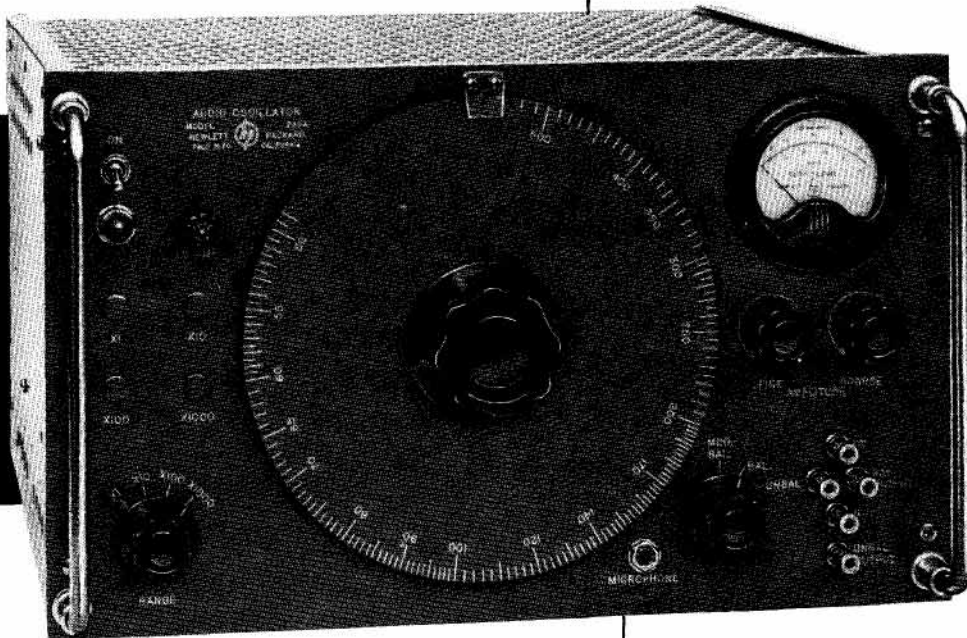

Specifications

- Frequency Range:** 50 cps to 500 KC. 4 decade bands.
- Frequency Dial:** 3:1 vernier control knob. 9" in diameter, 270° arc. Effective scale 85". Effective calibration points approximately 520.
- Frequency Stability:** $\pm 2\%$ under normal room temperatures including initial warmup. $\pm 10\%$ line voltage variations result in negligible change in output frequency.
- Frequency Adjustment:** May be standardized periodically for maximum calibration accuracy. (Approx. 1%.) Each band trimmed by panel screwdriver control.
- Output: No. 1.** 3 watts into 600-ohm balanced load (42.5 volts), 5 KC to 500 KC. Internal impedance 100 ohms, 5 KC to 100 KC, approx. 200 ohms at 500 KC. To match 600 ohms load impedance, approx. 200 ohms resistor pad required in each side of line.
- Output: No. 2.** Approx. 6 volts into a 600-ohm load, 50 cps to 500 KC, one terminal at ground. Internal impedance approx. 6 ohms.
- Frequency Response:** Output No. 1 — ± 1 db, 5 KC to 500 KC. Output No. 2 — ± 1 db, 50 cps to 500 KC.
- Distortion:** Output No. 1—1%, 10 KC to 100 KC at 2 watts; 3%, 10 KC to 100 KC at 3 watts; 4%, 5 KC to 500 KC at 3 watts. Output No. 2—Less than 1% distortion operating into 600-ohm load, 50 cps to 100 KC.
- Modulation:** No. 1 output modulated at voice frequencies from 5 KC to 500 KC. Modulation by means of telephone test set.
- Hum Voltage:** Less than 0.1% to full output.
- Amplitude Control:** Adjusts level on both No. 1 and No. 2 output terminals.
- Voltmeter:** Monitors output No. 1 in volts and db (reference 1 mw in 600 ohms).
- Power:** 115/230 v $\pm 10\%$, 50/1,000 cps, 160 watts.
- Dimensions:** Cabinet Mount: 17 $\frac{3}{8}$ " wide, 10 $\frac{1}{4}$ " high, 15" deep.
- Weight:** Net 39 lbs. Shipping 73 lbs. (cabinet mount).
- Accessories Available:** AC-16A/B Cable Assembly.

Data subject to change without notice.

Fast, Accurate Checking of Carrier Systems Up to 500 KC

THIS new *-hp-* oscillator was designed specifically for checking carrier current systems operating at frequencies up to 500 KC. It provides a high power output of 3 watts into a 600-ohm balanced load, making possible tests over loops 100 to 200 miles long. A second output of 6 volts is available for audio tests (one terminal to ground). The instrument contains a voltmeter which monitors output power. Provisions are made for modulating the carrier so that communications are available on the carrier to facilitate tests.

For maximum readability and accuracy in setting frequency, the instrument has a large, 9" diameter dial calibrated to give an effective scale length of 85" with 520 calibration points. Panel controls adjust the frequency of each band to maintain maximum oscillator accuracy.

AUDIO SIGNAL GENERATORS

ONE of the basic instruments for audio research development, production and maintenance is an audio signal generator.

Hewlett-Packard Audio Signal Generators provide exact voltages across specific impedances at precisely known frequencies. They differ from audio oscillators in their ability to supply accurately known power even at low audio levels. Besides, hum is always maintained at a very low level.

-hp- Audio Signal Generators are useful in making amplifier gain measurements, determining network or transmitter frequency response; as

combination of readings of voltmeter indication and attenuator setting.

-hp- 205AG Audio Signal Generator is a high-power, all-purpose instru-

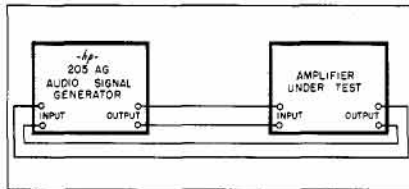

Figure 2. Typical test set-up.

ment. It has a variable frequency between 20 and 20,000 cps at any voltage, 10 microvolts to 150 volts (5 watts), with less than 1% distortion.

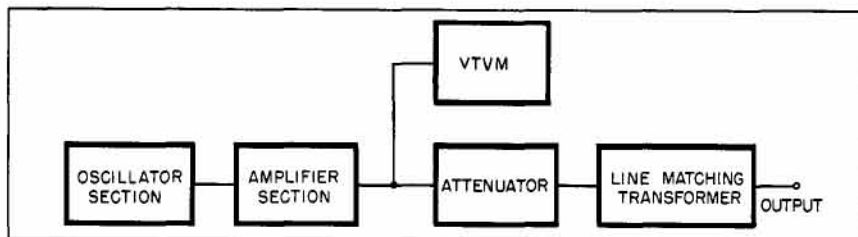

Figure 1. Elements of a signal generator.

signal sources for distortion measurements, in production testing or general laboratory work and in other applications where an accurate, quickly-obtainable signal is desired.

Circuit Description

An Audio Signal Generator comprises an oscillator section, amplifier section, a vacuum tube voltmeter, an attenuator, and a line matching transformer. (See Figure 1.) The output transformer makes several commonly used output impedances available for matching the device under test. This is accomplished by switching taps on the output transformer. The frequency is determined by proper setting of the oscillator. The voltmeter indicates voltage at attenuator input terminals, while attenuator setting controls voltage delivered at output terminals. The output voltage level is determined by a

-hp- 205AG includes an additional vacuum tube voltmeter to measure the output of the device under test. The instrument will determine complete gain and frequency response of an amplifier—no additional equipment is required. (Figure 2.)

-hp- 206A Audio Signal Generator is a precision-built test instrument designed to provide highly accurate test signals from 20 cps to 20 KC. The power output of this unit can be varied in 0.1 db steps, and it will deliver an output level of +15 db above 1 mw into rated load or approximately 10 volts open circuit. Beyond the VTVM, the frequency response of this model is flat within ± 0.2 db from 30 cps to 15 KC. *-hp-* 206A includes a selective amplifier which is automatically tracked with the oscillator. With such an arrangement it is possible to reduce the har-

monic distortion level to less than 0.1%. These features make *-hp-* 206A the finest and most accurate low distortion source for checking distortion in networks, bridge and transmission measurements; for maintenance of high fidelity audio systems, for checking broadcast station performance and for other applications requiring low power, low distortion, accurately known test signals.

Operating Techniques

When making measurements requiring specific steps of output level, a good technique is to set the amplitude control at maximum value and use the attenuator knobs for varying the output level. This procedure insures the highest possible purity of output waveform and greatest attenuation accuracy.

A panel switch is provided to place a 600-ohm impedance across the output transformer of the *-hp-* 205AG when it is to be used with a high impedance load. This serves to match the impedance of the attenuators, so that the output voltmeter together with these attenuators will give the proper indication of output voltage.

With an attenuator setting of zero, the source impedance of *-hp-* 205AG is very low in order to permit maximum power transfer to the load. In applications where a matched source impedance is required one of two procedures should be employed.

- (1) For maximum power output, a resistor should be placed between the 205AG and the load to pad out the generator impedance to line impedance.
- (2) When lower level output is sufficient, use an attenuator setting of 20 db or more for matched source impedance.

In the case of *-hp-* 206A, special design eliminates any variation in source impedance. The impedance is constant at 600 ohms under all conditions.

hp 205AG AUDIO SIGNAL GENERATOR



Advantages:

- No auxiliary equipment needed
- Range—20 to 20,000 cps
- 5 watts output, less than 1% distortion
- No zero setting
- Supplies known voltage
- Output meter calibrated in volts and decibels
- Standardized frequencies instantly available
- Separate input meter for gain measurements
- Wide range of output impedances

Use It For:

- Amplifier gain measurements
- Network frequency response
- Source of voltage for distortion measurements
- Broadcast transmitter audio response
- Loudspeaker response
- General laboratory applications
- Production testing

Six Basic Instruments Combined to Speed Gain Measurements

ALL THE necessary instruments for accurate gain or frequency response measurements have been assembled by *-hp-* engineers in one compact unit. No auxiliary equipment is required.

This Audio Signal Generator brings new speed and ease to testing jobs. Any desired frequency within the range of 20 to 20,000 cps is made available by the resistance-tuned audio oscillator. These frequencies are developed at any desired voltage between 150 volts and 50 microvolts.

To make amplifier or network gain measurements with the *-hp-* Model 205AG Audio Signal Generator, the operator simply connects input and output leads to the binding posts.

Two vacuum tube voltmeters are provided, one to measure input and the second to measure output of the device under test. The input VTVM has a range of -5 dbm to $+48$ dbm, (0 dbm is 1 mw in 600 ohms). The output level is adjusted by means of the step attenuators. The output impedance can be instantly changed by means of a selector switch to the commonly used impedances of 50, 200, 600, and 5,000 ohms, a convenience in matching various types of networks. The *-hp-* 205AG will supply 5 watts output with less than 1% distortion, and thus is useful where sizeable amounts of power are required.

The *-hp-* Model 205AG is well adapted to measuring frequency response and gain or loss of any network. The frequency remains accurate, without the necessity of zero setting. *-hp-* Audio Signal Generators are built for heavy duty and long, hard service.

Specifications

Frequency Range: The frequency coverage is 20 cps to 20,000 cps in three ranges:

X1	20 cps to 200 cps
X10	200 cps to 2,000 cps
X100	2,000 cps to 20,000 cps

Calibration: The dial is calibrated directly in cycles for the lowest range, 20 cps to 200 cps. A switch selects the desired range and indicates the proper multiplying factor. Each range covers approximately 270 degrees on the 6½" main dial.

Stability: Under normal temperature conditions the frequency will drift less than 2% over long periods of time. Each range is provided with an internal adjustment so that 1% accuracy may be maintained if required.

Output: Five watts output will be delivered to a matched resistance load.

Load Impedances: A switch selects transformer taps for use with loads of 50, 200, 600 and 5,000 ohms. The output circuit is balanced and center tapped and any terminal may be grounded. The internal impedance is approximately 1/5 of the load impedance with zero attenuator setting at frequencies up to 5 KC. (Increases above 5 KC.) The internal impedance approaches the load impedance with attenuator settings of 20 db or more.

Frequency Response: The frequency response of the system beyond output meter is flat within ± 1 db at all frequencies and all output levels.

Distortion: The distortion is less than 1% at rated output at all frequencies above 30 cps.

Hum Level: The hum level is 60 db below the output voltage or 90 db below zero level, whichever is the larger.

Output Meter: Output VTVM: calibrated directly in volts at 600 ohms and dbm (0 dbm = 1 mw in 600 ohms.)

Voltage Scale: 0-65 volts, db scale +20 to +37 dbm.

Input Meter: Input VTVM: range from -5 dbm to +48 dbm (0 dbm is 1 mw in 600 ohms). Meter scale is calibrated from -5 to +8 dbm. Multiplier switch

adds from 0 to 40 db in 5 db steps. Input frequency response: ± 0.2 db, 20 to 20,000 cps. Impedance is 5,000 ohms.

Output Attenuator: 110 db in 1 db steps. Consists of 100 db in 10 db steps and 10 db in 1 db steps.

Power: 115/230 v $\pm 10\%$, 50/1,000 cps, 125 watts.

Dimensions: Cabinet Mount: 20¾" wide, 12½" high, 14¾" deep. Rack Mount: 19" wide, 10½" high, 12¾" deep. Also can be used with *-hp-* AC-17 End Frames.

Weight: Net 55 lbs. Shipping 100 lbs. (cabinet mount).

Accessories Available: AC-16A/B Cable Assembly.

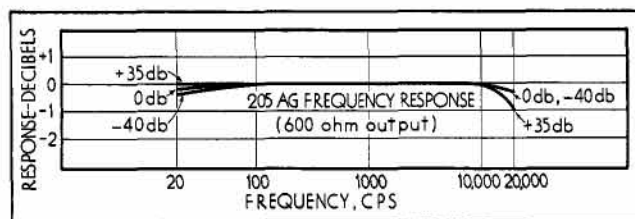

Figure 1. Typical frequency response of *-hp-* 205AG output section. (Response of attenuator and line matching transformer.)

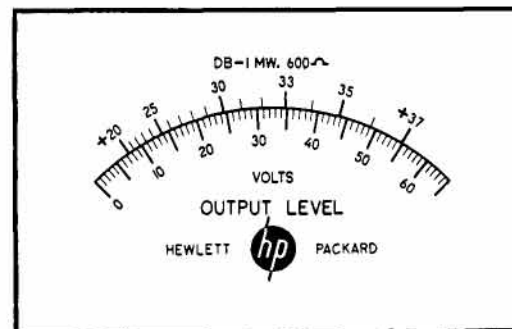
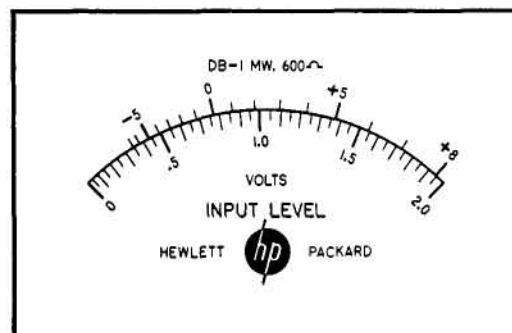

Figure 2. Input and Output Meters, *-hp-* 205AG. Input meter (top) is directly calibrated in dbm based on level in a 600-ohm circuit. Attenuator extends range by 40 db in 5 db steps. Output meter is directly calibrated in volts and dbm for operating into 600-ohm circuits.

Data subject to change without notice.



206A AUDIO SIGNAL GENERATOR



Advantages:

- Continuously variable af voltage
- Accuracy 0.2 db, any level
- High stability
- Harmonic distortion less than 0.1%
- 111 db attenuator, 0.1 db steps

Use It For:

- Audio voltage source
- Checking FM transmitter response and distortion
- Checking broadcast studio performance
- High-quality amplifier testing
- Transmission measurements

Continuously Variable Audio Signals Less Than 0.1% Distortion

THE *-hp-* Model 206A Audio Signal Generator provides a source of continuously variable audio frequency voltage at a total distortion level of less than 0.1%. This unusually low distortion, coupled with simple, straight-forward circuitry, rugged construction and typical *-hp-* ease of operation, makes this new signal generator ideal for use in the maintenance of FM broadcasting units and high fidelity audio systems.

Circuit Description

The circuit arrangement of the Model 206A is shown in the block diagram, Figure 1. The oscillator section is followed by a tuned amplifier, automatically tracked with the oscillator. High selectivity of the amplifier reduces the harmonic voltages generated by the oscillator section. This serves to reduce the percentage of harmonic distortion in the voltage reaching the instrument's output terminals.

The selective amplifier is followed by an output amplifier, a vacuum tube voltmeter, an attenuator and finally an output matching transformer. An electronic voltage regulator supplies plate voltage for the complete circuit.

Frequency Determining Network

The frequency determining network in the instrument's oscillator section is composed of low temperature coefficient elements, so that the instrument will have good stability over long periods of time. The frequency calibration of the instrument is accurate within 1%. Frequencies from 20 cps to 20 KC are continuously available. Three decade frequency ranges provide an effective scale length of 47". Tuning dial is controlled directly or with a 6 to 1 vernier micro drive for hairline adjustments. Dial is read through a no-parallax illuminated window.

The output of the amplifier is measured by a vacuum tube voltmeter. Indications can be read in either volts or dbm to an accuracy of 0.2 db. Following the vacuum tube voltmeter is a 111 db attenuator which allows the power output to be varied in 0.1 db steps.

Output System

The new *-hp-* 206A generator includes an output matching transformer which allows it to be matched to resistive

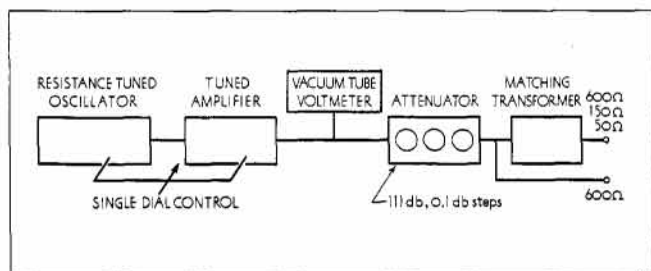

Figure 1

loads of 50, 150 and 600 ohms. This output system is balanced to ground and each winding is center-tapped. The internal impedance matches the load impedance.

A single ended 600 ohm output is provided which bypasses the line-matching transformer. This output connection results in superior distortion and frequency response characteristics.

Uses

This instrument is specifically designed for testing high quality audio circuits. It is suitable for FM transmitter maintenance, studio amplifier and console testing, as a low distortion source for bridge measurements, for use as a transmission measuring set, and for any application requiring a low-distortion, accurately-known audio test signal.

Specifications

Frequency Range: The frequency coverage is 20 cps to 20,000 cps in three ranges:

- X1 20 cps to 200 cps
- X10 200 cps to 2,000 cps
- X100 2,000 cps to 20,000 cps

Calibration: The dial is calibrated directly in cycles for the lowest range, from 20 to 200 cps. Each range covers approximately 270 degrees of the 6" dial. The dial is located behind the panel and is illuminated. A six to one rim drive enables the equipment to be easily and quickly set to any desired frequency.

Stability: The frequency is calibrated to within better than 1% when the instrument leaves the factory. The circuit elements in the frequency determining network have low temperature coefficients and good stability so that better than 2% accuracy will be maintained over long periods of time.

Output: The equipment will deliver an output level of +15 db above 1 mw into impedances of 50, 150 and 600 ohms. Approximately 10 volts are available into an open circuit.

Output Impedances: The generator has a matched internal impedance and the selection of output impedances includes 50, 150 and 600 ohms center-tapped and balanced and 600 ohms single ended.

Frequency Response: The frequency response of the system beyond the output meter is better than 0.2 db at all levels, 30 cps to 15 KC.

Distortion: The total harmonic distortion in the output voltage is less than 0.1% at frequencies above 50 cps and less than 0.25% from 20 cps to 50 cps.

Hum Level: The residual hum and noise in the output signal is at least 70 db below the output signal or more than 100 db below zero level, whichever is the larger.

Output Meter: The output voltage is measured ahead of the attenuators by a 4" square meter calibrated in dbm and also in volts. The meter has a scale which can be read to at least 0.2 db at all points above a 50% scale reading. (Zero dbm equals 1 mw in 600 ohms.)

Output Attenuators: Output attenuators provide a range of 111 db in 0.1 db steps. The accuracy of the attenuator is ± 0.5 db at attenuations up to 80 db and ± 1 db above 80 db.

Power: 115/230 v $\pm 10\%$, 50/1,000 cps, 145 watts.

Dimensions: Cabinet Mount: 20 $\frac{3}{4}$ " wide, 12 $\frac{1}{2}$ " high, 14 $\frac{3}{4}$ " deep. Rack Mount: 19" wide, 10 $\frac{1}{2}$ " high, 13 $\frac{1}{2}$ " deep. Also can be used with *-hp-* AC-17 End Frames.

Weight: Net 56 lbs. Shipping 100 lbs. (cabinet mount).

Accessories Furnished: 1 M-72 Power Cord.

Accessories Available: AC-16A/B Cable Assembly.

Data subject to change without notice.

hp 212A PULSE GENERATOR

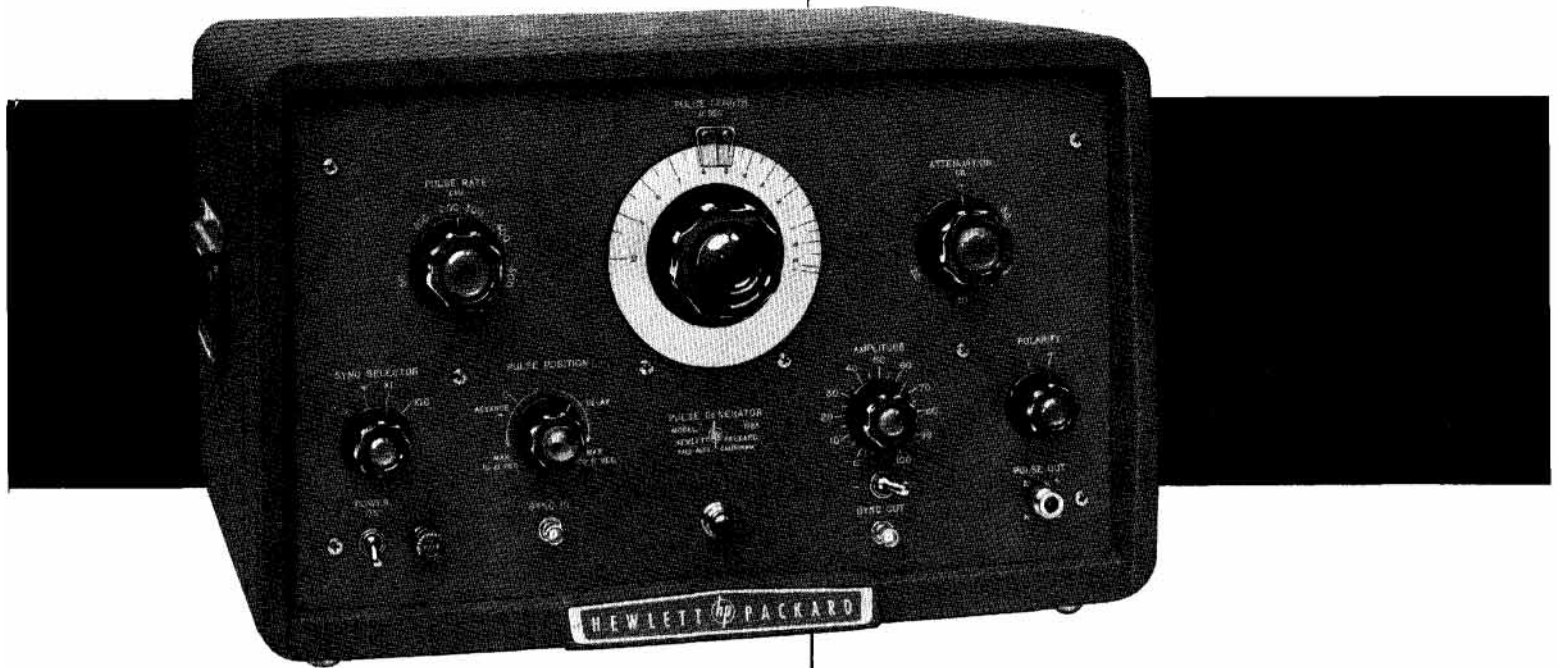

Advantages:

- Broadest usefulness
- 50 watt peak pulses
- 0.02 μ sec rise and decay
- Positive or negative pulses
- Complete synchronization
- Freedom from jitter

Uses:

- Radar, TV and nuclear work
- Testing rf amplifiers, filters, band pass circuits, oscilloscopes
- Noise generator
- Checking peak measuring equipment
- Pulse-modulating uhf signal generators

Basic Test Instrument for Radar, TV and Other "Fast" Circuits

THE MODEL 212A Pulse Generator is designed for versatility and time-saving convenience. It offers positive or negative pulses, and may be synchronized to other equipment through built-in delay and advance sync out circuits. It offers continuously variable pulses from 0.07 to 10 microseconds. It has a direct-reading pulse length control, and 50 watts of pulse power. It offers high quality pulses with very fast rise and decay time, "flat" top, and minimum overshoot. (See Figures 1 and 2.) The instrument permits accurate pulses to be delivered to the end of a long transmission line. If line is correctly terminated pulse shape is independent of line length, sync conditions, input voltage or output attenuator setting.

In addition to radar, TV and nuclear work the generator is useful for testing response of rf amplifiers, filters, band pass circuits, oscilloscopes; as a noise generator, to check peak measuring equipment, modulate rf carriers, or pulse modulate uhf signal generators.

Double Pulses

Double pulses, useful for checking resolution time of pulse counters, can be obtained by connecting a stub line across the output of the generator. (See Figure 3.) In this application, pulse spacing is determined by the length of the stub line. When multiple pulses are required (for checking pulse position modulated equipment, as an example), -hp- 212A Pulse Generators can be connected in parallel. Pulse shape is well maintained, and a generous output voltage is available even when a number of units are paralleled to make a pulse train. In this application, the position, lengths and heights of the various pulses are fully variable. (For further information see -hp- Journal, Volume 5, Number 10.)

Output System

In the 212A, the major output pulse is applied to the output terminals through a step attenuator providing 50



Figure 1. 0.07 microsecond pulse delivered by -hp- Model 212A.

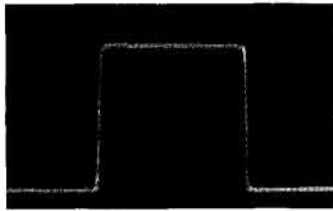

Figure 2. 1.0 microsecond pulse delivered by -hp- Model 212A.

db of attenuation in 10 db steps. Use of this attenuation does not cause deterioration of pulse shapes, even when small pulse voltages are desired. A continuously-variable amplitude control is also provided for making fine adjustments of output voltage. Maximum amplitude of the major output pulse is at least 50 volts into a 50 ohm load.

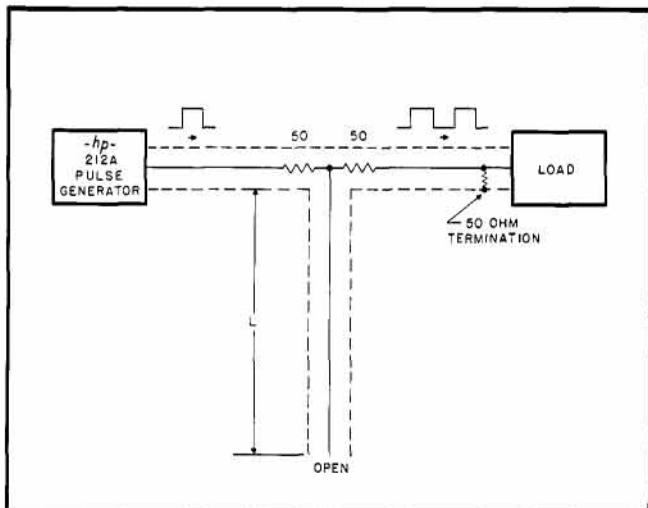

Figure 3. Circuit for generating double pulses.

Specifications

Pulse Length: At least 0.07 to 10 microseconds, continuously variable.

Pulse Amplitude: At least 50 volts peak into 50 ohm load (50 watts peak).

Pulse Polarity: Positive or Negative.

Amplitude Control: (a) 50 db attenuator, variable in 10 db steps.

(b) Continuously variable control with range of at least 10 db.

Pulse Shape: (a) Rise and decay time approximately 0.02 microseconds (10% to 90%).

(b) Crest variation less than $\pm 5\%$ of average peak amplitude.

Jitter: Less than 0.01 microseconds.

Internal Impedance: 50 ohms or less on either pulse polarity.

Repetition Rate: (a) Internal synchronization, 50 to 5,000 pps.

(b) External synchronization, 0 to 5,000 pps.

Sync In: Positive or negative, 5 volts peak minimum.

Sync Out: (a) 40 volts positive or 25 volts negative into 2,000 ohm load.

(b) Duration, approximately 1 microsecond at half voltage points.

(c) Rise time, approximately 0.25 microseconds.

Pulse Position: (a) Delay, 0 to 100 microseconds after sync out pulse.

(b) Advance, 0 to 10 microseconds before sync out pulse.

Connectors: (a) Main pulse, Type N.

(b) Sync in, sync out, Type BNC.

Power: 115/230 v $\pm 10\%$, 50/60 cps, 325 watts.

Dimensions: Cabinet Mount, 20 $\frac{3}{4}$ " wide, 12 $\frac{1}{2}$ " high, 14 $\frac{3}{4}$ " deep. Rack Mount: 19" wide, 10 $\frac{1}{2}$ " high, 13 $\frac{1}{4}$ " deep. Also can be used with -hp- AC-17 End Frames.

Weight: Net 57 lbs. Shipping 96 lbs. (cabinet mount).

Accessories Available: AC-16K Video Cable Assembly; AC-16F rf Cable Assembly.

Data subject to change without notice.

hp 211A SQUARE WAVE GENERATOR



Specifications

Frequency Range: 1 cps to 1 MC, continuous coverage.

Low Impedance Output: 7.0 v peak-to-peak across 75 ohm internal impedance. Rise time less than 0.02 μ sec. BNC connector.

High Impedance Output: 55 v peak-to-peak across 600 ohm internal impedance. Rise time less than 0.1 μ sec. Dual banana jacks— $\frac{3}{4}$ " centers.

Amplitude Control: Low Impedance Output—potentiometer and 60 db attenuator, variable in 20 db steps. High Impedance Output—potentiometer.

Frequency Control: Dial calibrated "1 to 10" and decade multiplier switch. Six bands.

Symmetry Control: Allows exact square-wave balance.

Sync Input: Positive-going pulse or sine wave signal, minimum amplitude 5 volts peak. BNC connector.

Power: 115/230 v $\pm 10\%$, 50/60 cps, 130 watts.

Dimensions: Cabinet: $9\frac{3}{4}$ " wide, $13\frac{7}{8}$ " high, $13\frac{3}{8}$ " deep.

Weight: Net 27 lbs. Shipping 49 lbs. (cabinet mount).

Accessories Available: AC-16A/B Cable Assembly. AC-16D Cable Assembly.

Data subject to change without notice.

New! For Audio, Video Testing 1 cps to 1 MC

THE NEW Model 211A Square Wave Generator is a versatile, wide range instrument particularly designed for testing video and audio amplifier performance, or checking oscilloscope operation. It provides complete coverage of all frequencies from 1 cps to 1 MC, and has a rise time of 0.02 microseconds. There are two separate outputs—a 7 volt peak-to-peak 75 ohm impedance circuit for television measurement, and a 55 volt peak-to-peak 600 ohm output for high level work. Full amplitude variation is available on either output. The generator may be operated free-running or externally synchronized with either a positive-going pulse or a sine wave signal of 3 volts minimum amplitude.

Uses

Model 211A is ideal for testing amplifiers and networks and modulating signal generators. It will measure time constants, check cathode ray sweep circuits, and generate harmonics for frequency multiplication. It offers a simple means of controlling an electronic switcher. The generator is also a convenient instrument for indicating phase shift, frequency response or transient effects.

WAVE AND DISTORTION ANALYZERS



FAST, convenient measurement of harmonic distortion is of great value not only in the laboratory, but in the manufacturing and testing of electronic, electrical and mechanical equipment.

Distortion in a network may be defined as the presence of harmonics along with the fundamental. This harmonic distortion is the result of non-linear transfer characteristics of a network, and may be expressed:

$$\% \text{ distortion} = \frac{(A_2^2 + A_3^2 + A_4^2 + \dots)^{1/2}}{A_1} \times 100$$

(In this expression A_1 is the amplitude of the fundamental, A_2 is the second harmonic, A_3 is the third harmonic, etc.)

Distortion Measuring Methods

Two procedures are commonly followed in determining distortion. One of these is the "fundamental" method. In this method, a single pure frequency is fed to a device and each frequency appearing at the output is measured with a frequency-selective voltmeter or a wave analyzer. The measured values are substituted in the expression given above and percent distortion may be calculated.

A second method is known as "total" distortion measuring. A single pure frequency is again fed to the device. Here the amplitude of the output voltage containing harmonics is first measured. Then the fundamental frequency is filtered out and the rms value of the combined harmonics is measured. The ratio of the two

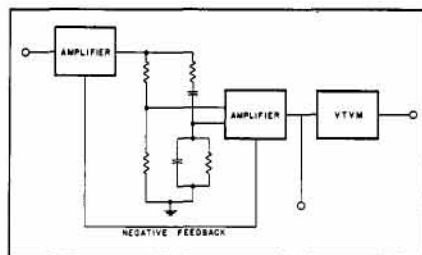

Figure 1

Block diagram of *-hp-* 330B Distortion Analyzer.

values expressed in percent is the distortion in the circuit.

-hp- Wave Analyzer

For measuring distortion by the "fundamental" method, *-hp-* Model 300A Harmonic Wave Analyzer (page 26) is well suited. This instrument is of the selective-voltmeter type, and is ideal for measuring individual components of a wave. For example, the exact value of second harmonic voltage can be measured in the presence of hum and other extraneous voltages. Applications of this versatile equipment include determination of harmonic components in ac machinery and power systems, study of induced voltage in telephone lines, analysis of hum and noise in electronic systems. The instrument also makes possible convenient determination of intermodulation or cross modulation generated by simultaneous transmission of two frequencies in an audio system. And, it provides a simple means of measuring demodulation of a modulated wave applied through an audio system.

-hp- Distortion Analyzers

-hp- 330 series Distortion Analyzers are basically selective amplifiers whose

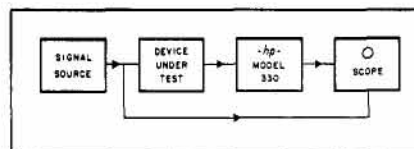

Figure 2

Recommended set-up for distortion measurement using *-hp-* 330 Analyzers.

frequency of rejection is tunable. (See Figure 1.) They are designed for measuring distortion by the "total" method between 20 and 20,000 cps. These instruments are extremely simple to use, and are particularly useful in measuring total audio distortion or hum and noise level in audio amplifiers. They are also convenient for measuring voltage levels, power out-

put, amplifier gain; and may be used as high-gain, wide-band stabilized amplifiers. The 330D includes a linear rf detector for determining distortion in modulated AM and FM broadcast carriers.

A typical set-up utilizing *-hp-* 330 series analyzers for measuring by the "total" distortion method is shown in Figure 2. The combination of distortion analyzer and oscilloscope is an

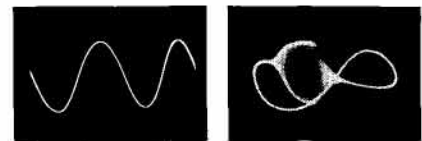

Figure 3

Oscillograms showing (a) sine wave with 1.5% distortion, (b) second harmonic distortion with superimposed transient oscillations.

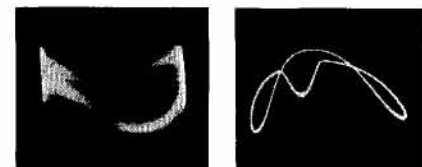

Figure 4

Oscillogram showing distortion in amplifiers when (a) distortion level is of same order of magnitude as hum, (b) amplifier is driven at point of overload; notch in pattern is caused by small grid current.

ideal arrangement and provides a great deal of information. With this set-up, transient oscillations caused by saturation of iron in the circuit can be easily detected, as can continuous oscillations caused by unfavorable gain-shift characteristics. Such oscillations indicate an unstable system and are often unstable themselves. However, they are frequently non-detectable unless an oscilloscope is used.

The analyzer-oscilloscope combination is also useful for determining the nature of distortion, the presence of excessive noise and hum; or for detecting distortion caused by grid current on driving peaks. (Figures 3 and 4.)

hp 300A HARMONIC WAVE ANALYZER

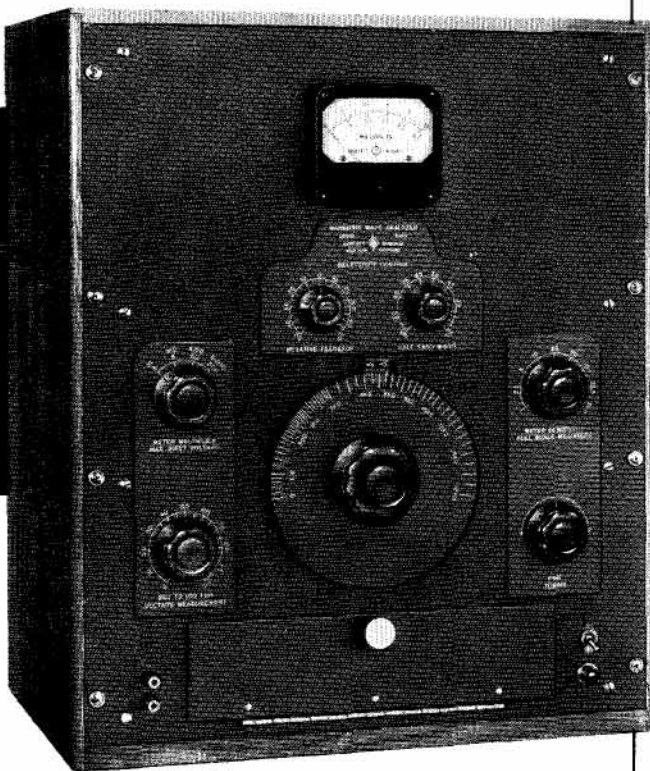

Advantages:

- Direct reading
- Simplified operation
- Variable selectivity
- Wide voltage range
- Linear meter scale

Use It To Analyze:

- Noise characteristics
- Broadcast amplifier characteristics
- Modulating amplifier distortion
- Recording devices
- Film sound track distortion
- Recording distortion
- Hum
- Network characteristics

Variable Selectivity Provides Rapid, Accurate Wave Analysis

THIS -hp- Model 300A Harmonic Wave Analyzer is a selective voltmeter designed to measure the individual components of complex waves. The selectivity can be varied by means of a unique selective amplifier. Where the harmonics are close together the high selectivity easily separates the wave components. Yet, where the components are spaced far apart, the selectivity may be widened to increase the speed of operation without sacrificing essential accuracy. This feature is also valuable where it is necessary to measure distortion of waves containing a small amount of frequency modulation, such as in sound tracks, and may be used conveniently to integrate a small portion of the audio spectrum in noise measurements and the like. Maximum selectivity is sufficient to separate harmonic components spaced 30 cycles apart. (See Figure 1.)

Direct Reading

The *-hp-* Model 300A Harmonic Wave Analyzer covers the audio spectrum from 30 cps to 16,000 cps. The wide voltage range covers the values encountered in nearly every application. Full scale voltmeter readings may be obtained with inputs of .001 to 500 volts so that the instrument may be used with equal success with low output transducers and high power modulating amplifiers. Other features which make it unexcelled for both laboratory and production testing are the linear meter scales fully protected against overloads, and the built-in calibrating system to standardize voltage measurements.

Theory

The circuit of the Model 300A consists of a variable local oscillator, a balanced modulator, a selective amplifier, and an indicating meter. The variable local oscillator modulates the unknown frequency to produce a constant difference frequency. This difference frequency is applied to the selective amplifier, the output of which is then proportional to the magnitude of the unknown voltage. A meter in the output of the selective amplifier indicates the magnitude of the voltage.

The local oscillator is of the resistance-tuned type, providing a very stable, accurate voltage. A balanced modulator is used to eliminate the local oscillator frequency and to keep cross-modulation products very low. The selective amplifier consists of four tuned circuits in which the effective Q is controlled by positive feedback. Negative feedback is also used to stabilize the amplifier.

This amplifier has the unique characteristic that its selectivity may be varied over a wide range without appreciably affecting the gain of the amplifier.

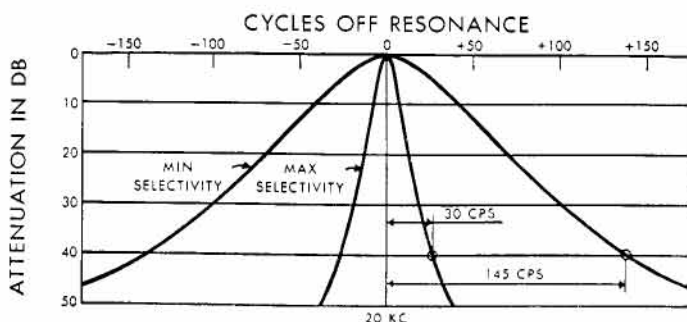

Figure 1

Uses

The Model 300A is well adapted to the measurement of the harmonic distortion in audio frequency equipment of all kinds, broadcast receivers, transmitters; to determine the harmonic components in ac machinery and power systems; to the study of induced voltages on telephone lines; to measurement of hum components in rectifier circuits.

Other uses include the study of noise by integrating por-

tions of the spectrum with the selectivity control adjusted for a wide pass band and the checking of wave filter characteristics with maximum selectivity.

The *-hp-* 300A is also useful as a device to measure the amount of cross- or inter-modulation products generated by the simultaneous transmission of two frequencies by an audio system or to measure demodulation of a modulated wave applied through an audio system.

Specifications

Frequency Range: 30 to 16,000 cps.

Frequency Calibration: Within $\pm 3\%$.

Voltage Range: 0.1 millivolt to 500 volts, with full-scale readings of:

500 volts	5 volts	50 millivolts
250	2.5	25
100	1	10
50	0.5	5
25	0.25	2.5
10	0.1	1

Ranges provided by an input switch which selects maximum voltage values of 500, 50, 5 or 0.5 volts, and a meter multiplier to select finer divisions.

Voltage Accuracy: $\pm 5\%$ of full-scale value. Adjacent harmonics must be spaced so as to be suppressed by the selectivity of the instrument.

Residual Modulation Products: Suppressed at least 65 db.

Hum Voltage: At least 75 db below 0.5, 5, 50, or 500 volts, depending on input range selected.

Selectivity: Variable from 30 to 145 cps at the 40 db points (see curve).

Input Impedance: 200,000 ohms. Potentiometer included for setting external voltage reference (set to maximum for voltage measurements).

Power: 115/230 v $\pm 10\%$, 50/60 cps, 105 watts.

Dimensions: Cabinet Mount: 23" wide, 24" high, 14" deep. Rack Mount: 19" wide, 22 $\frac{3}{4}$ " high, 12" deep.

Weight: Net 80 lbs. Shipping 150 lbs. (cabinet mount).

Accessories Available: AC-16A/B Cable Assembly. AC-60B Transformer (for bridging input).

Data subject to change without notice.

hp 330B DISTORTION ANALYZER



Advantages:

- Blankets audio spectrum
- Measures noise as small as 100 μ V
- High sensitivity, high stability
- Measures distortion as low as 0.1%
- Wide-band 20 db gain amplifier
- Oscilloscope terminals, built-in VTVM
- High-gain, wide-band amplification

Use It To Determine:

- Total audio distortion
- Voltage level, power output, gain
- Total distortion of AM rf carrier
- Noise and hum level directly
- Audio signal frequency

Accurate Distortion Readings 20 cps to 20,000 cps

THE *-hp-* Model 330B Distortion Analyzer will give you quick, accurate measurements of distortions as low as 0.1% at any frequency from 20 cps to 20,000 cps. It will make noise measurements of voltages as small as 100 microvolts. The analyzer has high sensitivity and high stability. Its circuit includes a 20 db amplifier, oscilloscope terminals and a precision vacuum tube voltmeter which is usable separately.

These many features give the instrument exceptional usefulness for all kinds of audio measurements in recording and motion picture facilities, broadcast studios, research laboratories and in maintaining quality of audio production.

Circuit Description

Basically, *-hp-* 330B Distortion Analyzer consists of a frequency-selective amplifier, a regulated power supply and a vacuum tube voltmeter. (See Figure 1, page 25.)

The 20 db amplifier operates in conjunction with the *-hp-* resistance-tuned circuit to provide infinite attenuation

at one frequency while allowing all other frequencies to be passed at the amplifier's normal gain. (See Figure 1.) Negative feedback is employed in the amplifier to minimize distortion, to give a uniform response over a wide range of frequencies and to provide high stability. Frequency response is flat within $\pm 3\%$ from 10 cps to 100,000 cps; thus even the 5th harmonic of 20,000 cps is passed by the amplifier without appreciable attenuation.

The voltmeter section of the equipment consists of a two-stage, high-gain amplifier, a rectifier and an indicating meter. A large amount of negative feedback is again employed to insure stability and uniform response from 10 cps to 100,000 cps. The voltmeter—which may be used as a separate instrument—responds proportionately to the average value of the applied voltage wave and is calibrated in rms values of a sine wave.

FM, AM-FM Distortion Analyzers

Model 330C Distortion Analyzer

For FM broadcasters, the *-hp-* 330C Distortion Analyzer is offered. It is identical in all respects with *-hp-* 330B, except that the indicating meter movement is provided with VU ballistic characteristics to meet F.C.C. requirements for FM broadcasting. Like the 330B, Model 330C provides infinite attenuation at any one frequency and makes possible total audio distortion measurements at any frequency from 20 to 20,000 cps.

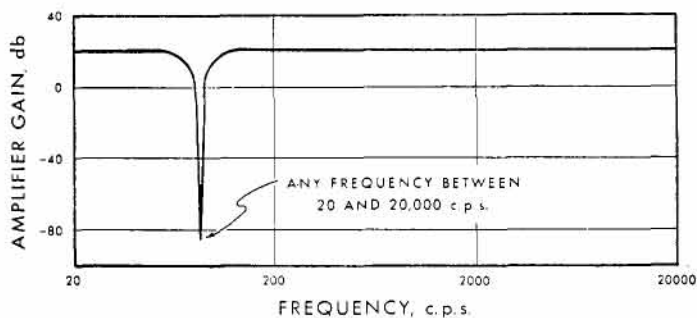

Figure 1

Model 330D Distortion Analyzer

For radio stations and other installations where both AM and FM measurements are required. Includes an AM rf detector with a diode rectifier operating in conjunction with a resonant circuit tuned to the carrier frequency under measurement. Detector covers a range of 500 KC to 60 MC and is varied by tuning condenser and range switch which selects one of five bands. (Detector may be switched out of circuit when audio frequencies are used.) Model 330D also includes the special VU meter employed in Model 330C. Other specifications are similar to Model 330B.

Specifications

Distortion Measurement Range: Any fundamental frequency, 20 cps to 20 KC.

Frequency Calibration Accuracy: $\pm 2\%$ entire range.

Elimination Characteristics: Fundamental frequency reduced by more than 99.9% (60 db). Second harmonic attenuation less than 17% (1.5 db) for fundamental frequencies 20 cps to 5 KC; less than 32% (3 db) for fundamental frequencies 5 KC to 20 KC.

Accuracy: Residual frequencies are measured to within $\pm 3\%$ of full scale value for distortion levels as low as 0.5%. Meter indication proportional to average value of residual components. Distortion introduced by instrument less than 0.1%.

Sensitivity: Distortion levels of 0.3% are measured full scale. Levels of 0.1% readable with good accuracy.

Distortion Meter Input Impedance: Approximately 200,000 ohms, 40 μmf shunt.

Input Level for Distortion Measurements: At least 1 volt rms.

Voltmeter Sensitivity: Full scale sensitivities of 0.03, 0.10, 0.30, 1.00, 3.00, 10.0, 30.0, 100 and 300 volts. Nine ranges spaced exactly 10 db. Db scale: -12 db to $+2$ db, calibrated on zero level = 1 milliwatt in 600 ohms.

Voltmeter Frequency Range: Model 330B, 10 cps to 100 KC; Models 330C and 330D, 10 cps to 60 KC.

Voltmeter Accuracy: For line voltages of nominal value $\pm 10\%$ (104 volts to 126 volts), Model 330B within $\pm 3\%$, 10 cps to 100 KC; Models 330C and 330D within $\pm 3\%$, 10 cps to 20 KC and $\pm 6\%$, 10 cps to 60 KC.

Voltmeter Input Impedance: Approximately one megohm, 37 μmf shunt.

Noise Measurement: Full scale reading of 300 microvolts. Noise measuring frequency range, 10 cps to 20 KC. Satisfactory readings can be made to -75 dbm.

Oscilloscope Terminals: Maximum gain from AF input to oscilloscope terminals is 75 db with full-scale meter deflection.

Meter Movement: Models 330C and 330D: VU ballistic characteristics to meet F.C.C. requirements for AM, FM and TV broadcasting.

AM Detector: Model 330D: linear rf detector rectifies the transmitter carrier. Input circuit tunable from 500 KC to 60 MC in 5 bands. Detector distortion is negligible.

Power: 115/230 v $\pm 10\%$, 50/1,000 cps, 90 watts.

Dimensions: Cabinet Mount: 20 $\frac{3}{4}$ " wide, 12 $\frac{1}{2}$ " high, 14 $\frac{1}{2}$ " deep. Rack Mount: 19" wide, 10 $\frac{1}{2}$ " high, 13 $\frac{1}{2}$ " deep. Also can be used with *-hp-* AC-17 End Frames.

Weight: Net 37 lbs. Shipping 80 lbs. (cabinet mount).

Accessories Available: AC-16A/B Cable Assembly. AC-60B Transformer (for bridging input).

Data subject to change without notice.

hp 350 ATTENUATORS



Specifications

Two models are available. The *-hp-* 350A matches a 500 ohm impedance and the *-hp-* 350B matches a 600 ohm impedance (one side grounded).

Attenuation: The attenuation is 110 db in 1 db steps.

Accuracy: From 0 - 100 KC.

10 db Attenuator Section: Error less than 0.125 db at any step.

100 db Attenuator Section: Error less than 0.25 db any step up to 80 db attenuation, less than 0.5 db on 90-100 db steps.

Dimensions: Cabinet Mount: 8 $\frac{1}{8}$ " wide, 5 $\frac{1}{4}$ " high, 5 $\frac{1}{2}$ " deep. Rack Mount: 19" wide, 5 $\frac{1}{4}$ " high, 4 $\frac{7}{8}$ " deep.

Weight: Net 3 lbs. Shipping 7 lbs. (cabinet mount).

Accessories Available: AC-16A/B Cable Assembly.

Data subject to change without notice.

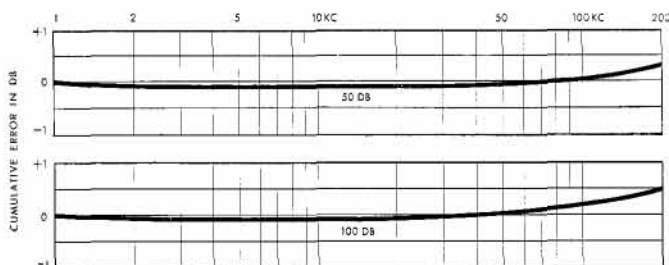

Figure 1. Typical Frequency Response.

A Basic Bridged-T Instrument With Many Laboratory Uses

WHEN a high order of accuracy, wide-frequency response, large-power handling capacity or other special features are required, *-hp-* 350 series Attenuators are of great value and convenience. They are particularly useful in attenuating output of audio and supersonic oscillators, measuring gain and frequency response of amplifiers, measuring transmission loss and increasing the scope and usefulness of other laboratory equipment.

Two basic bridge-T circuits make up the *-hp-* 350 Attenuators. One circuit is a 100 db attenuator, adjusted in 10 db steps. The other is a 10 db attenuator, adjusted in 1 db steps. Frequency response is flat to 100 KC (See Figure 1). The attenuators are available in two standard impedance levels—500 and 600 ohms. Resistors are adjusted to $\pm 0.5\%$ for maximum calibration accuracy. The instruments have large-power handling capacity—5 watts—and are ideal for supersonic and other work involving measurements above the range of conventional audio-frequency attenuators.

For power gain measurements or to form a signal generator, use *-hp-* 350 Attenuator with an *-hp-* oscillator and a voltmeter.

VACUUM TUBE *hp* VOLTMETERS

THE measurement of voltage is a basic electrical function which is required almost daily in the research laboratory, on the production line and in the operation of electrical, electronic and mechanical equipment.

For maximum speed and convenience in making measurements from 2 cps to 700 MC, Hewlett-Packard offers three stable, accurate vacuum tube voltmeters. Each gives you familiar *hp*- characteristics of wide range, compact size, sturdy dependability and time-saving ease of operation.

High-Sensitivity Voltmeters

hp- Models 400AB (page 36) and 400D (page 32) are high-sensitivity average-reading instruments. In these voltmeters the dc current through the indicating meter is proportional to the average value of the ac voltage under

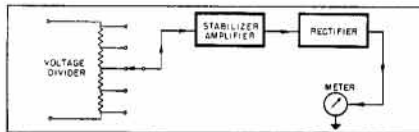

Figure 1. Block diagram, *hp*- 400 series voltmeters.

measurement. Circuits include an input voltage divider, a stabilized amplifier with generous feedback, rectifier and meter circuits and a power supply. (Figure 1.) Operation is independent of the tube characteristics and line voltage changes.

hp- Model 400D Voltmeter is particularly useful in measuring very small voltages down to 1 mv full scale and can also be used as a high-gain broadband amplifier to increase sensitivity of oscilloscopes, bridges, etc. It measures voltages throughout the audio, supersonic and low rf regions and is also excellent for geophysical and telemetering work, and the measuring of power circuits and high frequency voltages in broadcast equipment.

Wide-Range Voltmeters

hp- Model 410B (page 34) is a wide-range peak-reading voltmeter designed especially for high-frequency work (20 cps to 700 MC). It has a high input resistance with minimum shunt capacity and can be connected into a circuit without introducing stray capacity. This instrument employs a special probe with a custom-designed diode tube. The cathode of this probe diode has solid grounding, and the anode lead is brought out with a minimum of inductance. Model 410B is independent of line voltage changes and offers highly stable performance ideal for audio, supersonic, rf or uhf measurements.

Voltmeter Accessories

To increase the useful range of *hp*- voltmeters, a complete line of voltmeter accessories is offered (page 37). These include Probe Connectors, Capacitive Voltage Dividers, dc Resistive Voltage Multipliers, Shunt Resistors, etc.

Voltmeter Operating Techniques

In average-reading voltmeters such as *hp*- 400AB and 400D, the meter indicates rms value of a true sine wave. When the waveform of the voltage under study contains appreciable harmonic or other spurious voltages, measurement errors will be encountered. The magnitude of the error will de-

% Harmonic	True Rms Value	Model 400D Indication	Peak Meter Indication
0	100	100	100
10% 2nd.	100.5	100	90 to 110
20% 2nd.	102	100-102	80 to 120
50% 2nd.	112	100-110	75 to 150
10% 3rd.	100.5	96-104	90 to 110
20% 3rd.	102	94-108	88 to 120
50% 3rd.	112	90-116	108 to 150

Table 1. Measurement errors from harmonic or other spurious voltages.

pend on the magnitude and phase relationship between harmonic and fundamental frequencies. Average reading voltmeters give superior accuracy to peak-reading voltmeters when complex waves are measured. Table 1 gives an indication of the limits of possible error due to the presence of harmonics in the waveforms to be measured. This table is universal in its application since these errors are inherent in all voltage measuring equipment of the average reading or peak reading variety.

Voltmeter readings can be affected by hum pick-up when the circuit under study has a high impedance. Ordinary shielded leads reduce such pick-up, but are often not practical. In such cases, *hp*- 454A Capacitive Voltage Divider is recommended (page 37). This instrument is a capacitive probe which presents a very high impedance to the point of measurement and provides a thoroughly shielded lead to the VTVM. This results in a sensitivity loss of 100:1 in the voltmeter.

In measuring voltage at very high frequencies, even very short leads can introduce reactance which results in meter error. When using the probe of *hp*- 410B voltmeter for high frequency work, it is advisable to ground the outer shell of the probe with heavy copper strapping and keep the distance from the probe to the point of measurement as short as possible. The nose of the probe is removable when the ultimate in short leads is desired.

To facilitate measurement in coaxial transmission lines with *hp*- 410B voltmeter, *hp*- 455A Probe Coaxial "T" Connector is offered (page 37). This instrument is a specially designed "T" joint which connects the probe into the line without disturbing conditions in the line.

Low Frequency Operation

The *hp*- 400D may be modified on special order for operation at frequencies as low as 2 cps.

hp 400D VACUUM TUBE VOLTMETER



Advantages:

- Extremely wide voltage range
- Accurate within 2% to 1 MC
- Broadest frequency coverage
- 10 megohm input impedance
- No switching transients
- High sensitivity, stability
- Reads direct in dbm
- Light, small, portable

Use It To Measure:

- Audio, supersonic, rf voltages
- Amplifier gain. Network response
- Output level. Hum level
- Power circuit voltages
- Video or carrier current voltages
- Capacity. Coil figure of merit

10 cps to 4 MC! Successor to 10,000 Model 400C's!

THE *hp*-400D Vacuum Tube Voltmeter is a completely new instrument incorporating features never before combined in one voltmeter. It is the finest vacuum tube voltmeter built today.

Frequency coverage is 10 cps to 4 MC. The 400D has a new amplifier providing approximately 56 db of feedback in mid-range. This assures highest stability and freedom from calibration change due to external conditions. A special switching arrangement in the cathode circuit minimizes switching transients while ranges are being changed. Input impedance is 10 megohms, assuring that circuits under test are not disturbed by loading. New output circuitry makes possible the use of the instrument as a broad band, high gain amplifier over its full frequency range.

Highest Quality Construction

Model 400D is protected against overloads as great as 600 volts on all ranges. Its indicating meter is a special 1%, 1 milliamper instrument with a large 4" scale and

knife-edge pointer. All coupling and bypass condensers are sealed, and electrolytic condensers are long-life types designed for more than 10 years of trouble-free service. Circuitry and mechanical layout are clean and permit easy access to all parts. A rugged new streamlined metal case insures handling ease and portability, and occupies minimum bench space. Fold-out front legs tilt the instrument for more convenient reading angle when desired.

This new instrument includes the tested features of the reliable *-hp-* 400C Vacuum Tube Voltmeter, over 10,000 of which are in use in laboratories, service and production organizations today. The 400D provides a wider frequency range, improved accuracy, and even greater stability for line voltage variation and tube aging than was available with the popular Model 400C. In addition, it is freshly styled to harmonize with the Hewlett-Packard line of compact, portable instruments.

Simple Operation

-hp- instruments are noted for their simple, straightforward operation; Model 400D is particularly easy to use. Ranges are quickly selected on a front panel switch which changes sensitivity in precise 10 db steps. This, plus calibration of the meter in db, means direct readings are available without calculation or conversion between -72 and $+52$ dbm. (0 dbm = 1 mw in 600 ohms.) Meter voltage scales are arranged in multiples of $1, 3, 10, 30$, etc., so that readings are always in the upper two-thirds of the scale where maximum accuracy is obtained.

Typical variations in accuracy resulting from line voltage changes and tube aging are shown in Figure 1. The exceptional stability of the 400D amplifier section is clearly shown by these graphs.

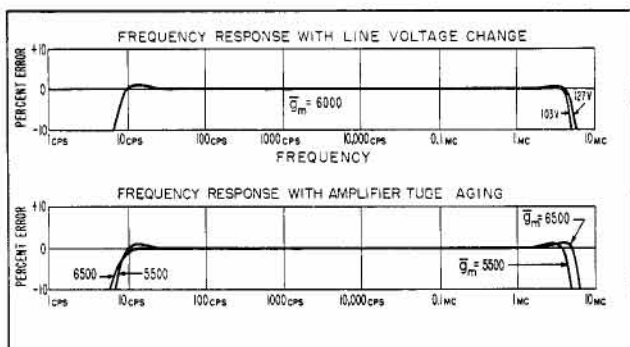

Figure 1. Typical variation in accuracy with line voltage changes and mutual conductance changes (geometric mean value of amplifier tubes).

New Broad Usefulness

In speed, accuracy and versatility the 400D is unmatched. It may be used for measuring amplifier gain, network response, output level, and almost all audio and rf voltages as well as video and TV voltages. In many instances, the voltmeter will also measure hum and noise directly besides determining power circuit and broadcast high frequency voltages. It further serves as an audio level meter, a high gain

broad band amplifier; it detects nulls, monitors waveforms (in conjunction with an oscilloscope).

In conjunction with an oscillator, the 400D can be used to measure wide ranges of L and C as well as moderate ranges of R and Z . The 400D can also be used as the indicating device in measuring coil Q .

Specifications

Voltage Range: 0.1 millivolt to 300 volts. 12 ranges, front panel switch. Full scale readings from 0.001 to 300 volts.

0.001	0.03	1	30
0.003	0.1	3	100
0.01	0.3	10	300 volts

Frequency Range: 10 cps to 4 megacycles.

Accuracy: With line voltages of $\pm 10\%$ (103 volts to 127 volts), overall accuracy is $\pm 2\%$ of full scale, 20 cps to 1 MC; $\pm 3\%$ of full scale, 20 cps to 2 MC; $\pm 5\%$ of full scale, 10 cps to 4 MC.

Long Term Stability: Reduction in G_m of amplifier tubes to 75% of nominal value results in error of less than 0.5% , 20 cps to 1 MC.

Calibration: Reads rms value of sine wave. Voltage indication proportional to average value of applied wave. Linear voltage scales, 0 to 1 and 0 to 3 ; db scale, -12 db to $+2$ db, based on 0 dbm = 1 mw in 600 ohms, 10 db intervals between ranges.

Input Impedance: 10 megohms shunted by $15 \mu\text{mf}$ on ranges 1 to 300 volts; $25 \mu\text{mf}$ on ranges 0.001 to 0.3 volts.

Amplifier: Output terminals are provided so voltmeter can be used to amplify small signals or to monitor waveforms under test with an oscilloscope. Output approximately 0.15 volts rms corresponding to full-scale meter deflection. Internal impedance, 50 ohms. Gain approximately 150 for 0.001 volt range.

Power: $115/230$ v $\pm 10\%$, $50/1,000$ cps, 70 watts.

Dimensions: Cabinet Mount: $7\frac{1}{4}$ " wide, $11\frac{1}{4}$ " high, $11\frac{3}{4}$ " deep. Rack Mount: 19 " wide, 7 " high, 11 " deep.

Weight: Net 18 lbs. Shipping 32 lbs. (cabinet mount).

Accessories Available: AC-16A/B Cable Assembly. *-hp-* 470A—F Shunt Resistors. *-hp-* 452A Capacitive Voltage Divider. *-hp-* 454A Capacitive Voltage Divider. *-hp-* AC-60A/B Line Matching Transformers.

Data subject to change without notice.

hp 410B VACUUM TUBE VOLTMETER



Advantages:

- Range: 20 cps to 700 MC
- Input capacity, approximately $1.5 \mu\text{mf}$
- High input impedance
- Few controls. High stability
- Rugged meter movement
- Excellent overload protection

Use It To Measure:

- Audio frequency, supersonic, rf, and vhf voltages
- Antenna voltage, current, and power
- Transmission line characteristics
- Standing waves
- Audio, video and vhf amplifiers
- Dc voltage in high impedance circuits

All-Purpose Test Instrument Measures to 700 MC

BECAUSE of the tremendous number of tasks it will perform, the 410B High Frequency Vacuum Tube Voltmeter can play a uniquely valuable role in any laboratory, broadcast station, or production test department. It combines in one instrument an ac voltmeter covering the frequency range from audio to radar frequencies, a dc voltmeter with more than 100 megohms input impedance, and an ohmmeter capable of measuring resistance from 0.2 ohms to 500 megohms. In addition, it is easy to use, compact, portable, and light in weight.

A special probe, employing a radically different diode especially designed for Hewlett-Packard, is used for making ac measurements. The resonant frequency of the

diode is approximately 1500 MC, and the shunt capacity is extremely low. Mounted in the probe, it places a capacity of approximately $1.5 \mu\mu\text{f}$ across the circuit under test. Total input impedance at low frequencies for ac measurements is 10 megohms shunted by this capacity.

The 410B employs a high impedance dc voltmeter having a special circuit developed by *-hp-* engineers. Its outstanding feature is low drift and maintenance of calibration over long periods of time. Only one zero adjustment is necessary for all voltage ranges, and once set it rarely needs adjustment. This circuit permits the use of a 1 ma meter movement which together with certain features of the circuit itself makes it impossible to damage the meter by overloads. Input impedance for dc measurements is more than 100 megohms for all ranges.

Uses

The versatility of the 410B is so great that the number of uses to which it may be put is almost endless. As an ohmmeter it will accurately measure resistance over a much wider range than is ever ordinarily encountered. As a dc voltmeter, its extremely high input impedance permits its use on almost any equipment without any appreciable loading of the circuit.

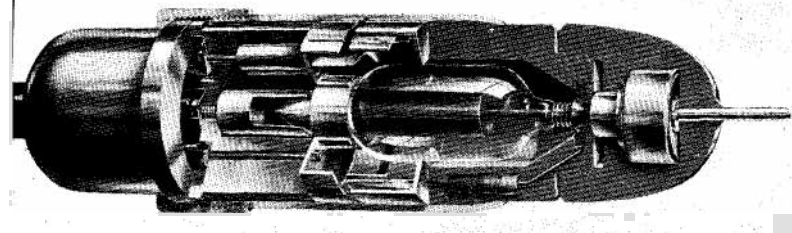
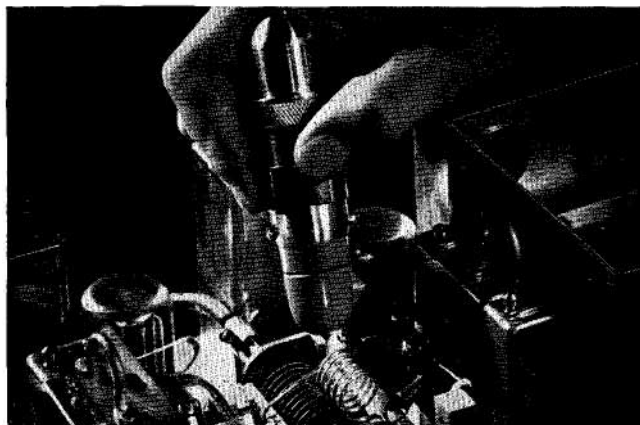

Figure 1. Construction details of *-hp-* diode probe.

As an ac voltmeter, its combination of high input impedance with great frequency range sets altogether new standards of performance. The probe can be inserted in almost any audio, supersonic, radio, or vhf amplifier without detectable loading of the circuit. It can be used to measure antenna and transmission-line voltage, current, and power with as much ease and convenience as if the circuits carried dc. Special adapters can be supplied for use with the probe to connect to standard transmission lines.

Finally, the fact that all these functions are combined in one instrument means that where previously a whole battery of equipment might be required to test a given piece of apparatus, the 410B, in one small, convenient, and highly portable instrument, does the whole job. Leads are provided for all functions so that it is necessary only to change the position of switch for selecting any particular operation. Storage space for leads and probes is provided at the rear of the instrument cabinet.



hp 400AB VACUUM TUBE VOLTMETER



Specifications

Voltage Range: 0.3 mv to 300 volts. 12 ranges, selected with front panel switch. Full scale readings of:

0.003 volts	0.1	3.0	100
0.01	0.3	10.0	300
0.03	1.0	30	

Frequency Range: 10 cps to 600 KC.

Accuracy: With nominal line voltage $\pm 10\%$ (103 volts to 127 volts), overall accuracy is within $\pm 2\%$ of full scale, 20 cps to 100 KC, $\pm 3\%$ 10 cps to 600 KC.

Calibration: Reads rms value of sine wave. Voltage indication proportional to average value of applied wave. Linear voltage scales, 0 to 3 and 0 to 1.0; db scale, -12 db to $+2$ db, based on 0 dbm = 1 mw in 600 ohms, 10 db intervals between ranges.

Input Impedance: 10 megohms shunted by 25 μ f.

Amplifier: Output terminals are provided so voltmeter can be used to amplify small signals or monitor waveforms under test with an oscilloscope.

Power: 115/230 volts $\pm 10\%$, 50/1,000 cps, approximately 70 watts.

Dimensions: 11 $\frac{1}{4}$ " high, 7 $\frac{1}{4}$ " wide, 7" deep (cabinet mount). Rack mounting available on 19" x 7" panel.

Weight: Net 15 lbs. Shipping 25 lbs. (cabinet mount).

Accessories Available: AC-60A Line Matching Transformer. 452A Capacitive Voltage Divider. 454A Capacitive Voltage Divider. 470A-470F Shunt Resistors.

Data subject to change without notice.

New! Moderate Price!
10 cps to 600 KC

HERE IS a new *-hp-* precision voltmeter offering the utmost in utility, dependability and dollar value. Model 400AB replaces the famous Model 400A in the *-hp-* line; it retains the proven quality and convenience features of the earlier instrument yet embodies many important improvements. Frequency coverage is broad—10 cps to 600 KC. Measurements may be made from 0.3 millivolt to 300 volts. Stability and sensitivity are extremely high, and accuracy is $\pm 2\%$ full scale from 20 cps to 100 KC, $\pm 3\%$ down to 10 cps and up to 600 KC. Input impedance is high to prevent disturbance to circuits under test. The meter reads direct in voltage and dbm, and a generous overload capacity eliminates need for special operating precautions. Model 400AB is the most compact of all *-hp-* voltmeters, occupying only a 7" square area of bench space.

Broad Usefulness

Model 400AB is particularly suited for measuring amplifier gain, network response or output level on audio, carrier current and supersonic ranges. In many applications it will give direct measurement of hum and noise level. It measures very small differential voltages and serves as a null indicator. An output connector is provided so the voltmeter may be used as an amplifier. With an oscilloscope, the instrument also monitors waveform of a voltage under test.

VOLTMETER ACCESSORIES

EXTEND the usefulness of your present *-hp-* voltmeters with these new precision built *-hp-* accessories. Custom-designed for use with *-hp-* Models 400AB, 400D or 410B Vacuum Tube Voltmeters. Save time and work, simplify tedious jobs. Make fast, accurate measurements far beyond the original range of your instruments.

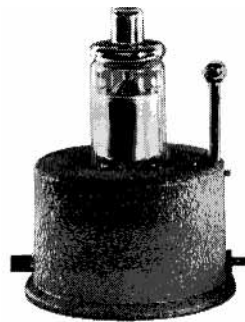

-hp- 452A Capacitive Voltage Divider

For *-hp-* 400AB, 400D and 410B. Safely measures power voltages to 25 kv. Accuracy $\pm 3\%$. Division ratio 1000:1. Input capacity $15 \mu\text{f} \pm 1$. Max. voltage ratings at 60 cps, 25 kv; 100 KC, 22 kv; 1 mc, 20 kv; 10 MC, 15 kv; 20 MC, 7 kv. Usable for dielectric heating, power and supersonic voltages. **452A-95A Adapter:** To connect *-hp-* 410B probe to shielded connector of *-hp-* 452A.



-hp- 453A Capacitive Voltage Divider

For *-hp-* 410B Voltmeter. Increases range so transmitter voltages can be measured quickly, easily. Accuracy $\pm 1\%$. Division ratio, 100:1. Input capacity approx. $2 \mu\text{f}$. Max. voltage 2,000 v. For frequencies 10 KC and above.



-hp- 458A Probe Coaxial "N" Connector

For *-hp-* 410B Voltmeter. Measures volts at open end of 50-ohm transmission line. (No terminating resistor.) Uses female type "N" fitting.

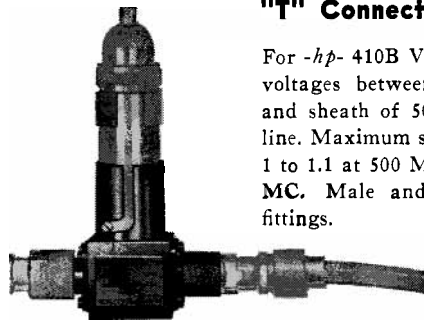

-hp- 455A Probe Coaxial "T" Connector

For *-hp-* 410B Voltmeter. Measures voltages between center conductor and sheath of 50 ohm transmission line. Maximum standing wave ratio 1 to 1.1 at 500 MC, 1 to 1.2 at 1,000 MC. Male and female type "N" fittings.

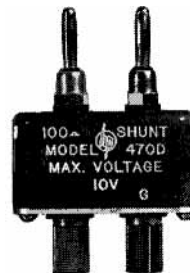

-hp- 470A-470F Shunt Resistors

For *-hp-* 400AB or 400D Voltmeters, to measure currents as small as $1 \mu\text{a}$ full scale. Accuracy $\pm 1\%$ to 100 KC, $\pm 5\%$ to 4 MC (470A, $\pm 5\%$ to 1 MC). Max. power dissipation 1 watt.

Instrument	Value
<i>-hp-</i> 470A	0.1 Ω
<i>-hp-</i> 470B	1 Ω
<i>-hp-</i> 470C	10 Ω
<i>-hp-</i> 470D	100 Ω
<i>-hp-</i> 470E	600 Ω
<i>-hp-</i> 470F	1,000 Ω



-hp- 459A DC Resistive Voltage Multiplier

For *-hp-* 410B Voltmeter. Gives maximum safety and convenience for measuring high voltages as in television receivers, etc. Accuracy $\pm 5\%$. Multiplication ratio 100:1. Input impedance 12,000 megohms. Max. voltage 30 kv. Max. current drain 2.5 microamperes.

-hp- 454A Capacitive Voltage Divider

For *-hp-* 400AB and 400D. Safely measure power, audio, supersonic and rf voltages. Accuracy $\pm 3\%$. Division ratio, 100:1. Input impedance 50 megohms, resistive shunted with $2.75 \mu\text{f}$ capacity. Max. voltage, 1,500 v.

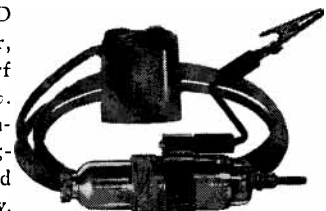

Data subject to change without notice.

450A AMPLIFIER



Specifications

Gain: 40 db $\pm \frac{1}{8}$ db or 20 db $\pm \frac{1}{8}$ db (Panel Switch).

Frequency Response: At 40 db gain: within ± 0.5 db between 10 and 1,000,000 cps; within ± 1 db between 5 and 2,000,000 cps. At 20 db gain: within ± 0.5 db between 5 and 1,000,000 cps; within ± 1 db between 2 and 1,200,000 cps.

Stability: $\pm 2\%$ with line voltage of 115 v ± 10 v and normal change in tube characteristics.

Input Impedance: 1 megohm shunted by approx. 15 μmf

Output: 10 volts maximum to 3,000 ohms or higher resistive load.

Internal Impedance: Less than 150 ohms over entire range.

Distortion: Less than 1% at rated output from 2 cps to 100 KC; approximately 5% above 100 KC to 1 MC.

Equivalent Input Noise Level: 40 db gain, 40 microvolts approx.; 20 db gain, 250 microvolts approx.

Power: 115/230 v $\pm 10\%$, 50/1,000 cps, 40 watts.

Dimensions: Cabinet Mount: 8 $\frac{1}{4}$ " wide, 5 $\frac{1}{2}$ " high, 10 $\frac{1}{2}$ " deep. Rack Mount: 19" wide, 5 $\frac{1}{4}$ " high, 10" deep.

Weight: Net 9 lbs. Shipping 22 lbs. (cabinet mount).

Accessories Available: AC-16A/B Cable Assembly.

Data subject to change without notice.

General Purpose Amplifier 20 db or 40 db Gain

THE *hp*- Model 450A Amplifier is ideal as a general purpose instrument wherever wide frequency range and stable gain are essential. The instrument has an extremely stable 20 db or 40 db gain over a continuous frequency range of 10 cps to 1,000,000 cps. Either gain may be quickly selected with a toggle switch on the front panel.

The amplifier is resistance-coupled and does not use peaking or compensating networks. Optimum performance is obtained entirely from a straightforward amplifier design in combination with inverse feedback. Phase shift is negligible, and there are no spurious oscillations or resonances.

This amplifier consists of two stages followed by a cathode follower output stage. Hum is kept to a minimum by using direct current filament supply for the two amplifier tubes.

AMPLIFIERS

HEWLETT - PACKARD offers five amplifiers covering a wide variety of measuring requirements.

General-Purpose Amplifier

-hp- 450A Amplifier (opposite page) is a general-purpose instrument, usable wherever wide frequency range and stable gain are desired. Because of a large amount of feedback, the instrument has an extremely stable 20 or 40 db gain over a continuous frequency range of 5 cps to 1 MC. In addition, it can be used up to 3 MC with some sacrifice in gain and stability.

Distributed Amplifiers

-hp- 460A and 460B Distributed Amplifiers (pages 40, 41) are wide-range amplifiers providing distortionless pulse amplification. They combine extremely short rise time with zero overshoot.

These instruments are employed to amplify pulses in the order of 0.01 microsecond. They provide suitable output for operating scalars or coincidence devices, or investigating characteristics of pulse circuitry in nuclear work or television, uhf and vhf networks. They increase sensitivity of oscilloscopes and voltmeters and are useful for other amplification purposes up to 200 MC. Response is substantially constant down to 100 KC.

Operating Techniques

-hp- 460A is a voltage amplifier having approximately 20 db gain with a maximum output of 8 volts into an open circuit which is sufficient for operating scalars, etc. For higher voltages required for cathode ray tube deflection, *-hp-* 460B is recommended. This instrument is a wideband amplifier designed to supply a maximum of 125 volts peak (negative) open circuit. This is sufficient to provide full deflection on any commonly-used cathode-ray tube. One or more 460B amplifiers can be cascaded with one or more 460A amplifiers to provide a high-gain pulse amplifier with very rapid rise time and zero overshoot (see Figure 1).

Cascading Amplifiers

When cascading distributed amplifiers, consideration must be given to the polarity as well as the amplitude of pulse to be amplified. Model 460B, unlike Model 460A, consists of a single stage and will invert the polarity of the applied pulse. Hence an additional Model 460B can be used to invert the polarity whenever it is necessary to do so. For maximum deflection on the cathode-ray tube, the set-up must be arranged so that the input to the last amplifier is positive and of approximately 8 volts peak amplitude. This can be achieved by preceding the final 460B with another 460B.

The rise time of amplifiers in cascade is greater than that of a single amplifier by $T \times (n)^{1/2}$; where n is the number of 460 amplifiers in the system and T is the rise time of one 460 amplifier (2.6×10^{-9} seconds.) In addition, the rise time of the RC combination formed by the capacity of CRT deflection plates and the internal impedance of the 460B (200 ohms) should be considered. The rise time of a type 5XP-tube driven from a 200-ohm source is approximately 2×10^{-9} seconds. (A chain of five *-hp-* 460 amplifiers with a 5XP CRT will result in a rise time of 6.1×10^{-9} seconds.)

Traveling-Wave Tube Amplifiers

Hewlett-Packard 490A and 491A Traveling-Wave Tube Amplifiers (pages 42, 43) are high gain broad band linear devices covering the frequency range of 2 to 4 KMC. They may be used to amplify the output of signal generators. *-hp-* 490A may be used to modulate rf signals with pulses of millimicrosecond rise and decay time. They are also suitable as broad-band rf amplifiers for receiver and detector applications.

-hp- Model 490A is intended primarily for high gain, low level application. It provides at least 35 db amplification, with a noise figure of not more than 25 db above theoretical. It can be pulse modulated.

-hp- Model 491A provides an output power of at least 1 watt over the entire "S" band frequency range. This output, when coupled with the instrument's 30 db gain, makes it possible to use 491A with a standard 1 milliwatt "S" band signal generator (such as *-hp-* 616A) to provide a flexible 1 watt source in the 2 to 4 KMC band.

Noise Consideration in Amplifiers

The limit of minimum useful input signal level of an amplifier is determined by random varying voltages and currents present in the circuit and tubes.

In distributed amplifiers, the noise figure is proportional to $1/\sqrt{n}$, where n is the number of tubes in the first stage. *-hp-* 460B has less internal generated noise than *-hp-* 460A (460B has 13 tubes in the first stage whereas 460A has only 5). *-hp-* 460B should thus be used to start a cascade chain when extremely small signals are to be examined.

-hp- 490A/491A Traveling-Wave Tubes have low noise figures but due to their extreme band width they have a large theoretical thermal noise power. When cascading two amplifiers for increased power gain, the system will approach saturation due to this noise level. Cascading the amplifiers will provide a source of noise power approaching white noise for the frequency spectrum. If narrow band amplification is desired, a band pass filter may be used following the first amplifier. This will decrease the theoretical thermal noise power and increase the signal-to-noise ratio of the system.

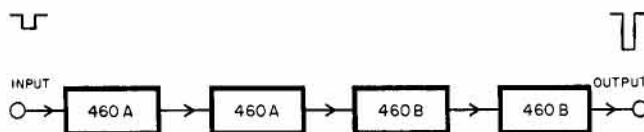
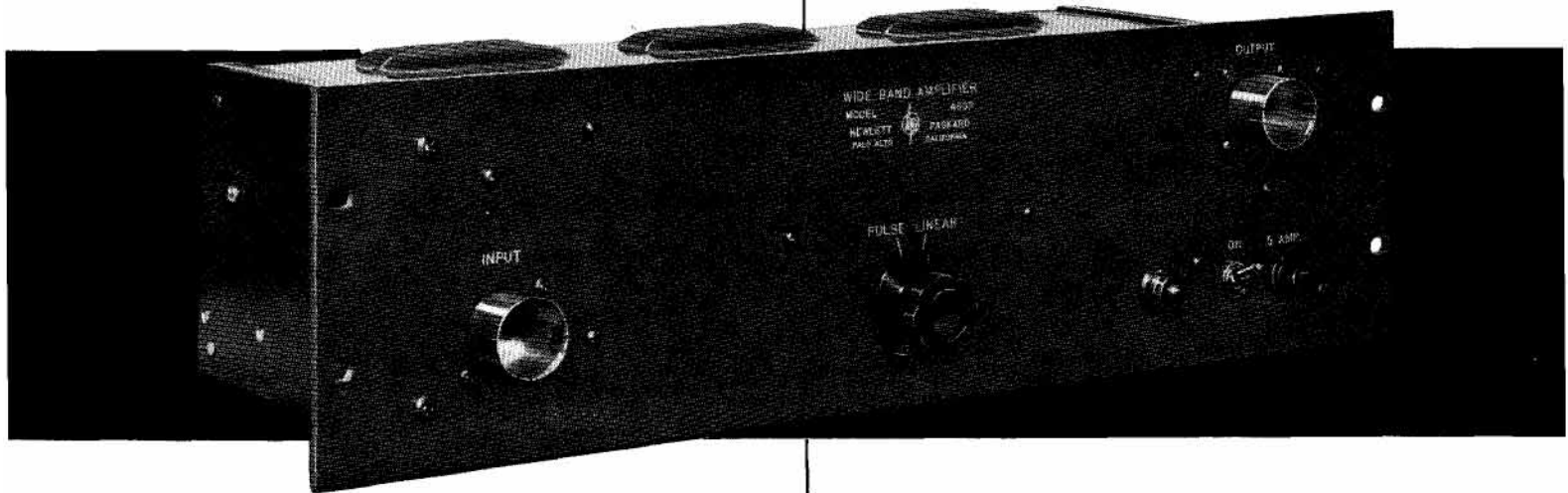

Figure 1. Typical cascading of 460A/B Amplifiers to give approximately 70 db gain and 125 volt pulse output.

hp 460A/B WIDE-BAND AMPLIFIERS



Advantages:

- 20 db gain—up to 90 db in cascade
- True amplification of millimicrosecond pulses
- Rise time .0026 μ sec
- No ringing or overshoot
- 125-volt open circuit output
- Response follows Gaussian curve

Uses:

- Fast-pulse nuclear work
- TV, vhf, uhf, shf research
- Simplifies measurement of small outputs
- 100 MC pre-amplifier for oscilloscope
- Increases VTVM sensitivity 10 times over 200 MC range
- General laboratory amplifier

Wide-Band Distortion-Free Fast-Pulse Amplifiers

MODEL 460A/B Amplifiers make it possible for you to obtain at moderate cost true amplification of fast pulses at power levels sufficient to operate scalars, counting meters and cathode ray tubes.

-hp- 460A Wide-Band Amplifier is used fundamentally to provide voltage gain. (Approximately 20 db.) Its companion equipment, -hp- 460B, is designed as a terminal amplifier to give maximum voltage or power output. The amplifier's ultra-short rise time of .0026 μ sec, combined with zero overshoot, insures distortion-free amplification of pulses faster than 0.01 μ sec. -hp- 460B cascaded with 460A provides linear amplification of 16 volts peak output; and with two 460B, pulse amplification of 125 volts (open circuit limited duty cycle.) This permits full deflection of 5XP cathode ray tubes or two inch deflection of 5CP tubes. (Slight non-linearity, *see Figure 3.*) This unusual combination gives maximum usefulness for fast-pulse nuclear radiation problems, television, vhf, uhf or shf work. It also means the bandwidth of your standard oscilloscope can be increased to over 100 MC, and voltmeter sensitivity multiplied by 10. In cascade or singly, the amplifiers offer still further convenience as general-duty wide-band amplifiers for all types of laboratory problems.

Operation

-hp- 460A represents a new type of amplifier with a very wide transmission band—approximately 200 MC. The equipment has two stages of 5 and 7 tubes, respectively.

Tube grids are connected along one transmission line to form the input circuit. Tube plates are connected along a second transmission line, forming the output circuit. A wave, traveling along the input line, excites the grids in succession; half the corresponding wave (generated in the plate circuit) travels down the plate toward the output. This wave is reinforced at each successive plate.

The part of the wave in the plate line which travels in the reverse direction is absorbed by a termination at the opposite end of the line. By the time the wave in the plate line reaches the output, it has been amplified by about 10 db. The second stage of the amplifier also increases the gain by approximately 10 db, making a total approximate gain of 20 db for the unit.

-hp- 460B operates on a similar principle except that it consists of one long amplifier chain or a single stage providing maximum power and voltage output but somewhat lower gain (approx. 15 db).

The precise accuracy with which this equipment amplifies very fast pulses can be seen in Figure 1. The view at left (a) shows a 0.01 μ sec pulse applied through one *-hp- 460B* Amplifier. The view at right shows a 0.02 μ sec pulse applied through 3 amplifiers in cascade. Note the very short rise time and the complete absence of overshoot or ringing.

Response is shown in Figure 2. The curve follows the Gaussian norm very closely, even to a point well beyond 200 MC. This response also indicates how the amplifiers can be used with a vacuum tube voltmeter such as *-hp- 410B* (see pages 34, 35) to increase voltmeter sensitivity up to 10 times. In this combination, accurate readings are easily made of voltages as small as .01 volts, at frequencies from 200 KC to 200 MC.

200-Ohm Coaxial System

Since the best interconnecting impedance level for these amplifiers is 200 ohms, *-hp-* has designed Series 46A accessories comprising a complete 200-ohm coaxial system of connectors and cables. These include leads with fittings, panel jacks and plugs, adapters to connect to a 50-ohm Type N system and a special adapter for use with *-hp- 410B* Vacuum Tube Voltmeter. (See Specifications for details.)



Figure 1. (a) 0.01 μ sec pulse through *-hp- 460B* Amplifier. (b) 0.02 μ sec pulse through 3 amplifiers in cascade.

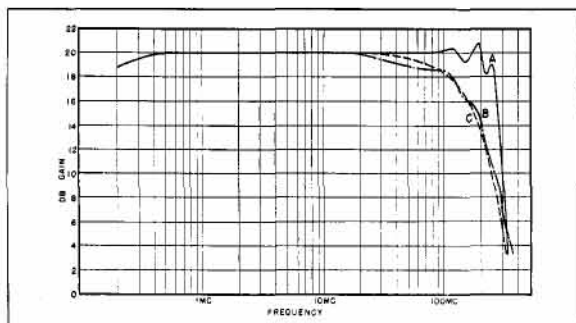

Figure 2. Typical response of 460A Amplifier working into (B) resistive load and (A) using *-hp- 410B* Vacuum Tube Voltmeter. (C) Gaussian curve.

Specifications

*-hp- 460AR**

Frequency Response: *High frequency*—closely matches Gaussian curve when operating into a 200-ohm resistive load. 3 db point is 140 MC. *Low frequency*—when operating from a 200-ohm source and .01 μ f blocking condenser, frequency response off 3 db at 3 KC into an open circuit or succeeding amplifier. When operating into a 200-ohm load, off 3 db at 100 KC. With *-hp- 410B* VTVM: ± 1 db, 200 KC to 200 MC.

Gain: Approximately 20 db into 200-ohm load. Gain control has range of 6 db. 5 amplifiers may be cascaded.

Output: Approx. 8 v peak open circuit. Internal impedance, 300 ohms.

Input Impedance: 200 ohms.

Noise Figure: Less than 10 db.

Delay Characteristics: Approx. .014 μ sec.

Rise Time: Approx. .0026 μ sec (10% to 90% amplitude). No appreciable overshoot.

Power: 115 v ± 10 v, 50/1,000 cps, 35 watts.

Dimensions: Rack Mount: 19" wide, 5 $\frac{1}{4}$ " high, 7" deep.

Weight: Net 11 lbs. Shipping 28 lbs.

Accessories Available: 46A-16A/B Cable Assembly. 46A-95A-G Jacks, Plugs, Adapters, Connector Sleeves. 812-52 200-ohm Cable Assembly.

*-hp- 460BR**

(Same as 460A except as follows:)

Gain: Approximately 15 db into 200-ohm load.

Output: Linear Amplifier—Approximately 8 volts peak into a 200-ohm load or 16 volts peak into open circuit.

Pulse Amplifier—Approximately 125 volts negative peak into open circuit (unilateral pulse operation).

Input: Impedance 200 ohms (+8 volts input required for -125 volt output).

Duty Cycle: 0.10. Higher duty cycles may be employed at sacrifice of output voltage.

Delay Characteristics: Approx. .016 μ sec.

Noise Figure: Less than 6 db.

*AR and BR designate rack mount. Cabinet mount not available.

-hp- 46A Accessories

-hp- 46A-16A Patch Cord—200 ohms, 2' long. \$14.50.

-hp- 46A-16B Patch Cord—200 ohms, 6' long. \$23.50.

-hp- 46A-95A Panel Jack—For 200-ohm cables, low capacitance. \$5.00.

-hp- 46A-95B Cable Plug—For 200-ohm systems. \$5.00.

-hp- 812-52 Cable—200-ohm cable in length to specification. Per foot \$2.25.

-hp- 46A-95C 50-Ohm Adapter—Type N connector for coupling 50-ohm line into *-hp-* amplifiers. \$10.00.

-hp- 46A-95D Adapter—Bayonet sleeve for connecting *-hp- 410B* VTVM to output of 460A amplifiers. \$10.00.

-hp- 46A-95E Connector Sleeve—Joins two 46A-95B Cable Plugs. \$7.50.

-hp- 46A-95F Adapter—For connecting to 5XP CRT. \$7.50.

-hp- 46A-95G Adapter—For connecting to Tektronix type 511 oscilloscope. \$12.50.

Data subject to change without notice.

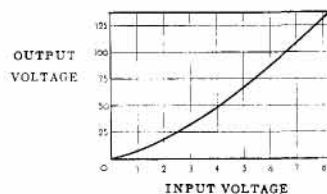

Figure 3. Linearity of *-hp- 460B* Amplifier.

hp 490A/491A TRAVELING-WAVE TUBE AMPLIFIERS



Advantages:

- Radically new coupled-helix design
- Full "S" band coverage—2 to 4 KMC
- High power 1 watt output
- 30 or 35 db gain
- Millimicrosecond pulse modulation
- Compact, portable, easy to use
- Capsulated replacement tubes

Use For:

- Pre-amplification of receivers and detectors
- Measuring antenna patterns
- Measuring wide range attenuators
- High power measurements
- Low level, low noise amplification
- High speed pulse generation

Broad Band High Gain Low Noise Amplification

NEW Hewlett-Packard 490A and 491A Traveling-Wave Tube Amplifiers are precision, broad band linear instruments making readily available a group of measurements hitherto almost unobtainable.

Such instruments were first described in 1946. But until development of the -hp- 490A and 491A, the problem of coupling broad band signals into and out of the tube had not been satisfactorily solved, and the radio industry had had no dependable, practical instruments of this type.

Radical New Design

-hp- engineers developed a simple new broad band coupling method employing helices. (Figure 1.) There is no mechanical connection to the inner helix, yet full energy transfer is effected. The difficulties in previous experimental amplifiers using multi-element networks, taper or vacuum leads have been overcome with matching helical couplers at both input and output ends of the tube. A similar helix is used for a coupled attenuator which surrounds the central portion of the tube, preventing amplified energy from causing regeneration.

Two Instruments Offered

To provide high power output, high gain, good noise figure and pulse modulation throughout the "S" band, *-hp-* offers two separate, self-contained amplifiers.

-hp- 490A is designed for high gain, low level applications. It provides at least 35 db gain, with noise level of less than 25 db and remarkably good pulse modulation characteristics. (Figure 2.)

-hp- 491A has a full range output of 1 watt, with minimum gain of 30 db. This instrument, together with a 1 milliwatt "S" band signal generator such as *-hp-* 616A, (see section on Signal Generators in this catalog) provides a versatile full watt source for high power testing 2 to 4 KMC. When modulated output is desired, the 616A may be modulated and the 490A will faithfully amplify the modulated signal.

Simple Controls

Both *-hp-* 490A and 491A have simple controls for varying traveling-wave tube anode and helix voltages for best performance. The anode voltage adjustment increases tube life by lowering dissipation when maximum output power is not required. The helix voltage adjustment allows maximum tube performance at any frequency. (A single setting of this control will provide rated output flat within 2 db over full range.)

For performance evaluation or continuous monitoring, a panel meter and selector provide for measurement of cathode, anode, helix and collector currents. No adjustments are required during operation.

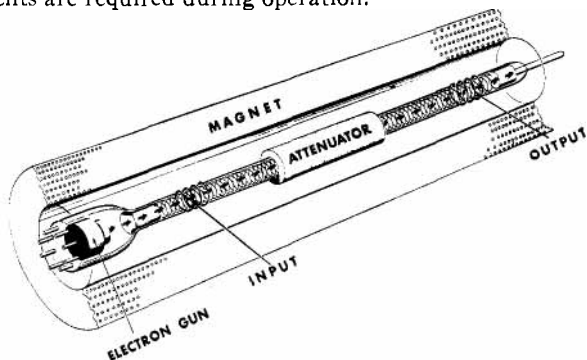

Figure 1. Construction of the *-hp-* Traveling Wave Tube showing input and output coupling helices and attenuator helix midway in the tube.

Capsulated Replacement Tubes

Adjustment of coupling helices used in *-hp-* Traveling-Wave Tubes is highly critical, and the tubes themselves are fragile. To eliminate field adjustment and need for excessive caution in handling, *-hp-* tubes are capsulated in an assembly which protects the tube and includes integral coupling helices. The capsule includes tube plugs and coaxial lines for insertion into the panel connectors on *-hp-* 490A and 491A Amplifiers. When delivered, the assembly is tested and ready for installation.

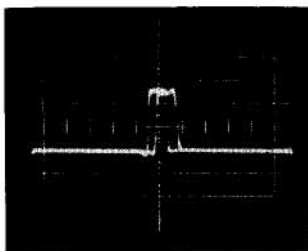
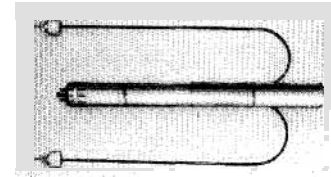

Figure 2. Unique modulating fidelity of *-hp-* 490A is shown in double-exposed oscillogram of 0.1 μ sec pulses. First pulse (applied by *-hp-* 212 Pulse Generator) is modulating pulse with rise time of 0.02 μ sec; delay through tube approximately 50 millimicroseconds. Second pulse is rf output. Note absence of deterioration.

Since many of the parts in the capsule assembly are reusable, credit is allowed for return of defective tube assemblies intact.

Figure 3. *-hp-* capsulated Traveling-Wave Tube. Note input and output coaxial lines with Type N plugs, and plug in base of tube, all mating with sockets in *-hp-* 490A and *-hp-* 491A Amplifiers.



Specifications

-hp- 490A

Frequency Range: 2 KMC to 4 KMC.

Gain: 35 db minimum.

Output Power: 10 milliwatts minimum.

Noise Figure: Less than 25 db.

Pulse Rise and Decay Time: Order of a few millimicroseconds.

Pulse Delay: Approximately 50 millimicroseconds.

Modulating Voltage: Requires approx. 50 volts peak negative to reduce output to 0.1% of initial value. Input impedance: 50 ohms.

Hum, Spurious Modulation: At least 30 db below signal level.

Meter Monitors: Cathode Current, Anode Current, Helix Current, Collector Current.

Connectors, Rf: Input and Output, Type N; Modulation Input, BNC.

Power: 115 v \pm 10 v, 50/60 cps, 125 watts.

Dimensions: Cabinet Mount: 7 $\frac{1}{4}$ " wide, 11 $\frac{1}{2}$ " high, 19 $\frac{1}{2}$ " deep.

Weight: Net 54 lbs. Shipping 93 lbs. (cabinet mount).

Accessories Furnished: 1 M-72 Power Cord.

Accessories Available: AC-16F rf Cable Assembly. AC-16K Video Cable Assembly.

-hp- 491A

Frequency Range: 2 KMC to 4 KMC.

Gain: 30 db minimum.

Output Power: 1 watt minimum.

Noise Figure: Less than 30 db.

Modulating Voltage: Modulation not provided.

Hum, Spurious Modulation: At least 30 db below signal level.

Meter Monitors: Cathode Current, Anode Current, Helix Current, Collector Current.

Connectors, Rf: Input and Output, Type N; Modulation Input, not provided.

Power: 115 v \pm 10 v, 50/60 cps, 250 watts.

Dimensions: Cabinet Mount: 7 $\frac{1}{4}$ " wide, 11 $\frac{1}{2}$ " high, 19 $\frac{1}{2}$ " deep.

Weight: Net 65 lbs. Shipping 104 lbs. (cabinet mount).

Accessories Furnished: 1 M-72 Power Cord.

Accessories Available: AC-16F rf Cable Assembly.

Data subject to change without notice.

FREQUENCY MEASURING EQUIPMENT

BY MEANS of electronic circuits, frequencies can be added, subtracted, multiplied and divided with mathematical exactness. When such circuits are used in conjunction with a high-quality frequency standard, measurements can be made whose precision approaches that of the standard to any desired degree.

Since a standard of frequency is by definition also a standard of time, frequency standards and measuring instruments are used in every branch of science and engineering where these quantities are considered. The complexity and precision of a frequency measuring instrument depends largely upon its application.

Frequency Standard

Until recently, the problem of obtaining standardized precisely-known frequencies has been solved by the use of elaborate and expensive primary frequency standards whose frequency is established by constant checks against standard time. However, the reliability and convenience of standardizing with Bureau of Standards transmis-

sions (Station WWV) have resulted in the recent widespread use of more economical secondary standards as a source of accurate frequency (Fig. 1).

Such an instrument is *-hp-* 100D Secondary Frequency Standard (page 46). This instrument contains a precision crystal oscillator which may easily be standardized against Station WWV. Five sinusoidal standard frequencies 100 KC, 10 KC, 1 KC, 100 cps, and 10 cps—are generated and the four lower frequencies are also available in rectangular waveshape. All of these frequencies are accurate to within a few parts in a million. A self-contained oscilloscope provides means of calibrating signal sources operating in the range of subsonic to radio frequencies by means of Lissajous figures. Harmonics as high as 5 MC can be obtained from the rectangular waves; and are useful in calibrating receivers or calibrating signal sources by zero-beat methods. This range can be extended by the use of multipliers.

TV and FM Monitors

-hp- offers Model 335E TV Monitor for the direct measurement and continuous display of visual carrier deviation, aural carrier deviation and percent of aural modulation for both monochrome and color TV. This widely-used instrument employs frequency counting circuits based on the *-hp-* RC pulse integrating circuit.

For FM, *-hp-* offers Model 335B FM Monitor. This instrument is similar to Model 335E for television except that the meters display aural carrier deviation and percent of aural modulation only.

-hp- Tachometry Instruments

Hewlett-Packard has drawn upon its experience with precision electronic counters to produce simplified and ver-

satile tachometry units tailored for industrial use. The individual components are designed for accurate analysis of most kinds of mechanical motion.

The tachometry equipment falls naturally in two general classes,

- A. Transducers which convert the mechanical motion to be measured into electrical pulses.
- B. Tachometer indicators which count these pulses or measure their time relationship.

These two general classes of instruments open the door to a wide variety of measurements with a degree of accuracy that has heretofore been unattainable.

Hewlett-Packard produces two general types of transducers and two general types of tachometer indicators.

Transducers

The two types of *-hp-* transducers are (1) Tachometer Generator, and (2) Optical Tachometer Pickup.

The Tachometer Generator is a low torque, compact generator which is used in the measurement of shaft revolutions. Or it can be used to determine the instantaneous rate of rotation for torsional vibration measurements. When the Tachometer Generator is connected to the rotating shaft it generates output pulses which can be counted in any of the *-hp-* counters. The Tachometer Generators are designed so that *-hp-* 508A provides 60 pulses per revolution, and *-hp-* 508B provides 100 pulses per revolution. Shaft revolutions of from 15 rpm to 40,000 rpm can be measured accurately with these tachometer generators.

Hewlett-Packard's other transducer, *-hp-* 506A Optical Tachometer Pickup, uses a light source and phototube receiver to generate its electrical pulses for counting purposes. For making rpm measurements, the light is directed upon the rotating shaft, which is prepared with alternate reflecting and absorbing surfaces. The reflected light is picked up by the photo cell, thus generating electrical impulses. The Optical Tachometer Pickup has the advantage that it does not load the machinery under test. It can be used

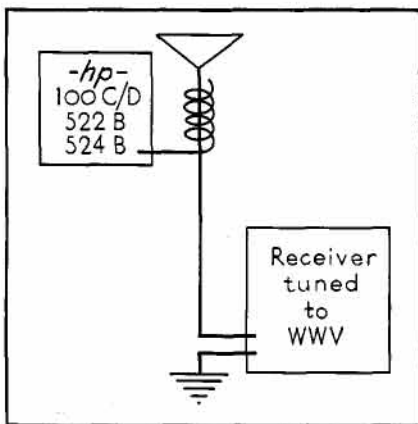

Figure 1. Method of checking *-hp-* frequency measuring equipment with station WWV.

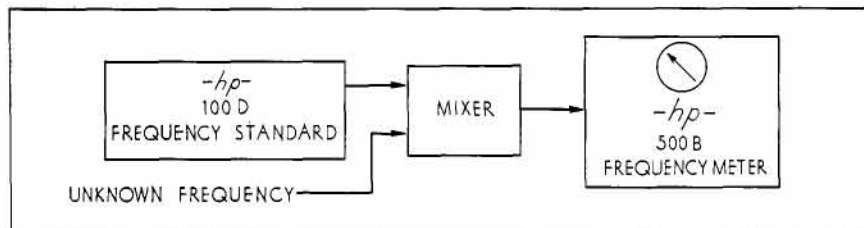

Figure 2. Typical setup for measuring deviation of unknown frequency from standard frequency.

over a wide range of 300 rpm to 3,000,000 rpm.

Tachometer Indicators

Proper transducers are the first step in tachometry measurements. The next step involves the tachometer indicators which count the electrical pulses and display the counting information. The tachometry accuracy largely depends upon these tachometer indicators.

Hewlett-Packard makes two general types of tachometer indicators, frequency meters and frequency counters. The principal difference is that the frequency meters respond in proportion to the rate of input pulses, whereas the frequency counters directly count each input pulse. This means in practice, that whereas the frequency meters have the necessary accuracy for most industrial applications, the frequency counters are able to give a high degree of precision and are suitable for not only ordinary measurements, but also the most exacting design applications.

Hewlett-Packard produces the following frequency meters: *-hp- 500B*, counting in cps or rps, *-hp- 500C*, counting in rpm.

These instruments will count at a rate of 60 - 6,000,000 rpm, and will give accuracy of better than $\pm 2\%$. For small differentials in readings or small changes in repetitive readings these instruments have even better accuracy.

Frequency Meter

-hp- 500B Electronic Frequency Meter (page 48) is a complete measuring instrument in its own right which can also be used to measure difference frequencies. This instrument provides direct meter indication of fre-

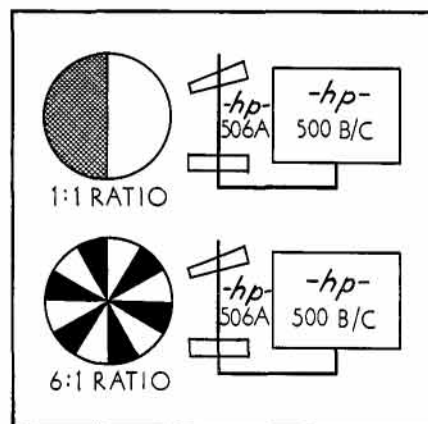

Figure 3. Typical setup for extending low-frequency range of *-hp- 500B/C* Electronic Tachometer Indicators.

quencies from 1 cps to 100 KC in nine convenient scale ranges. It is suitable for laboratory and production measurements at audio and supersonic frequencies.

-hp- 500B is particularly suited to crystal grinding work, where it can be used to measure frequency deviation from standard quickly and accurately. Similarly, in conjunction with *-hp- 100D* Frequency Standard and the *500B* quickly and accurately measures frequency deviation of the unknown from the standard frequency (Figure 2).

Tachometer Indicator

-hp- 500C Electronic Tachometer Indicator is a natural development from the *500B*. While the *500B* is calibrated to read in cycles or revolutions per second, the *500C* reads directly in revolutions per minute.

When used with *-hp- 506A* Optical Pickup it will indicate speeds from 300 rpm (5 rps) to 300,000 rpm (5,000 rps). Speeds lower than 300 rpm can be measured with the *-hp- 500C* Electronic Tachometer Indicator and *506A* by dividing the rotating shaft or disc into more than two segments. For example, a 6-black, 6-white segmentation (Figure 3) will give a multiplication factor of 6. Actual speed of rotation in this setup is the direct reading of *-hp- 500C* divided by the number of white or number of black segments—in this example 6. Speeds ranging from about 20 to 40,000 rpm can also be measured by the *500C* in conjunction with the *-hp- 508A/B* Tachometer Generator.

Frequency Counters

For the utmost precision and versatility in tachometry, as well as general frequency type measurements, Hewlett-Packard produces three electronic counters:

-hp- 521A Industrial Electronic Counter, which makes possible wide range frequency, speed and time interval measurements. It will count at the rate of 1 cps to 120 KC.

-hp- 522B Electronic Counter, which makes possible wide range frequency, period, and time interval measurements, making use of crystal controlled time base for superior accuracy. It will count at the rate of .00001 cps to 100 KC.

-hp- 524B Electronic Counter, although primarily a laboratory instrument, has tachometry applications when its supreme accu-

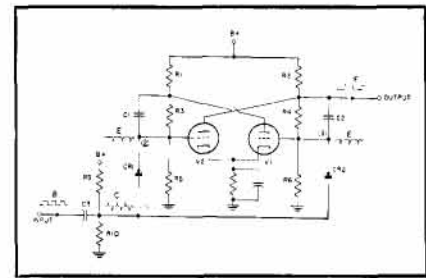

Figure 4. Basic binary scaler.

racy and frequency range are required. With plug-in units it will count at the rate of 0 cps to 220 MC.

In these instruments, frequency is measured by pulse counting techniques, with results being displayed automatically, instantly, and in direct-reading numerical form. The reading is complete even to an illuminated automatic decimal point.

The counting is performed with a bistable multivibrator or binary scaler (Figure 4). The binary will produce one output pulse for each of two pulses at the input. Cascading four of these basic units results in one output pulse for sixteen input pulses.

But because of the greater convenience of decimal over binary scaling, special circuitry is added in the counters to enable the four binaries to put out one pulse for each ten input pulses. This is the decimal scaling approach employed in all *-hp-* Electronic Counters.

Counter Details

Both *-hp- 522B* and *-hp- 524B* Electronic Counters contain a precision oscillator which may be readily standardized against transmissions from Station WWV (Figure 1). For its time base the *-hp- 521A* Industrial Counter makes novel use of the standard 60-cycle line frequency which is universally available and normally accurate to 0.1%.

The simplicity of operation of Hewlett-Packard Electronic Counters in making frequency measurements is worthy of special mention. When an unknown is connected to the input terminals, the measured frequency is displayed instantly on illuminated scales and meters. This extreme simplicity of operation means the counters can be used by non-technical personnel with virtually no special instruction.

For further information on the capabilities and operation of *-hp-* Counters, please see page 53.

hp 100D SECONDARY FREQUENCY STANDARD



Advantages:

- Sine or rectangular waves
- 100 μ sec time markers
- Built-in oscilloscope
- Stability 1/1,000,000
- Low output impedance
- Controlled frequencies: 100 KC, 10 KC,
1 KC, 100 cps, 10 cps

Use It To:

- Perform most functions of expensive primary standards
- Establish standard frequencies
- Calibrate audio oscillators
- Calibrate supersonic or rf oscillators
- Check transmitter stability
- Check oscillator stability
- Measure short time intervals
- Provide time standard

Generates 5 Standard Frequencies for Swift, Sure Comparison

TODAY, nearly every electronics or communication establishment is confronted with the problem of obtaining standardized, precisely-known frequencies for use in determining unknown frequencies. Until recently, this problem has been solved by the use of elaborate and expensive primary frequency standards whose frequency is established by constant checks against standard time. However, the reliability and convenience of standardizing with Bureau of Standards transmissions (Station WWV) have resulted in the recent widespread use of more economical secondary standards as a source of accurate frequencies.

The Model 100D Secondary Frequency Standard has been developed with this trend in mind. The instrument may be standardized against Station WWV without the use of additional equipment other than a standard audio oscillator and a communications receiver. Thus the instrument provides most of the advantages of a primary standard, at much lower cost.

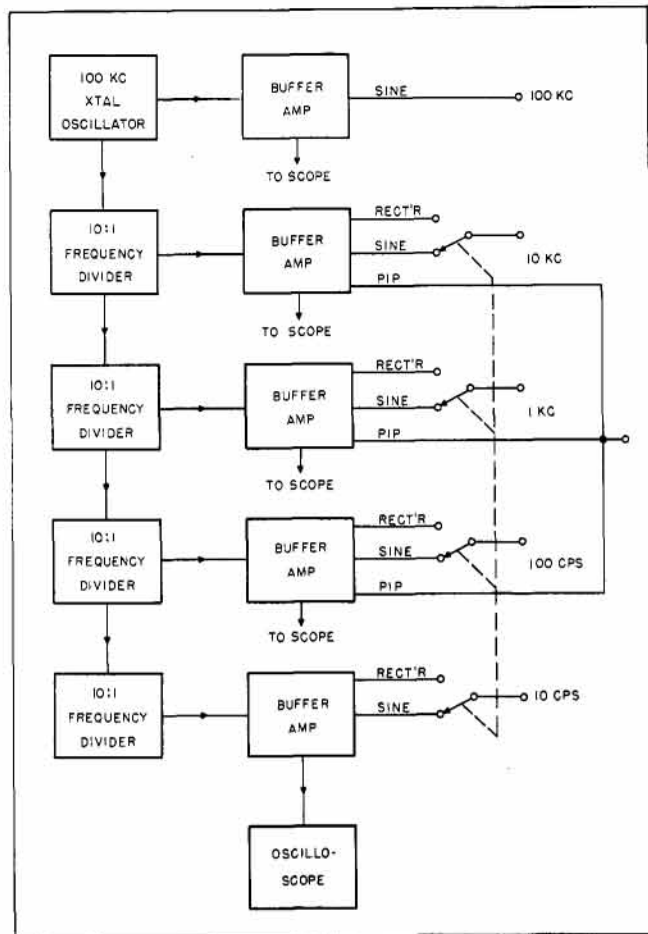

Figure 1. Block diagram of circuit, Model 100D.

Sine or Rectangular Frequencies

Five sinusoidal standard frequencies—100 KC, 10 KC, 1 KC, 100 cps and 10 cps—are generated by Model 100D. In addition, the equipment also generates rectangular waves at all the above frequencies except 100 KC. Harmonics as high as 5 MC can be obtained from these rectangular waves for measurement purposes.

In addition, the instrument also provides marker pips at 100, 1,000 and 10,000 microsecond intervals. (See Figure 2.) A self-contained oscilloscope further contributes to convenience in standardizing the instrument. It provides a visual check of the division ratio and is useful in calibrating audio oscillators and other supersonic or rf equipment by means of Lissajous figures.

Circuit Description

The block diagram in Figure 1 shows the circuit arrangement of this Secondary Frequency Standard. A crystal-controlled oscillator operating at 100 KC controls the stability of all frequencies generated by the instrument. The frequencies of 10 KC, 1 KC, 100 cps and 10 cps are obtained from four 10:1 cascaded frequency dividers driven by the 100 KC crystal-controlled oscillator. Each divider operates its own isolating amplifier so that all sine waves or rectangular waves generated are available for external use simultaneously.

Crystal Oscillator

The oscillator circuit employs a very low-temperature coefficient crystal. Housing for the crystal is a double-chamber oven, temperature controlled by a mercury thermostat having a differential of 0.1°C. Control of the oven and stability of the crystal are such that an over-all accuracy within approximately 2/1,000,000 is provided over an interval of one week.

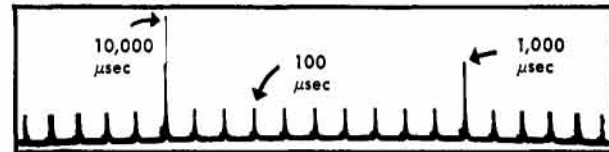

Figure 2. Timing comb, -hp- Model 100D.

Specifications

Accuracy: About 2 parts per million per week, at normal room temperatures.

Stability: About 1 part per million over short intervals.

Panel Control: Panel trimmer allows oscillator frequency to be varied over a range of approximately 0.5 cps for correction purposes.

Voltage Output: Sinusoidal output 5 volts into 5,000 ohms or higher load. Internal impedance approximately 200 ohms.

Distortion: Less than 4% when operating into 5,000 ohms or higher load.

Frequency Output: Controlled frequencies: 100 KC, 10 KC, 1 KC, 100 cps, 10 cps. Sine or rectangular waves.

Marker Pips: Generated at intervals of 100 μsec. A pip of double amplitude is generated every 1,000 μsec; and a pip of triple amplitude every 10,000 μsec.

Oscilloscope: Integral with circuit. Establishes 10:1 Lissajous figures to show division ratio. May be used independently of standard.

Frequency Shifting Circuit: Panel push-button lowers oscillator frequency by approximately 1 cps at 100 KC (50 cps at 5 MC) to aid in frequency measurements.

Rectangular Waves: 4 waves, generated corresponding to 10 KC, 1 KC, 100 cps and 10 cps. Harmonics up to 5 MC obtainable from 10 KC waves. Corresponding harmonics obtainable from other waves.

Power: 115/230 v ± 10%, 50/1,000 cps, 150 watts.

Dimensions: Cabinet Mount: 20¾" wide, 12½" high, 14¾" deep. Rack Mount: 19" wide, 10½" high, 13⅝" deep. Also can be used with -hp- AC-17 End Frames.

Weight: Net 44 lbs. Shipping 102 lbs. (cabinet mount).

Accessories Available: AC-16A/B Cable Assembly.

Data subject to change without notice.

hp 500B ELECTRONIC FREQUENCY METER



Advantages:

- Wide frequency range
- Accurate
- Good sensitivity
- Accuracy independent of line voltage changes and tube characteristics
- Nine convenient scale ranges
- Expanded scale feature
- Output pulse provision

Use It To Measure:

- Beat frequency between two rf signals
- Crystal frequency deviation
- Audio frequencies
- Speed of rotating machinery
- Oscillator stability

Measures Frequency of ac Voltages as High as 100 KC

THE *-hp-* Model 500B directly measures the frequency of an alternating voltage from 1 cps to 100 KC. It is suitable for laboratory and production measurements of audio and supersonic frequencies, or for direct tachometry measurements (with a transducer such as *-hp-* 506A or 508A/B). For added convenience in tachometry measurements this instrument is available with calibration in rpm as *-hp-* Model 500C.

The *-hp-* Models 500B/C are completely redesigned versions of the *-hp-* 500A and *-hp-* 505A/B so as to provide broader frequency coverage and increased versatility of use. To achieve these results an entire new circuit has been designed. The frequency meter consists of a wide band amplifier, a schmitt trigger, a constant current source, a current switching tube, a phantastron and an output meter. The schmitt trigger is used to trigger the current switching tube in accordance with the rate of input pulses. A phantastron controls the "on" time of the switching tube during which time the plate current is directed to the out-

put meter. The circuit is designed so that each pulse of charging current has the same average value, making the meter reading proportional to the number of pulses per second, and hence proportional to the frequency of the input signal.

Independent of Signal Voltage

The reading is independent of the input voltage waveform. The regulated current source makes the reading independent of variations in input signal voltage, line voltage, and vacuum tube characteristics. The frequency meter will count sine waves, square waves or pulses and will indicate the average frequency of random events. Provision is made for checking the calibration against power line frequency. Provision is also made to operate an Esterline-Angus 1 ma recorder for a continuous frequency record.

Expanded Scale Feature

For extreme ease of readability the -hp- 500 Frequency Meter contains an expanded scale feature which permits any 10% or 30% portion of a selected range to be expanded to full meter scale. This feature is present on all but the two lowest ranges.

In practice, this means that for repetitive or differential type measurements the meter can be set for expanded scale readings and left in this position to better observe small fluctuations in readings. The expanded scale permits precise accuracy in the measurement of small frequency changes or differential frequencies.

Strobe Output

A pulse output synchronous with each input pulse is made available on the front panel. This output provides uniform pulses which can be used to sync a stroboscope or an oscilloscope.

The output pulse could be used, for example, in conjunction with a stroboscope for observation of the various parts of a gear train checking for the presence of vibration or torsion.

Specifications

-hp- 500B

Frequency Range: 1 cps to 100 KC. Nine ranges with full scale values of 10, 30, 100, and 300 cps; 1, 3, 10, 30, and 100 KC.

Expanded Scale: Allows any 10% or 30% portion of a selected range to be expanded to full meter scale. (Not present on bottom two ranges.)

Input Voltage: Sensitivity: 0.2 volts rms minimum for sine waves, 0.1 volt peak minimum for pulses. Maximum: 250 v peak. Sensitivity control on front panel to reduce threshold sensitivity.

Input Impedance: Approximately 1 megohm shunted by 40 μ f. BNC connector for input.

Accuracy: Better than $\pm 2\%$ full scale value of range selector setting. Line voltage variations of nominal $\pm 10\%$ affect reading less than $\pm 1/2\%$ full scale.

Calibration Control: Allows calibration of internal constant current source and check against 60 cps line frequency.

Recorder Output: Phone jack on panel for connection to 1 ma, 1400 ohm ± 100 ohm Esterline-Angus Automatic Recorder.

Pulse Output: To trigger stroboscope, etc. in synchronism with input signal.

Photocell Input: Phone jack on panel provides bias for Type 1P41 Phototube. Allows direct connection of -hp- 506A Optical Tachometer.

Power: 115/230 v $\pm 10\%$, 50/1,000 cps, 65 watts.

Dimensions: Cabinet Mount: 7 $\frac{3}{8}$ " wide, 11 $\frac{1}{2}$ " high, 12 $\frac{1}{4}$ " deep.

Weight: Net 17 lbs. Shipping 35 lbs.

Accessories Available: -hp- 506A Optical Tachometer Pickup. -hp- 508A/B Tachometer Generator. Accessory meter 500B-95A \$21.00.

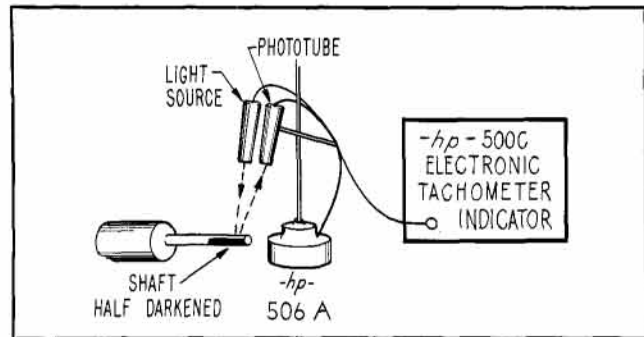

Electronic Tachometer Indicator

-hp- Model 500C Electronic Tachometer Indicator is similar to the 500B Electronic Frequency Meter except for calibration. By calibrating the output meter in revolutions per minute, Model 500C becomes an electronic tachometer, capable of counting speeds or revolutions over a wide range, from about 60 rpm to 6,000,000 rpm. In conjunction with -hp- 508A/B Tachometer Generators, this instrument accurately measures speeds from 30 to 30,000 rpm. The instrument is capable of measuring very high speeds of moving parts which have small energy or which for other mechanical reasons cannot be mechanically connected to any measuring device. The danger of fractional or multiple errors, inherent in other measuring methods, is eliminated.

Specifications

-hp- 500C

Circuit and Construction same as -hp- 500B except for meter calibration.

Speed Range: 60 rpm to 6,000,000 in nine ranges.

Data subject to change without notice.

hp 335E VHF-UHF TV MONITOR

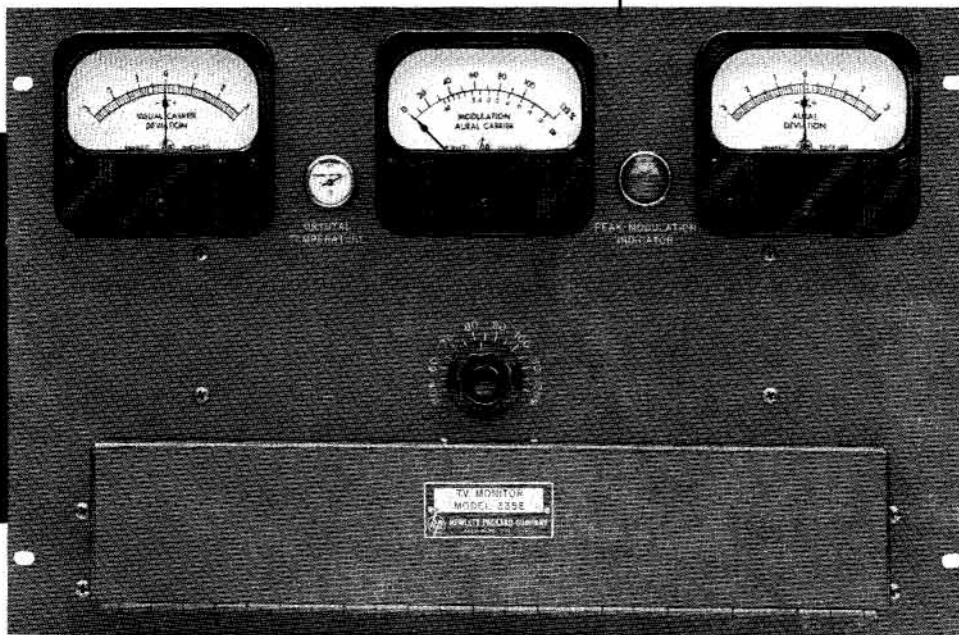

Advantages:

- Covers all Channels 2 to 83
- Monitors visual, aural frequencies or % aural modulation
- Use now for monochrome; later for color
- Reads inter-carrier separation directly
- Only 12 $\frac{1}{4}$ " high; rack mounted
- High stability, accuracy
- Continuous, precise indication without adjustment
- Slide mounting for convenient access

Uses:

- Monitor TV broadcast frequencies
- Monitor percentage modulation of aural carrier
- Maintain transmitter within F.C.C. specifications
- Make readings of inter-carrier separation

Continuous TV Monitoring Without Adjustment

MODEL 335E is the most compact and inexpensive quality TV Monitor offered. Yet this versatile instrument performs every important TV carrier monitoring function continuously and without adjustment, and with the dependability and accuracy you expect from Hewlett-Packard. The instrument is equally useful in monochrome or color broadcasting; you can buy it now for black-and-white monitoring and later use the same low-cost monitor—without modification—when you convert to color.

In addition to continuous, precise indication of visual and aural frequency deviation and percentage of aural modulation, Model 335E shows inter-carrier separation directly. No calculation is required.

Carefully engineered crystal reference oscillators provide accuracy in excess of F.C.C. requirements for all channels. Because discriminator accuracy does not depend on a tuned circuit, no time-consuming adjustments are required during operation. It is never necessary to reset carrier level or realign circuits. Proper operation of the monitor can be checked conveniently by controls located behind the hinged panel cover.

The three panel meters monitor visual and aural carrier frequency and percent modulation of the aural carrier with

100% modulation equal to 25 KC deviation. A peak modulation indicator lamp is included as standard equipment; the instrument also has provision for remote indicating meters, remote peak modulation indicating lamp, and a demodulated signal for measuring FM and AM noise levels, frequency response and distortion of the aural transmitter.

-hp- 335E is particularly designed for long years of trouble-free operation. Highest quality components and construction are used throughout. A new chassis design increases accessibility of components and makes possible cool operation. The chassis is mounted on slides for easy withdrawal from the rack.

The instrument includes a front panel crystal temperature indicator and illuminated meter faces. It fits a standard relay rack, can be color finished to match your transmitter installation, and is adjusted for your specific channel and offset.

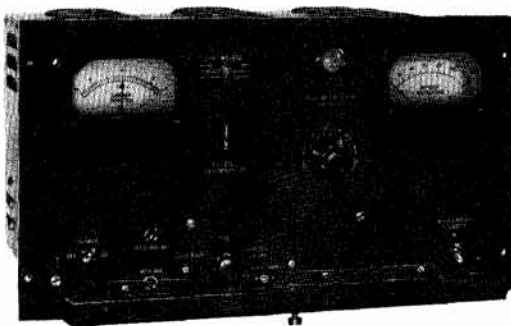

-hp- 335B FM Monitor

This Monitor is similar in most respects to -hp- 335E, but is intended for use in FM broadcast monitoring only. Two panel meters give continuous and accurate indication of aural carrier deviation and percent modulation.

Specifications

-hp- 335B

Frequency Range: 88 to 108 MC.

Deviation Range: +3 KC to -3 KC mean frequency deviation.

Accuracy: Deviation indicator accuracy is better than $\pm 1,000$ cps ($\pm 0.001\%$).
Modulation meter accuracy within 5% full scale.

Modulation Range: Meter reads full scale on modulation swings of 100 KC. Scale calibrated to 100% at 75 KC, 133% at 100 KC.

Power: 115 v ± 10 v, 50/60 cps, 165 watts.

Dimensions: Available only for rack mounting: 19" wide, 10 $\frac{1}{2}$ " high, 14 $\frac{1}{2}$ " deep.

Weight: Net 45 lbs. Shipping 95 lbs.

Accessories Furnished: 1 M-72 Power Cord; 1 38-66 Straight AN Connector; 1 38-67 Elbow AN Connector.

-hp- 335E

Aural Frequency Monitor:

Deviation Range: +3 KC to -3 KC mean frequency deviation.

Accuracy: Channel 2-6 ± 500 cps for 90 days.
7-13 ± 500 cps for 45 days.
14-83 ± 500 cps for 14 days.

Aural Modulation Meter:

Modulation Range: Meter reads full scale on modulation swing of 33.3 KC. Scale calibrated to 100% at 25 KC swing; 133% at 33.3 KC swing. Also includes db scale (0 db = 100%).

Accuracy: Within 5% of indicated modulation percentage over entire scale.

Meter Characteristics: Meter damped in accordance F.C.C. requirements. Reads peak value of modulation peak of duration between 40 and 90 milliseconds. Meter returns from full reading to 10% of full value within 500 to 800 milliseconds.

Frequency Response: Flat within ± 0.5 db from 50 to 15,000 cps.

Modulation Peak Indicator:

Peak Flash Range: From 50% to 120% modulation (25 KC = 100%).

Visual Frequency Monitor:

Deviation Range: +3 KC to -3 KC mean frequency deviation.

Accuracy: Channel 2-6 ± 500 cps for 90 days.
7-13 ± 500 cps for 45 days.
14-83 ± 500 cps for 14 days.

Inter-Carrier Spacing: Directly measured, accuracy ± 500 cps for 6 months.

Audio Output:

Frequency Range: 50 to 15,000 cps. Response flat within ± 0.5 db. Equipped with standard 75 microsecond de-emphasis circuit.

High Impedance Output: 10 volts into 100,000 ohms at 100% modulation at low frequencies. Distortion less than 0.25% at 100% modulation. Residual noise at least 65 db below output level corresponding to 100% modulation at low frequencies.

Monitoring Output: 1 milliwatt into 600 ohms, balanced, at 100% modulation, at low frequencies.

General:

Frequency Range: Channels 2 to 83 inclusive, including offset channels.

RF Power Required: Less than 1 watt. Separate type N connectors provided for aural and visual inputs.

Ambient Operating Temperature: 45°C maximum.

External Meter Indication: External meter indication available for aural carrier deviation, visual carrier deviation, aural modulation percentage and peak indication. BNC connectors provided. Use of external meters does not affect operation of panel meters.

Power: 115 v ± 10 v, 50/60 cps, 180 watts.

Dimensions: Available only for rack mounting: 19" wide, 12 $\frac{1}{2}$ " high, 13" deep.

Weight: Net 67 lbs. Shipping 107 lbs.

Accessories Furnished: 1 M-72 Power Cord; 2 38-74 UG21B/U AN Connectors; 3 Dummy Meter Resistors.

Accessories Available: 335E-95A External Aural Deviation Meter Assembly; 335E-95C External Visual Carrier Deviation Meter Assembly; 335E-95B External Aural Modulation Percentage Meter Assembly.

Data subject to change without notice.

hp TRANSDUCERS

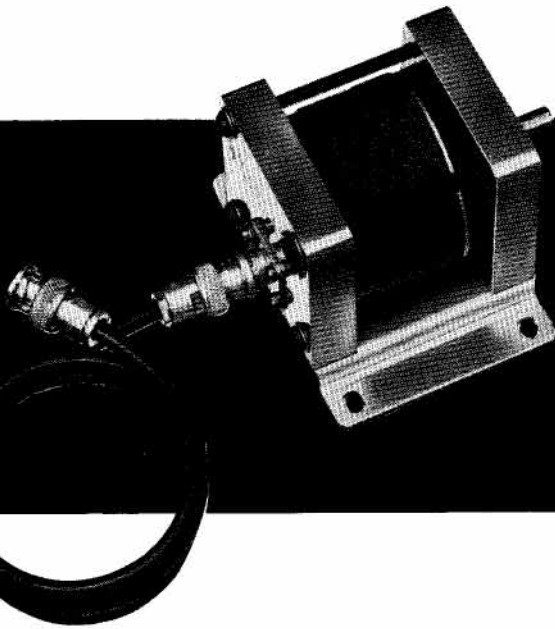

-hp- 508A/B Tachometer Generators

Models 508A/B Tachometer Generators are rotational speed transducers for use with electronic counters or frequency meters in making direct-reading rpm measurements from 15 to 40,000 rpm. They are particularly designed for operation with -hp- 521A, 522B and 524B Electronic Counters, -hp- 500B Electronic Frequency Meter and -hp- 500C Electronic Tachometer Indicator.

The 508A Tachometer Generator produces 60 cps of output frequency per shaft revolution. Thus when it is connected to an indicating instrument calibrated in cps, speeds are automatically recorded in rpm. The relationship between output voltage and shaft speed is virtually linear up to 5,000 rpm, making practical oscilloscope presentation of the shaft speed as a function of time for analyzing clutches, brakes or acceleration rates.

-hp- 508B is identical with -hp- 508A except that it produces 100 cycles of output frequency per revolution.

Specifications

Shaft Speed Range: 15 to 40,000 rpm.

Output Frequency: -hp- 508A: 60 cycles per revolution.
-hp- 508B: 100 cycles per revolution.

Output Voltage: Increases approx. linearly to 5,000 rpm, decreases thereafter to 40,000 rpm. Typical values: 0.2 v rms at 15 rpm, 1 v at 100, 10 v at 5,000 and 1 v at 40,000 rpm.

Drive Shaft: $\frac{1}{4}$ " diameter; projects $19/32$ ".

Torque: Approximately $\frac{1}{4}$ in. —oz. at 200 rpm; $\frac{1}{2}$ in. —oz. at 1,500 rpm.

Peak Starting Torque: Approximately 4 in. —oz.

Bearings: Permanently lubricated ball bearings.

Dimensions: $2\frac{5}{8}$ " high, $3\frac{1}{2}$ " wide, $3\frac{3}{4}$ " deep.

Accessories Furnished: 1 AC-16K Cable Assembly.

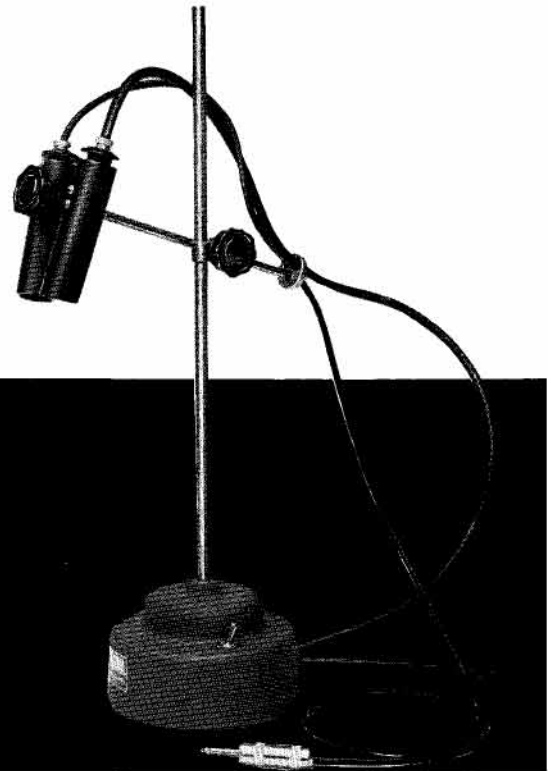

-hp- 506A Optical Tachometer Pickup

Model 506A is a versatile, flexible light source and pickup for use as a transducer with instruments such as -hp- 521A Industrial Electronic Counter, -hp- 500B Electronic Frequency Meter and -hp- 500C Electronic Tachometer Indicator. The instrument will measure very high speeds—from about 300 to 300,000 rpm—of moving parts which have small energy or cannot be connected mechanically to measuring devices.

Operation of the transducer is extremely simple. The part to be measured is prepared with alternate reflecting and absorptive surfaces. Light from the light source is interrupted by rotation of the part; the interrupted reflected light is picked up by the phototube and converted into electrical impulses.

Specifications

Nominal Shaft Speed Range: 300 to 300,000 rpm.

(Measurements of higher and lower speeds are possible by providing increased gain with an amplifier, such as -hp- 450A between the transducer and indicating instrument.)

Output Voltage: At least 1 v rms, 300 to 100,000 rpm (into 1 megohm or more impedance) with reflecting and absorbing surfaces $\frac{3}{4}$ " square.

Light Source: 21 candlepower, 6 volt automotive bulb.

Phototube: Type 1P41.

Phototube Bias: +70 to +90 volts dc (supplied by -hp- 500B/C, 521A.

Data subject to change without notice.

ELECTRONIC *hp* COUNTERS

THE development of pulse counter circuits has led to the manufacture of electronic counters capable of many measurements—particularly those involving frequency and time—that were not possible previously. New Hewlett-Packard electronic counters such as Models 524B and 522B offer the convenience of instantaneous, automatic reading, in direct numerical form, of unknown frequencies, time intervals or periods. They are engineered for utmost dependability and accuracy. Model 524B is perhaps the most broadly useful counter ever developed and incorporates the highest-speed counting circuit ever used in a commercial instrument of this type. *hp*-counters are designed for simple operation, and may be readily used by non-technical personnel.

A brief discussion of these counters in various types of measuring work appears below. Detailed descriptions appear on the following pages.

Frequency Measurements

The unknown frequency (f_x) to be measured by the counter is applied to the signal gate (Figure 1). The gate is held open for the precise length of time selected by the operator. The time base generator is a crystal oscillator with high stability. The pulses passed to the counter circuits during this period of time are totalized and displayed on the instrument. The highest frequency limit of *hp*-522B is 100 KC; the highest frequency of the 524B is 10 MC. With *hp*-525A/B Frequency Converters, the 524B is capable of measuring to 220 MC. Accuracy is determined by the crystal oscillator and a possible error of ± 1 count that is inherent with gate and counter-type of instrument.

Period Measurements

hp-counters are arranged so that they can measure period ($1/f_x$) directly (Figure 2). This is particularly important in frequency measurements below 300 cycles. When counting frequency below 300 cycles (Figure 3) the ± 1 count becomes a significant factor. In period measurement the unknown frequency (f_x) opens and closes the signal gate for 1 period or 10 periods and a standard frequency from the time base generator is applied to the counter circuits. Accuracy is then increased to 0.3% for a one-period measurement and

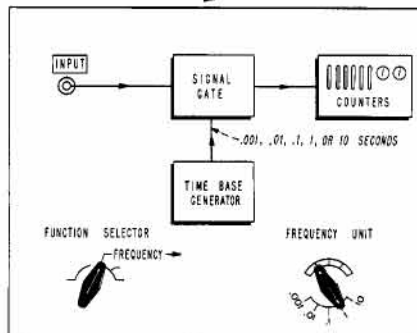

Figure 1. Frequency measurement circuitry in *hp*-electronic counters (*hp*-524B illustrated).

0.03% for 1 v rms signal over a ten-period average. Readings are displayed directly in microseconds, milliseconds or seconds.

Time Interval

Time interval measurements are similar to period measurements except that the point on the signal waveform or waveforms is adjustable. This adjustable threshold permits separate signals to be used as start and stop signals, or permits measure-

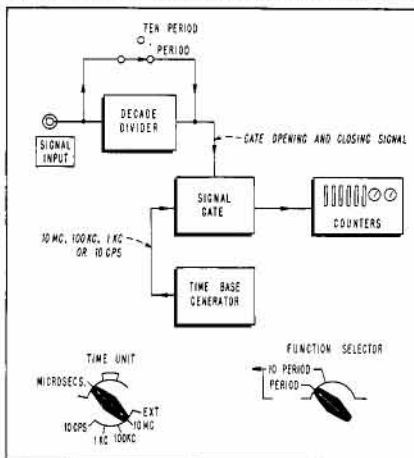

Figure 2. Period measurement circuitry in *hp*-electronic counters (*hp*-524B illustrated).

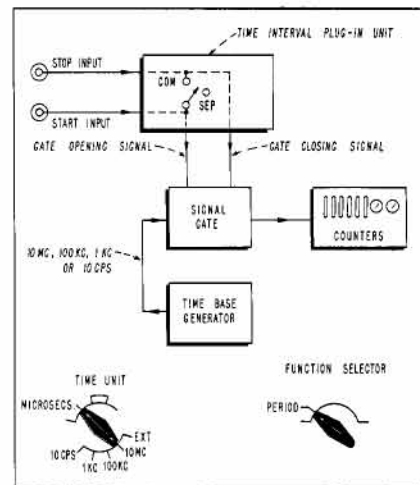

Figure 4. Time interval measurement circuitry in *hp*-electronic counters (*hp*-524B, 526B illustrated).

ments to be made from one part of a waveform to another part of the same waveform.

As in the case of period measurements, the input signal controls the opening and closing of the gate, while the standard frequencies are passed to the counters (Figure 4). Thus the accurate frequencies generated in the time base are used as units of time to measure the unknown interval in terms of microseconds, milliseconds, or seconds. Accuracy of this method is ± 1 count of the standard frequency counted. Time interval measurement is incorporated in the 522B and is available for the 524B.

Instrument Self Check

This feature enables the operator to determine if the counter is functioning properly. The frequency counted by the counter is 100 KC in the 522B and 100 KC or 10 MC in the 524B (Figure 5). The signal gate can be held open by any of the selected time bases. This allows the instrument to be checked at its maximum counting rate, and at each time base.

Miscellaneous Measurements

hp-electronic counters can also serve as a totalizer to indicate total number of random unit events. They will also measure time and frequency ratios, or serve as a secondary frequency standard. In conjunction with transducers such as *hp*-506A, 508A and 508B, tachometry measurements can be made with a high degree of accuracy.

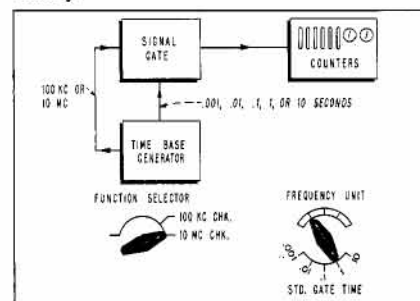

Figure 5. Self-check circuitry in *hp*-electronic counters (*hp*-524B illustrated).

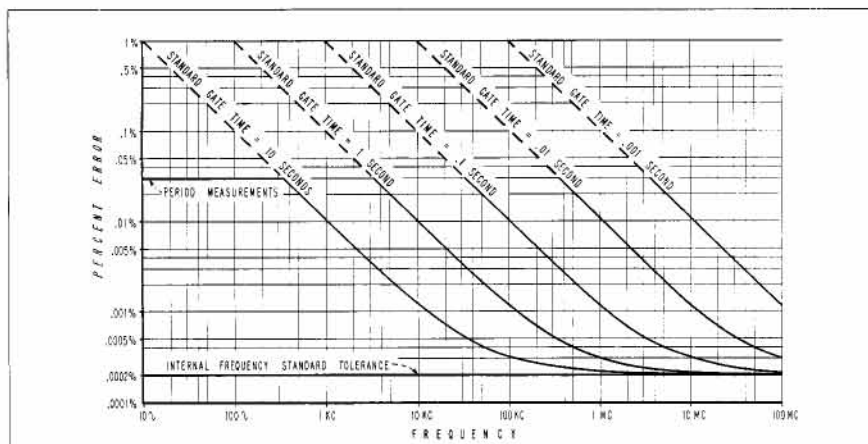

Figure 3. Possible error factor in frequency measurement (*hp*-524B, 525A).

hp 522B ELECTRONIC COUNTER



Advantages:

- Measures frequency, period, or time!
- Broad applicability
- High quality, low cost
- Accurate within 1/100,000
- Easily used by anyone
- Direct, automatic readings
- Bright, clear numerals
- Compact, weighs just 52 lbs.

Use To Measure:

Frequency:

- Production quantities
- Nuclear radiations
- Power line frequencies
- Rps and rpm
- Very low frequencies
- Oscillator stability
- Repetition rates
- Weight, pressure, temperature and acceleration—remotely

Time Interval Period:

- Elapsed time between impulses
- Pulse lengths
- Shutter speeds
- Projectile velocity
- Relay operating times
- Precise event timing
- Interval stability
- Frequency ratios
- Phase delay

Versatile, Low Cost Precision Counter

IN AN ever-increasing variety of manufacturing and research measurements, this all-purpose Hewlett-Packard counter has more operating speed, simplicity and accuracy at lower cost than any equipment ever offered.

The 522B counter offers the unique convenience of frequency, period *and* time interval measurement over a broad frequency range. The instrument is completely contained in a small, bench cabinet, and no extra-cost modification is required to perform all functions. Results are displayed instantly and automatically in direct reading form—either in cps, KC, seconds or milliseconds. Unskilled personnel can use the equipment immediately—no training or technical background is necessary. Bright, clear illumination of numbers is assured during display since counters use the new high-dependability *-hp-* AC-4A Decade Counters with etched circuitry (*see page 60*).

Operation

For frequency counting, *-hp-* 522B's range is 0.00001 cps to 100 KC. Counting is available over periods of 1/1,000, 1/100, 1/10, 1 and 10 seconds, or multiples of 10 seconds. Display time is variable at will, counts are automatically reset, and action is repetitive.

For period measurement, the unknown controls the opening and closing of the gate while the 522's decade counters record the number of cycles of an internal standard frequency. Period is presented in seconds, and milliseconds and by this method, frequency may be measured to 0.00001 cps.

Time interval is measured by a similar process except that gate time is governed by trigger pulses marking the beginning and end of the time interval to be examined. A threshold feature makes possible accurate measurement at each step of voltage (See Figure 1). Time intervals from 10 μ sec to 100,000 seconds (27.8 hours) can be measured; and again results are displayed directly in seconds or milliseconds. The count may be stopped or started on either positive or negative going waves at adjustable voltage levels from -100 to $+100$ volts.

Industrial Measurements

Many phenomena common to industrial research and manufacturing can be measured readily with *-hp-* counters using a simple transducer converting mechanical phenomena into electrical impulses. Such transducers include *-hp-* 508A/B Tachometer Generators. These transducers alone make possible a wide variety of measurements involving rotational motion (rpm of centrifuges, jet engines, superchargers, etc.). With suitable transducers linear motion such as projectile velocity can be analyzed to a fine degree of precision. For a more complete description of industrial use of 522B Counters, see Hewlett-Packard Journals, Vol. 4, No. 3 (Nov., 1952) and Vol. 5, Nos. 1-2 (Sept.-Oct., 1953).

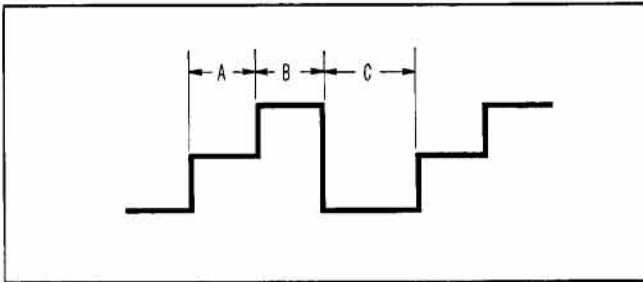

Figure 1. Threshold feature for time interval measurements permits measurement of duration of each step of voltage.

Specifications

-hp- 522B

Frequency Measurement:

Range: 10 cps to 100 KC.

Accuracy: ± 1 count \pm stability (see below).

Stability: 5 parts per million per week or better. May be standardized against WWV.

Registration: 5 places. Output pulse available to actuate trigger circuit for mechanical register to provide increased count capacity.

Input Requirements: 0.2 volt rms minimum. Input is direct-coupled.

Input Impedance: Approx. 1 megohm, 50 μ mf shunt.

Gate Time: .001, .01, .1, 1, 10 seconds. May be extended to any multiple of one or ten seconds by manual control.

Display Time: Variable from 0.1 to 10 seconds in steps of gate time selected. Display can be held indefinitely if desired.

Reads In: Cps or KC with the decimal point indicated.

Period Measurement:

Range: 0.00001 cps to 10 KC. Output pulse available to actuate trigger circuit for mechanical register to extend range to lower frequency.

Accuracy: $\pm .3\%$ \pm stability (see Frequency Measurement) for measurement of one period. Accuracy for

more than one period is $\pm 0.3\%$ divided by number of periods \pm stability.

Registration: Same as Frequency Measurement.

Input Requirements: 0.2 volt rms minimum. Direct-coupled input.

Input Impedance: Approx. 1 megohm, 50 μ mf shunt.

Gate Time: One or ten cycles of unknown frequency.

May be extended to any number of cycles of unknown frequency by manual control. This is limited to frequencies lower than 50 or 60 cps.

Std. Freq. Counted: 1, 10, 100 cps; 1, 10, 100 KC; external.

Display Time: Variable from 0.1 to 10 seconds in steps of the period being measured. Display can be held indefinitely if desired.

Reads In: Seconds or milliseconds with decimal point indicated.

Time Interval Measurement:

Range: 10 μ sec. to 100,000 seconds (27.8) hrs.).

Accuracy: ± 1 /std. freq. counted \pm stability (See Frequency Measurement).

Registration: Same as for Frequency Measurement.

Input Requirements: 1 volt peak minimum. Direct-coupled input.

Input Impedance: Approx. 250,000 ohms, 50 μ mf shunt.

Start and Stop: Independent or common channels.

Trigger Slope: Positive or negative on start and/or stop channels.

Trigger Amplitude: Continuously adjustable on both channels from -100 to $+100$ volts.

Std. Freq. Counted: 1, 10, 100 cps; 1, 10, 100 KC; external.

Display Time: Same as for Period Measurement.

Reads In: Seconds or milliseconds with the decimal point indicated.

General:

Features: (a) Operates with *-hp-* 508A Tachometer Generator.

(b) Operates with *-hp-* 520A Decade Scaler for high speed nuclear scaling, or directly for peak rates up to 100,000 per second.

(c) Measures frequency ratios.

(d) Makes time interval measurements with externally applied standard frequency.

(e) Operates as electronic stop watch with manual start, stop and reset.

(f) Operates as a secondary frequency standard providing precise rectangular output voltages at 1, 10, 100 cps; 1 and 10 KC and a 100 KC sine wave. Amplitude, approximately 1 volt peak.

Connectors: BNC.

Power: 115/230 v $\pm 10\%$, 50/60 cps, 210 watts.

Dimensions: Cabinet Mount: 20 $\frac{3}{4}$ " wide, 12 $\frac{1}{2}$ " high, 14 $\frac{1}{2}$ " deep. Rack Mount: 19" wide, 10 $\frac{1}{2}$ " high, 13 $\frac{1}{2}$ " deep. Also can be used with *-hp-* AC-17 End Frames.

Weight: Net 52 lbs. Shipping 96 lbs. (cabinet mount).

Accessories Furnished: 2 AC-16D Cable Assemblies.

Accessories Available: AC-16K Video Cable Assembly; 508A/B Tachometer.

Data subject to change without notice.

hp 524B ELECTRONIC COUNTER

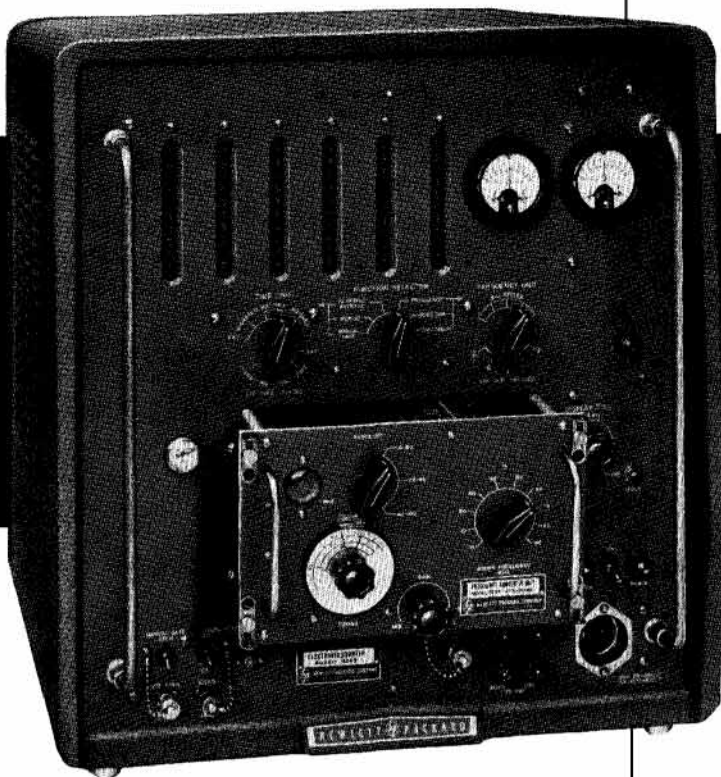

Advantages:

- Direct, instantaneous automatic readings
- Easily used by non-technical personnel
- Resolution 0.1 microseconds
- Accuracy $1/1,000,000 \pm 1$ count
- High sensitivity, high impedance
- Extreme reliability
- No calculation or interpolation
- Automatic decimal point
- Highest quality construction
- Compact; military design

Use For:

- Frequency measurements 10 cps to 220 MC
- Time interval measurements 1 μ sec to 100 days
- Period measurements 0 cps to 10 KC
- Standard frequency outputs of 10 cps, 1 KC, 100 KC, 10 MC
- Time and frequency ratios

Measures Frequency 10 cps to 220 MC* Time Interval 1 Microsecond to 100 Days

HERE is the revolutionary new Electronic Counter that gives you exactly the frequency, time interval or period measuring coverage you want. You buy the basic -hp- 524B Counter with selected -hp- 525 or 526 series Plug-In Units covering your exact present requirements; later you can add other inexpensive Plug-Ins to double or triple the usefulness of the instrument.

Great New Versatility

The compact, moderately priced 524B gives you more range, simplicity, usefulness and reliability than any *group* of instruments with comparable range ever offered. With this one all-purpose equipment, you measure transmitter and crystal oscillator frequencies, electrical, electronic and mechanical time intervals, pulse lengths and repetition rates or frequency drift. You make high accuracy ballistics time measurements or high resolution tachometry measurements. The instrument is also an ideal precision frequency standard, giving convenience and flexibility not found in the usual primary standards. It is simple to operate and readily used by non-technical personnel.

Basic Counter Details

In the basic 524B Counter (without Plug-In Units) frequency from 10 cps to 10 MC is read over 5 selected

*With -hp- 525A/B Frequency Converter.

periods—0.001, 0.01, 0.1, 1 and 10 seconds. Display time is variable at will, counts are automatically reset, and action is repetitive. Low frequencies (300 cps or below) are more accurately measured by determining the period of one cycle. Here the unknown frequency operates the gate and the internal standard frequency is applied to the counter. Thus the duration of a low frequency cycle is measured in time units. A 10-cycle sample may also be taken to improve accuracy. Results are measured instantly and automatically, and presented in direct reading form with automatic illuminated decimal point.

Counter Plug-in Units

Addition of -hp- 525 and 526 series Plug-In Units will extend the Counter's frequency range to 220 MC, provide increased sensitivity and a high impedance pickup probe, and make available uniquely flexible time interval circuits that may be started and stopped by any electrical impulse.

-hp- 525A Frequency Converter. This instrument extends the Counter's 10 MC direct-reading range in decade steps through 100 MC. It maintains Counter accuracy throughout the extended range. It provides additional amplification to increase video sensitivity to 0.1 volt throughout the Counter's basic 10 cps to 10 MC range. It contains

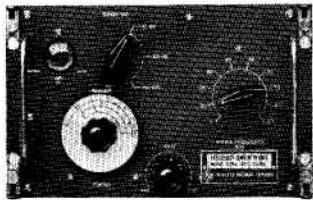

a tuned input circuit to simplify determining the correct frequency range and to reject harmonics and spurious signals.

-hp- 525B Frequency Converter. Similar to 525A, this unit extends the Counter's range from 100 MC to 220 MC in 10 MC steps, at the same time preserving the high accuracy of the basic counter. It maintains the same high sensitivity 0.1 volt minimum input throughout its range, and includes a wavemeter for determining the proper frequency decade range.



-hp- 526A Video Amplifier. This equipment increases the Counter's 10 cps-to-10 MC sensitivity to 10 millivolts for frequency measurement at low power levels. A special probe assembly simplifies remote pickup at high impedance levels. An oscilloscope output terminal enables monitoring at the input waveform visually.

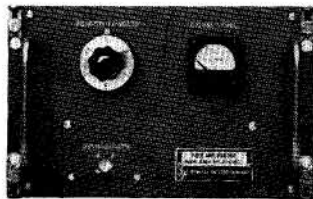

-hp- 526B Time Interval Unit. This instrument measures intervals from 1.0 μ sec to 100 days with accuracy of 0.1 μ sec \pm 0.001%. Intervals are read direct in seconds, milliseconds or microseconds. Start and stop triggering is performed in either common or separate channels, and may be accomplished through the use of positive or negative going waves. Trigger voltage levels are continuously adjustable from -192 to +192 volts.

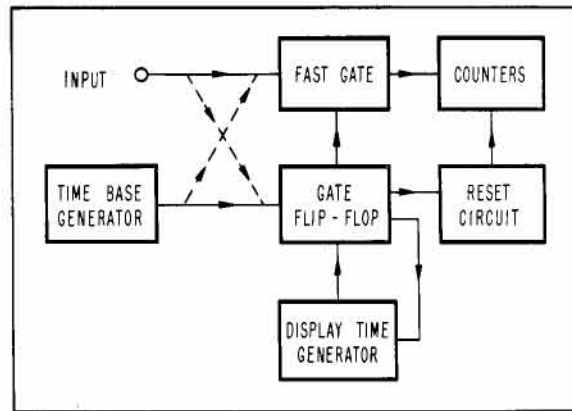
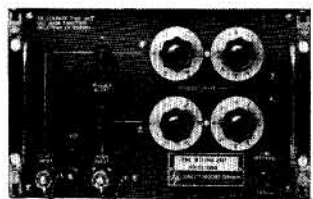

Figure 1. The block diagram illustrates the basic circuit arrangement of the 524B. The frequency to be measured is applied to an electronic gate. When the gate is open, the cycles are passed on to the counter circuits. When the gate is closed, the counters display the counted value. The operation of the gate is such that it is open for accurately-determined time intervals from 0.001 to 10 seconds. The counted value is then displayed directly in frequency. The time of opening and closing of the fast gate is controlled by the time base generator through the gate flip-flop. The flip-flop performs the actual operation of opening and closing the fast gate and also actuates the resetting circuit shortly before opening the gate. The resetting circuit clears the counting circuit preparatory to making the next count.

Specifications

-hp- 524B Electronic Counter

Basic Unit, for Frequency Measurements, 0 cps to 10 MC

Frequency Measurement: (without plug-in units)

Range: 10 cps to 10 MC.

Gate Time: 0.001, 0.01, 0.1, 1, 10 seconds or manual control.

Accuracy: ± 1 count \pm stability (see below).

Reads In: Kilocycles; decimal point automatically positioned.

Period Measurement: (without plug-in units)

Range: 0 cps to 10 KC.

Gate Time: 1 or 10 cycles of unknown.

Accuracy: $\pm 0.3\%$ (measurement one period).
 $\pm 0.03\%$ (ten-period average).

Standard Frequency Counted: 10 cps; 1 or 100 KC; 10 MC; or externally applied frequency.

Reads In: Seconds, milliseconds or microseconds; decimal point automatically positioned.

General:

Registration: 8 places (99,999,999 maximum counts).
First 6 places on neon lamp decades; last 2 on meters.

Stability: 1/1,000,000 short-term; 2/1,000,000 per week. May be standardized against WWV or used with external 100 KC primary standard for highest accuracy.

Display Time: Variable 0.1 to 10 seconds in steps of gate time selected. Display can be held indefinitely.

Output Frequencies: Secondary standard frequencies available at front panel: 10 cps, 1 KC rectangular; 100 KC positive pulse; 10 MC sine wave. (Stability as above.)

Self-Check: Panel control provides automatic count of internal standard 100 KC and 10 MC frequencies to

assure accuracy of gate and proper operation of counters.

Input Voltage: 1 volt rms minimum.

Input Impedance: Approx. 1 megohm, 40 $\mu\mu\text{f}$ shunt.

External Standard: 100 KC signal from external primary standard can be applied to unit for highest accuracy. 1 volt rms into 1 megohm, 40 $\mu\mu\text{f}$ shunt required.

Connectors: BNC Type.

Power: 115/230 v $\pm 10\%$, Cab. 50/60, Rack 50/1,000 cps, 500 watts.

Dimensions: Cabinet Mount: 20" wide, 21 $\frac{1}{8}$ " high, 23 $\frac{1}{2}$ " deep. Rack Mount: 19" wide, 19 $\frac{1}{4}$ " high, 17" deep.

Weight: Net 118 lbs. Shipping 206 lbs. (cabinet mount).

Accessories Furnished: 1 AC-16D Cable Assembly.
1 61B-16H Power Cable Assembly.

Accessories Available: AC-16K Video Cable Assembly; 524B-16P and 524B-16Q Test Cable Sets for -hp- 525/526 units.

-hp- 525A Frequency Converter Unit

for Frequency Measurement, 10 cps to 100 MC

Plugged Into -hp- 524B:

Range: As amplifier for counter, 10 cps to 10 MC. As converter for counter, 10 MC to 100 MC.

Accuracy: ± 1 cps \pm stability (See General).

Registration: 8 places; first place indicated on converter selector switch labeled 0, 10, 20 . . . 90; next 7 as indicated by counter.

Input Voltage: 0.1 volt rms minimum, 10 cps to 10 MC; 10 mv rms minimum, 10 MC to 100 MC.

Input Impedance: Approx. 1 megohm shunted by 40 $\mu\mu\text{f}$, 10 cps to 10 MC; approx. 50 ohms, 10 MC to 100 MC.

Level Control: Tuning eye aids frequency selection; indicates correct voltage level adjustment.

Dimensions: Storage Case: 12" wide, 9" high, 8" deep.

Weight: Net 10 lbs. Shipping 19 lbs.

-hp- 525B Frequency Converter Unit

for Frequency Measurement, 100 MC to 220 MC

Plugged Into -hp- 524B:

Range: 100 MC to 220 MC.

Accuracy: ± 1 cps \pm stability (See General).

Registration: 9 places; first two places indicated on converter selector switch labeled 100, 110, 120 . . . 210, next 7 indicated by counter.

Input Voltage: 0.1 volt rms minimum.

Input Impedance: Approximately 50 ohms.

Level Control: Same as 525A above.

Dimensions: Storage Case: 12" wide, 9" high, 8" deep.

Weight: Net 10 lbs. Shipping 19 lbs.

-hp- 526A Video Amplifier Unit

for Frequency Measurement, 10 cps to 10 MC high sensitivity

Plugged Into -hp- 524B:

Range: 10 cps to 10 MC.

Accuracy: Same as basic 524B Counter.

Input Voltage: 10 mv rms minimum.

Level Control: Meter indicates input signal level, correct voltage adjustment.

Output Terminal: BNC connector provides 10 times input voltage from 93-ohm source. Allows oscilloscope monitoring of input signal without loading circuit.

Reads In: Same as basic 524B Counter.

Dimensions: Storage Case: 12" wide, 9" high, 8" deep.

Weight: Net 10 lbs. Shipping 19 lbs.

Accessories Furnished: 1 526A-16A Probe.

-hp- 526B Time Interval Unit

for Time Interval Measurement

Plugged Into -hp- 524B:

Range: 1 μsec to 10^7 seconds.

Accuracy: ± 1 /standard frequency counted.
 \pm stability (See General).

Registration: Same as indicated under General.

Input Voltage: 1 volt peak minimum, direct-coupled input.

Input Impedance: Approx. 1 megohm, 40 $\mu\mu\text{f}$ shunt.

Start and Stop: Independent or common channels.

Trigger Slope: Positive or negative on start and/or stop channels.

Trigger Amplitude: Both channels continuously adjustable from -192 to $+192$ v.

Standard Frequency Counted: 10 cps, 1 or 100 KC; 10 MC or externally applied frequency.

Reads In: Seconds, milliseconds, or microseconds; decimal point automatically positioned.

Dimensions: Storage Case: 12" wide, 9" high, 8" deep.

Weight: Net 10 lbs. Shipping 19 lbs.

Accessories Furnished: 1 AC-16D Cable Assembly.

Data subject to change without notice.

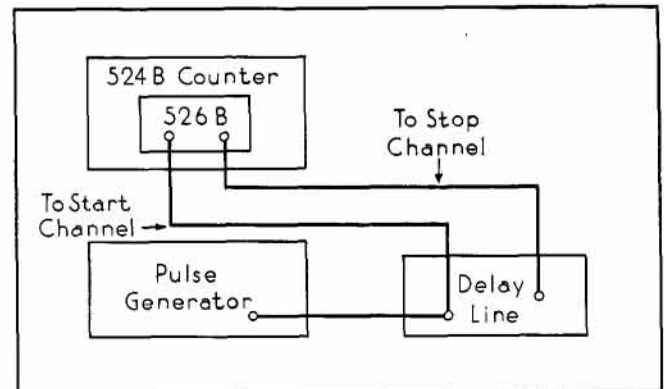

Figure 2. Measurement of time delay of a delay line with -hp- 524B Electronic Counter and -hp- 526B Time Interval Unit.

hp 521A INDUSTRIAL COUNTER



Versatile, Low Cost, Easy To Use— 1 cps to 120 KC

THIS new Hewlett-Packard counter fills the need for an easy to use, moderately priced instrument that will make specific industrial measurements heretofore possible only with much more elaborate equipment.

Model 521A measures frequency, speed, rpm and rps and counts events occurring at random within a selected period of time. With proper transducers converting mechanical into electrical phenomena, the instrument will also measure weight, pressure, temperature, acceleration and other quantities which can be related to frequency. The instrument is intended for use with such transducers as -hp- 506A Optical Tachometer Pickup and -hp- 508-A/B Tachometer Generators.

Model 521A reads in cycles per second, and also will indicate rpm and rps directly. Display of results is variable from 0.1 to 15 seconds or can be "held" indefinitely. Other useful features include a 60-cycle self check circuit to confirm accuracy of operation, three accessory power supplies of -120 v, +300 v dc, and 6.3 v ac, and a socket for connecting to a numerical printer.

Like other -hp- Counters, Model 521A uses -hp- AC-4A Decade Counters, the dependable, versatile new units described on the following page.

Specifications

Range: 1 cps to 120 KC.

Accuracy: ± 1 count \pm accuracy of 60 cycles timing frequency. (Usually 0.1% when timed by power line frequency.)

Registration: 4 places. Total count capacity 9,999.

Input Requirements: 0.2 volts rms.

Input Attenuator: Allows adjustment of sensitivity from 0.2 to 100 v rms to overcome noise.

Input Impedance: Approx. 1 megohm 50 μ f shunt.

Gate Time: 0.1 and 1 second.

Manual Gate: Controlled by "Open-Closed" switch or external contacts.

Display Time: Variable 0.1 to 15 seconds; or display can be held indefinitely.

Reads In: Cps or directly in rpm with proper pickup.

Self Check: Counts 60 cycles for any selected gate time.

Accessory Socket: Supplies -120 v dc +300 v dc and 6.3 v ac.

Photocell Input: Jack in back.

Printer Output: Socket in back.

Power Requirements: 115 v ± 10 v, 50/60 cps.

Size: 13 $\frac{7}{8}$ " high, 9 $\frac{3}{4}$ " wide, 13 $\frac{3}{8}$ " deep.

Weight: Net 25 lbs. Shipping 45 lbs.

Data subject to change without notice.



AC-4A DECADE COUNTERS

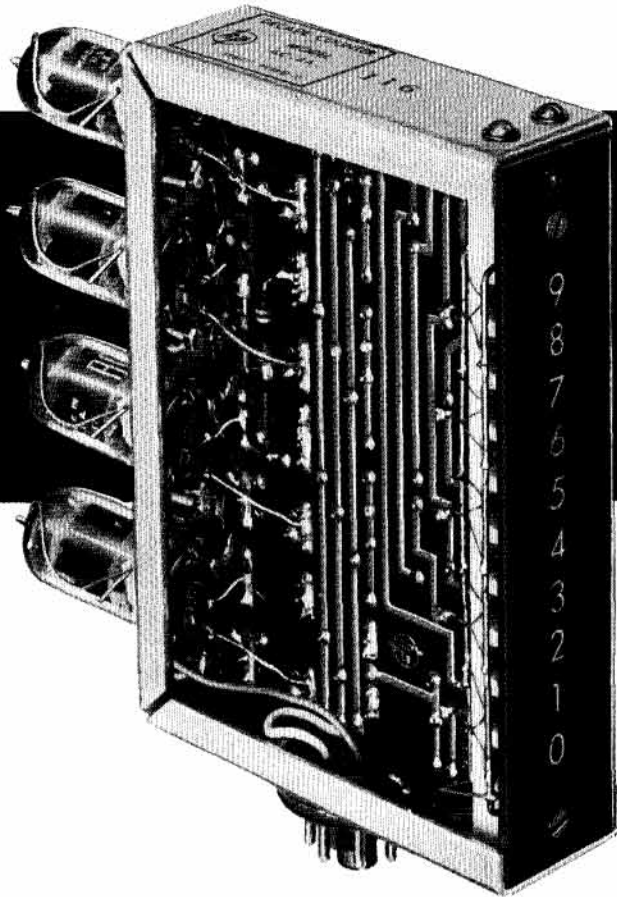

Specifications

Counting Rate: 120 KC maximum.

Double-Pulse Resolution: 5 microseconds.

Input Voltage: Approx. 80 v neg. pulse; 1 μ sec rise time.

Input Impedance: Approx. 15,000 ohms in series with 100 μ f during triggering.

Output Pulse: 80 v neg. to drive succeeding Counter.

Load Impedance: 300,000 ohms minimum (resistive) or 6,000 ohms in series with approx. 100 μ f (reactive).

Reset: (a) Reset to 0 by positive pulse or by opening external ground connection. (b) Reset to 9 by applying negative pulse.

Staircase Output Voltage: 135 volts at count of zero, 55 volts at count of nine in 10 steps. Internal resistance, 700 K. Operation unaffected by load on staircase.

Power Supply: Filament 6.3 v \pm 10% at 1.2 a; Plate 300 v \pm 10% at 15 ma (nominal).

Dimensions: 5 $\frac{5}{8}$ " deep x 1 $\frac{1}{4}$ " wide x 6 $\frac{1}{8}$ " high.

Mounting: Standard, requires octal socket.

Weight: 1 lb; shipping weight approx. 2 lbs.

Data subject to change without notice.

120 KC Counting Rate; Operates Recorders

THE unique etched circuit in -hp- AC-4A Decade Counters provides a new standard of reliability and makes possible dependable, high speed counting to 120 KC. The new plug-in units, engineered to fit all standard electronic counters, also provide a staircase output voltage proportional to count for operation of recorders or external equipment using coincidence detectors.

The new etched circuit is fully visible, accessible, clearly labeled and arranged diagrammatically for simplest servicing. Clean mechanical layout permits maximum ventilation, lower operating temperature and longer life. Optically engineered illuminated numerals are clear, bright, and easy to read under all external lighting conditions. The etched circuits give excellent balance and uniform incidental capacities for the high 120 KC counting rate. Resistors are premium quality 5%-tolerance units, coupling condensers are silver mica, and tubes are of the computer type.

-hp- AC-4A Counters are standard equipment in -hp- 521 and 524 series Electronic Counters, and recommended replacement in other standard electronic counters. They are also ideal for experimental or special applications and industrial installations.

hp 512A/B FREQUENCY CONVERTERS



Low Cost Converters Extend -hp- 524A Counter Range

HERE Hewlett-Packard offers two compact, low cost Frequency Converters that greatly extend the range and usefulness of your -hp- 524A Frequency Counter — and *Materially Increase Sensitivity Without Loss in Accuracy.*

-hp- 512A Frequency Converter increases the 524A's coverage from 10 MC to 100 MC in 10 decade steps. This converter also increases counter sensitivity for measurements down to 100 KC.

-hp- 512B Frequency Converter increases the Counter's coverage from 100 to 220 MC.

The accuracy provided by both instruments is identical with the basic counter accuracy, and the counter's crystal-controlled oscillator can, as when used separately, be continuously compared with Station WWV. The high sensitivity of both converters allows measurements to be made with a minimum of energy extracted from the circuit under test. In the 512A, a tuned amplifier eliminates unwanted frequency. In the 512B, a wavemeter provides accurate frequency selection. Both instruments include a tuning eye to indicate proper adjustment and input voltage level.

Both converters are available as compact portable bench instruments (illustrated), with 7" x 19" panels for rack mounting, or special mounting matching the 524A Counter.

Specifications -hp- 512A

- Frequency Range:** As converter: 10 MC to 100 MC. As amplifier: 100 KC to 10 MC.
- Input Voltage:** Requires 0.01 v minimum rms, 10 to 100 MC; 0.1 v, 100 KC to 10 MC. (On 50-ohm cable.)
- Standard Mixing Frequency:** Multiplies 100 KC output of -hp- 524A. (Accuracy 1/1,000,000 short term.)
- Output Voltage:** On minimum rated input, provides 1.4 volts rms (required voltage to operate 524A). Maximum output 4 volts rms.
- 10-Megacycle Output:** Provides special 10 MC output at same accuracy as standard 100 KC frequency applied to Converter; supplied at level of 1.5 v rms into 50 ohms. (For checking 524A operation.)
- Impedance Level:** Input and output, approx. 50 ohms, except input is approx. 1,000 ohms below 10 MC.
- Connectors:** Input and output, BNC type jacks.
- Power:** 115/230 v $\pm 10\%$, 50/1,000 cps, 65 watts.
- Dimensions:** Cabinet Mount: 7 $\frac{3}{4}$ " wide, 10 $\frac{3}{8}$ " high, 13 $\frac{3}{4}$ " deep. Rack Mount: 19" wide, 7" high, 12 $\frac{3}{4}$ " deep.
- Weight:** Net 18 lbs. Shipping 30 lbs. (cabinet mount).
- Accessories Furnished:** 1 AC-16D Cable Assembly; 2 AC-16K Video Cable Assemblies (512A); 2 AC-16E Video Cable Assemblies (512AR); 1 AC-67A Termination (50 ohm).
- Accessories Available:** AC-16K Video Cable Assembly; AC-44B Cabinet (for 512AR/BR).

-hp- 512B

Same as 512A except:

- Frequency Range:** As converter, 100 MC to 220 MC.
- Input Voltage:** Requires 0.2 volts minimum rms.
- Impedance Level:** Input and output approximately 50 ohms.

Data subject to change without notice.

hp 520A HIGH SPEED DECADE SCALER

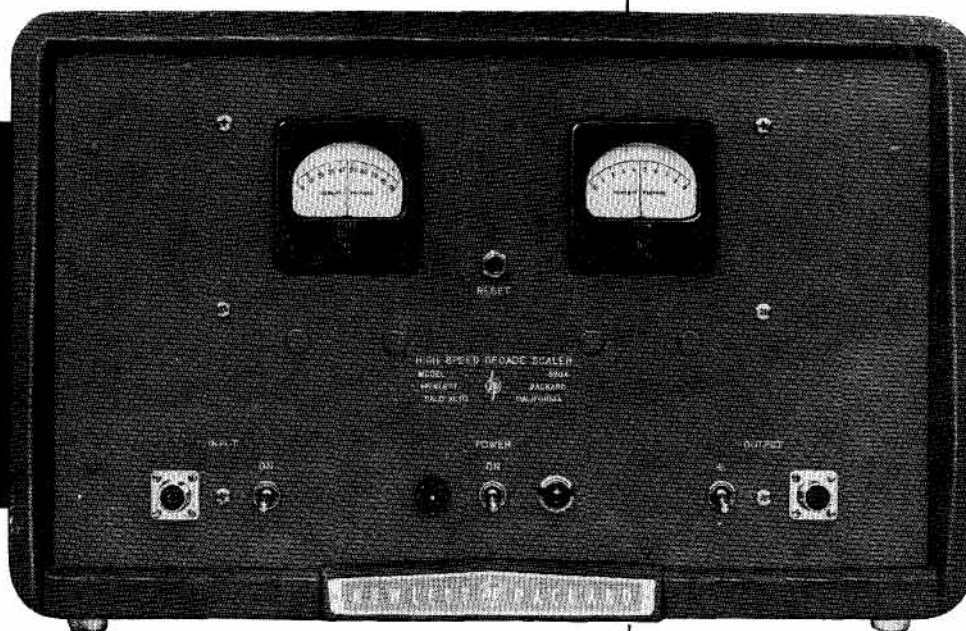

Specifications

- Required Input Polarity:** Positive pulses only.
- Amplitude:** 5 volts minimum. 30 volts maximum. 10 volts minimum for maximum counting rate.
- Required Rate of Rise:** 10 volts per μsec , minimum.
- Input Impedance:** 5,000 ohms.
- Resolving Time:** Two pulses, 5 to 30 volts peak: 0.1 μsec . Three pulses, 5 to 30 volts peak: 0.2 μsec 1st to 3rd pulse. Maximum continuous uniform rate: 10^7 counts/sec. No lower limit on counting rate.
- Counting Capacity:** 100 counts in two decades, count indicated by two meters (0-90 and 0-9). Pushbutton resets both meters to zero.
- Output:** Positive or negative triangular pulse, 50 volts amplitude and approximately 5 μsec wide at base. Rise time approximately 1 μsec .
- Output Impedance:** Operates into 5,000 ohm load, or higher.
- Connectors:** Uhf type.
- Power:** 115/230 v $\pm 10\%$, 50/60 cps, 200 watts.
- Dimensions:** Cabinet Mount: 20 $\frac{3}{4}$ " wide, 12 $\frac{1}{2}$ " high, 14 $\frac{3}{4}$ " deep. Rack Mount: 19" wide, 10 $\frac{1}{2}$ " high, 14" deep.
- Weight:** Net 51 lbs. Shipping 85 lbs. (cabinet mount).
- Accessories Available:** 38-75 uhf-BNC Adapters. AC-16K Video Cable Assembly.

Data subject to change without notice.

Quantitative Measurement of "Fast" Circuit Pulses

MODEL 520A makes possible quantitative measurement of extremely fast random or continuous occurrences. Its precise accuracy and high speed operation make possible easy measurement of "fast" circuit pulses or nuclear parameters. The instrument is an aperiodic counter which will record accurately continuous input rates of 10,000,000 counts per second, or will separate two sharp pulses spaced on 0.1 μsec apart.

The resolution capacity of the High Speed Decade Scaler makes it especially suitable for operation with scintillation counters. Since it provides an output pulse for every one hundred input pulses, its output may be connected to a conventional 100,000 pulse-per-second counter (such as -hp- 522B) to record large numbers of occurrences. This feature makes the -hp- 520A useful for measurement of frequencies up to 10 MC, in applications where the accuracy of the last two places is unimportant.

SIGNAL GENERATORS

A signal generator is an oscillator calibrated to provide output signals of precisely known frequency and power. Signal generators are essential to many different types of measurement, and in order to adequately serve their purpose, they must meet certain minimum requirements, viz: (1) accurate frequency calibration, (2) accurate and variable output, (3) constant output impedance, (4) varied modulation capabilities, (5) low leakage, (6) low harmonic content, and (7) freedom from spurious or incidental modulation.

Hewlett-Packard offers a complete easy-to-use line of vhf, uhf, and shf signal generators. There are nine precision instruments operating at frequencies between 10 and 11,000 MC, and a sweep oscillator operating from 7 to 10 KMC. Each generator incorporates every basic requirement listed above and is designed so that both frequency and power output are direct reading. This assures utmost convenience and accuracy for all kinds of measurements, including receiver sensitivity, selectivity or rejection, signal noise ratio, gain-bandwidth characteristics, conversion gain, antenna gain, transmission line characteristics; or for driving bridges, slotted lines, filter networks, etc.

-hp- signal generators can be divided

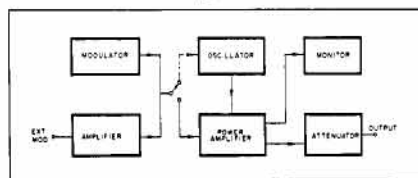

Figure 1. Block diagram of Model 608C/D and 612A Signal Generators.

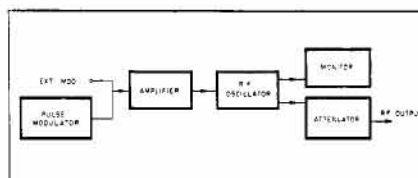

Figure 2. Block diagram of Model 614A, 616A, 618B and 620A Signal Generators.

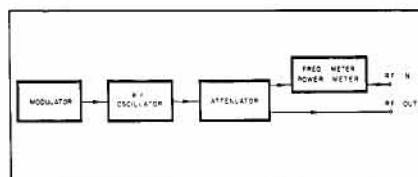

Figure 3. Block diagram of Model 623B, and 624C Signal Generators.

into three different groups according to their circuit design. The first group com-

prises Model 608C/D and 612A; the second group includes Models 614A, 616A, 618B and 620A, and the third group is composed of Models 623B and 624C. Table 1 shows the important characteristics of these units, and Figures 1, 2 and 3 show the basic circuit diagram of each group.

Oscillator Section

Tubes for the oscillator section of -hp- signal generators are carefully selected to cover the frequency range of each generator. Pencil triodes are used in -hp- Models 608C/D and 612A, while the higher frequency signal generators employ reflex klystrons. In Models 614A, 616A, 618B, 620A and 670HM, the frequency is varied by adjusting a shorting element that tunes the cavity resonator associated with the reflex klystron. On -hp- Models 623B and 624C tuning is achieved by mechanically distorting the cavity. This cavity is an inherent part of the reflex klystron used in these units.

Modulator Section

Hewlett-Packard generators, in addition to CW emission, also provide amplitude and frequency modulated output. The type of amplitude modulation (pulse, square-wave or sine wave) varies with each signal generator, and it is described in detail in Table 1.

-hp- 614A, 616A, 618B, and 624C Signal Generators include a pulser which is used for internal modulation. Considerable care has been taken to achieve a modulating pulse that has good waveform and does not undergo deterioration in the modulating system. Spurious FM, AM and harmonic content have been kept to a minimum by incorporating well regulated power supplies, good circuit design and excellent construction techniques.

In generators employing reflex klystrons (614A, 616A, 624C) internal FM is provided at power line (60 cycle) frequency with varying amplitude and phase. This feature is achieved by taking advantage of the fact that in reflex klystron oscillators, frequency is dependent on reflector voltage. For internal FM, -hp- 618B and 620A offer a saw-tooth sweep rate variable between 40 and 4,000 cps, and -hp- 623B has a 1,000 cps modulator.

External Modulation Techniques

There are many cases where it is desirable to modulate a signal generator with

Generator	Frequency Range (MC)	Frequency Accuracy	Calib. Output Range	Output Accuracy	Max. SWR of Output	Modulation	
						Internal	External
608C	10-480	± 1%	+ 13 to -127 dbm	± 1 db	1.2	Sine wave 400 and 1,000 cps	Sine wave, Pulse, Sq. Wave
608D	10-420	± 0.5%	+ 7 to -127 dbm	± 1 db	1.2	Sine wave 400 and 1,000 cps	Sine wave, Pulse, Sq. Wave
612A	450-1,200	± 1%	+ 7 to -127 dbm	± 1 db	1.2	Sine wave 400 and 1,000 cps	Sine wave, Pulse, Sq. Wave
614A	800-2,100	± 1%	0 to -127 dbm	± 1 db -10 to -127 dbm	1.6	Pulse, FM	Pulse, Sq. Wave
616A	1,800-4,000	± 1%	0 to -127 dbm	± 1 db -7 to -127 dbm	1.8	Pulse, FM	Pulse, Sq. Wave
618B	3,800-7,600	± 1%	0 to -127 dbm	± 2 db -7 to -127 dbm	2	Pulse, FM Sawtooth, Sq. Wave	Pulse, Sq. Wave, FM
620A	7,000-11,000	± 1%	-10 to -127 dbm	± 2 db -10 to -127 dbm	2	Pulse, FM Sawtooth Sq. Wave	Pulse, Sq. Wave, FM
623B	5,925-7,725	* ± 0.03%	0 to -70 dbm	± 2 db 0 to -70 dbm	2	FM	Pulse, Sq. Wave, FM
624C	8,500-10,000	* ± 0.03%	0 to -100 dbm	± 2 db -10 to -100 dbm	2	Pulse, FM	Pulse, Sq. Wave, FM
670HM	7,000-10,000		More than 10 mw			Provided by -hp- 717A	

*As set by wavemeter. With temperature correction, higher accuracy available.

Table 1. Characteristics of -hp- signal generators.

external signals. The type of modulation used must be applied to the generator in such a way as not to detract from the stability or accuracy of generator. Further, incidental or spurious modulation should not be introduced. Certain precautions, different for different signal generators, should be observed when applying external modulation.

When using *-hp-* Models 608C/D and 612A (which employ master oscillator power amplifier circuits) almost any type of modulation may be employed. In the *-hp-* Model 608C/D, all modulation is accomplished in the amplifier section, and any amplitude modulation (sine wave, square wave or pulse) can be employed as long as it is within the bandwidth limitation of the circuit. Because the amplifier section employs a grounded grid circuit, the power is not completely cut off between pulses. The reduction in power output between the time the pulse is on and off is better than 20 db at high frequencies and better than 40 db at low frequencies.

There is no provision for FM modulation in Models 608C/D and 612A signal generators.

In the *-hp-* Model 612A, provision is made for applying pulse and square wave modulation directly to either the oscillator or the amplifier section. When modulation is applied to the oscillator section the signal is completely cut off between pulses. It is advisable to apply only square waves or pulses for amplitude modulation on this oscillator. Other types of modulation should be applied to the amplifier section, the bandwidth limitation of which is 5 MC. The types of modulation employed (with due consideration to above restrictions) will not seriously affect the stability or spurious signal content of this generator.

Models 614A, 616A, 618B and 620A generators have similar requirements for external amplitude modulation. However, it is desirable to use pulse or square wave modulation of sufficient magnitude to completely cut off the generator between pulses. This is necessary to eliminate spurious signals and harmonics. If a square wave generator is not available,

a high voltage sine wave may be used. The use of this sine wave will tend to overload the modulator and the sine wave will become heavily clipped—thus applying an approximation of a square wave to the oscillator. Since the grid of the modulator tubes employ ac couplings, high level signals will tend to draw grid current and develop a clamp voltage on the grid of the tube. Damage to tubes is thus prevented. A typical set-up for applying modulation to these generators is shown in Figure 4. The amplitude of the modulating voltages should be approximately 50 volts.

Models 618B, 620A, 623B and 624C, in addition to external amplitude modulation, have provision for external frequency modulation. Modulation capability depends on the reflex klystrons in each in-

in the attenuator and output connectors. This type of output system has certain advantages which contribute greatly to the accuracy and usefulness of a signal generator. The monitoring circuit sets a reference calibration level and also serves as a continuous monitor on the oscillator level. Changes of oscillator level due to loading, etc., are immediately apparent. At any level the maximum available power from the generator can be determined quickly and accurately from monitor readings and attenuator settings. It is not necessary to return the output to a high level for monitoring.

-hp- generators are calibrated in terms of their maximum available power. Thus accurate measurements are easily obtained whether working into a standard 50-ohm load or into a load adjusted to match exactly with generator characteristics.

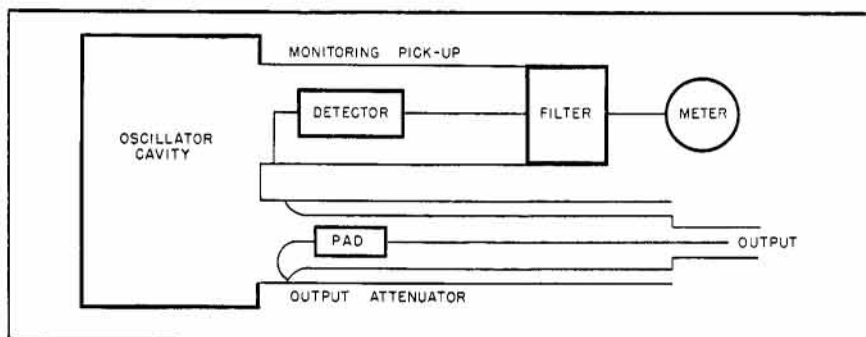

Figure 5: Monitoring and Attenuating system in *-hp-* signal generators.

dividual generator, and magnitude of the applied modulating voltage should be limited so that the reflector will not be swept into undesired oscillating modes.

Output Section

The output sections of *-hp-* generators are designed to achieve high monitor accuracy, high attenuator accuracy and to eliminate mismatch between generator and load.

In all *-hp-* generators power is monitored and measured at a fixed high power level as shown in Figure 5. After monitoring, power is attenuated down by a variable attenuator and then fed to the output terminals. Output impedance is held close to 50 ohms by utilizing pads

In Models 608C/D and 612A, a high order of monitor accuracy is achieved by employing a crystal detector at a low power level. Calibration is performed at a fixed level so monitor detector laws will not cause error in measurement. On other *-hp-* generators, accuracy is maintained through use of a thermistor bridge. In these instruments, drift compensating networks are employed to reduce zero drift and sensitivity to ambient temperature changes.

Attenuators in the output system are the waveguide-beyond-cutoff type, and operate on magnetic couplings for the lowest order mode. This type of attenuator is characterized by linear relation between the attenuation (in db) and displacement (in length units) of the coupling elements. The linear relationship holds except for approximately the first 7 db of attenuation. As long as the attenuator tubes are well below cut-off, the attenuation will be independent of frequencies and will be dependent only upon tube size and type of coupling employed. Attenuator tubes are accurately sized, and this, in conjunction with magnetic coupling assures that once the relation between attenuator movement and attenuation in

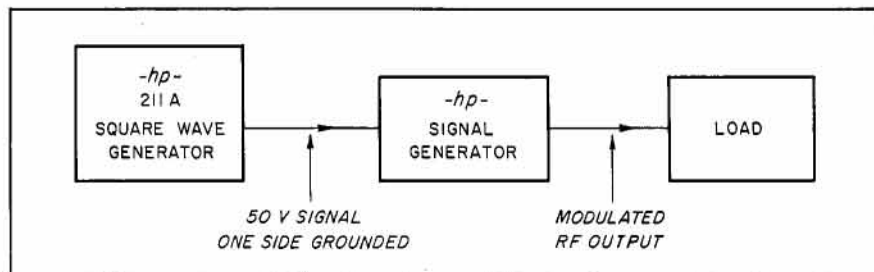

Figure 4: Typical set-up for applying modulation to *-hp-* signal generators.

db becomes linear, it will stay linear down to the lowest value desired.

Attenuator standardization is done at a point where the attenuation curve has become linear. On some instruments there may be a small departure from linearity at high output values, but the accuracy in all cases is better than ± 2 db, (at lower frequencies, better than ± 1 db). If greater accuracy is desired, calibration can be made or obtained from the factory.

Sources of Error

Harmonic Content: In *-hp*- signal generators every effort has been made to minimize harmonic content which is at least 20 db down. Nevertheless for some measurements (as for example, measurements involving filters, slotted lines or pre-selectors) even this residual harmonic content may cause error. Such errors may be eliminated by employing *-hp*- 360 low pass filters between the signal generators and equipment following the generator. (Figure 6)

Power Loss due to Mismatch: Another source of error in determining power output is mismatch between a signal generator output impedance and the instrument

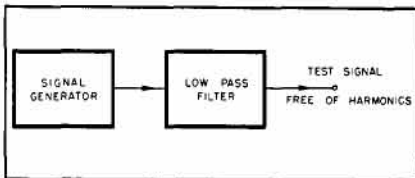

Figure 6: Typical set-up for eliminating harmonics.

following the generator. Hewlett-Packard generators have an output impedance of 50 ohms resistance which matches the nominal impedance of most cables and connectors. The deviation of output impedance from 50 ohms is designated Standing Wave Ratio (SWR) and it is less than 2:1 for all *-hp*- generators. With a knowledge of the value of SWR, the limits of the power loss can be calculated. It is necessary to know the phase of the reflection coefficient in order to determine the exact power loss.

A typical set-up for making measurement on signal generators is shown in

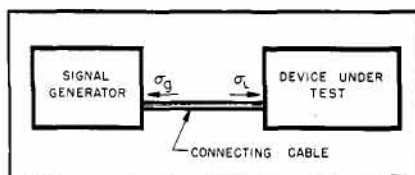

Figure 7: Typical set-up for making measurement on signal generators.

Figure 7. In order to determine the amount of error due to mismatch, the values of SWR of the signal generator and the load should be measured. Maximum and minimum power loss is obtained by substituting the values of SWR in the equation below:

P_{max} —the maximum power loss in db down is given by:

$$P_{max} = \left(20 \log \left[\sqrt{\sigma_g \sigma_L} + \frac{1}{\sqrt{\sigma_g \sigma_L}} \right] - 6 \right) \text{ db}$$

And P_{min} —the minimum power loss in db is given by:

$$P_{min} = \left(20 \log \left[\sqrt{\frac{\sigma_g}{\sigma_L}} + \sqrt{\frac{\sigma_L}{\sigma_g}} \right] - 6 \right) \text{ db}$$

Where σ_g = SWR of signal generator

Where σ_L = SWR of device under test

Note: These losses are with respect to the maximum available power output. (Calibration of the signal generator.)

These formulas can be drawn up in chart form as shown in Figure 8. As an example, let it be assumed that on a measurement the attenuator setting is -30 dbm; the SWR of the generator is 1; and the SWR of the load is 3. Then using the above formulas and chart, it can be shown that P_{max} equals 1.28 db, and P_{min} equals 0.52 db. Here it should be noted that because the generator is matched, the ambiguity of error is eliminated and power loss can be calculated exactly.

Assuming the same data as before with the exception that the generator has $1\frac{1}{2}$ to 1 SWR, it can be shown that P_{max} equals 2.28 db, and P_{min} equals 0.52 db. In this last example the power actually being delivered to the load lies somewhere

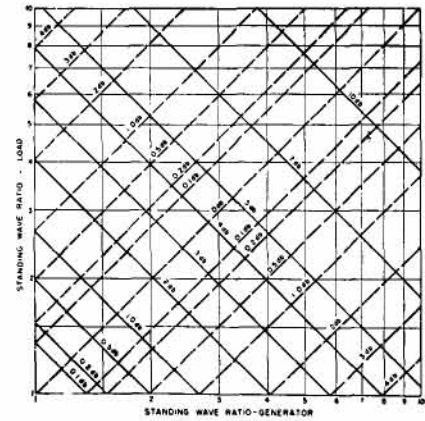

Figure 8: Power loss curves. Solid lines indicate P_{max} ; broken lines P_{min} . (Courtesy Sperry Gyroscope Co.)

between -30.52 dbm and -32.28 dbm. Without further information concerning the relative phase of the reflection coefficients, it is impossible to obtain this value more accurately. With some form of tuner, the load may be matched to the generator. Then the attenuator reads accurately as maximum power is transmitted to the load. For most measurements, it will be found that an average value of the power loss will adequately meet the accuracy requirements.

Loss in Cables: Another source of error in power output determination is loss in the cables connecting the generator to the load. This loss may become significant, particularly at higher frequencies. In order to eliminate this error, *-hp*- generators (except 620A) are calibrated in terms of power at the end of the cable. If cables of different lengths are used, consideration should be given to the differing attenuations in the cables. A nominal attenuation for several different types of cables is shown in Figure 9.

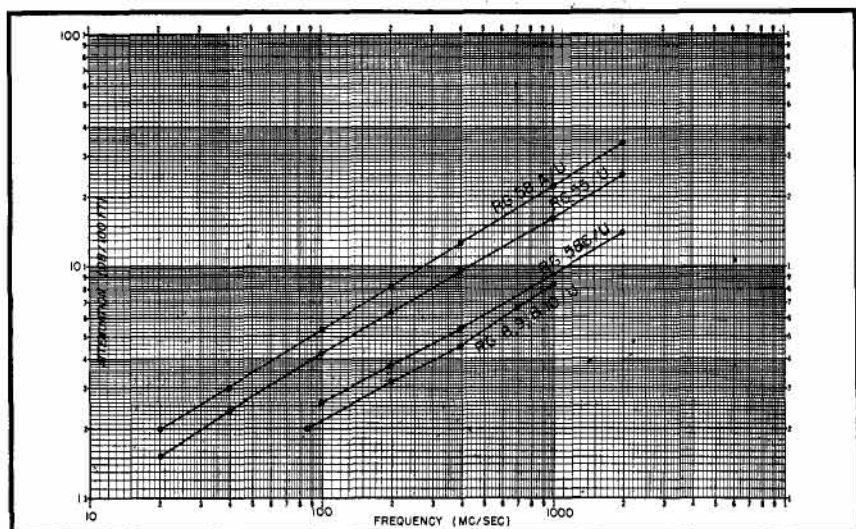

Figure 9: Attenuation vs. frequency curves for several cables.

hp 608C/D VHF SIGNAL GENERATORS



Advantages:

- New premium-quality performance
- Wide range, direct calibration
- Residual FM less than 1 KC
- Drift less than 0.005%.
- High power output
- Microsecond pulsing
- Broad modulation capabilities

Uses:

- Testing and aligning vhf communications receivers
- Measuring gain, sensitivity, selectivity, image rejection of receivers, if amplifiers, broad band amplifiers, and other vhf equipment.
- Driving bridges, slotted lines, antennas, filter networks, etc.

Finest Measuring Tools for 10 to 500 MC Band

HEWLETT-PACKARD 608C/D is designed as the ultimate in vhf signal generators. It offers the highest stability attained in production equipment of its type. There is almost a complete absence of residual FM (less than 1 KC). Frequency drift is held to less than 0.005% over a 10-minute period (after warmup). This performance is possible because of the master oscillator buffer output amplifier construction and close filament regulation of the tubes. Output is calibrated from 0.1 μ v to 0.5 v throughout the frequency range of 10 to 420 MC. A built-in crystal calibrator provides a frequency check accurate within 0.01% every 5 MC throughout range.

Premium Quality 608D

Modulation capabilities of -hp- 608D are extremely broad. For example, the instrument can be AM modulated up to 95% ; distortion is less than 5% at 30% modulation. It will provide high quality pulses as short as 1 μ sec at rf output frequencies above 100 MC. Modulation circuitry has flat response from 20 cps to 1 MC, hence a wide range of audio, carrier current and video modulations may be employed. Percentage modulation is read directly on the front panel meter.

Direct Calibration

As with other *-hp-* signal generators, output and frequency are also calibrated directly for fast reading without charts. The output circuit reads direct in both volts and dbm. Frequencies 10 to 420 MC are covered in 5 bands, presented directly in MC on a drum-type dial with effective scale length of 45". Tuning is highly accurate; there is no backlash. Resetability is better than 1 MC even at the high end of the band.

Finest Construction

An important feature of *-hp-* 608D is the new mechanical design and construction employed throughout. New aluminum castings and cabinets reduce weight at no sacrifice in strength or ruggedness. Circuitry is uniquely clean and accessible. Dial, condenser and turret drives are all precision built and ball-bearing equipped. Variable condensers are specially manufactured by *-hp-* and feature electrically welded Invar low temperature steel plates to minimize drift. Sealed transformers are used throughout, and construction is militarized.

-hp- 608C vhf Signal Generator

The *-hp-* 608C is a high power, stable, and highly accurate vhf signal generator for general laboratory and field use. Utilizing a master oscillator-power amplifier circuit, Model 608C provides 1 volt maximum output and a broad frequency coverage of 10 to 480 MC. It may be AM modulated to 95% and provides high quality pulses as short as 1 μ sec at rf output frequencies above 100 MC. As in *-hp-* 608D, rf leakage is negligible, and receiver sensitivity measurements to 1 μ v may be made.

-hp- 608C is especially suited for measurements of gain, selectivity, sensitivity or image rejection of receivers, if amplifiers, broad band amplifiers and other vhf equipment. It also provides ample output for driving bridges, slotted lines, transmission lines, antennas, filter networks, and other circuits operating in the vhf band.

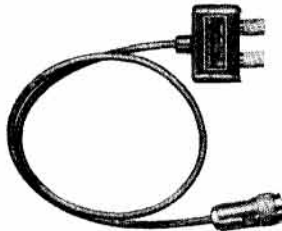

***-hp-* 608A-16D** Terminated Output Cable is designed for use with *-hp-* 608D and 608C vhf Signal Generators. It provides an accurate termination which may be directly connected to the point of a circuit at which the signal voltage is to be injected. \$10.00 f.o.b. factory.

Specifications

***-hp-* 608D**

Frequency Range: 10 to 420 MC, 5 bands.

Tuning Control: Main dial calibrated in MC. Vernier interpolation dial. 45" scale length. Calibrated every other MC, 130 to 270 MC; every 5 MC, above 270 MC.

Frequency Calibration Accuracy: $\pm 0.5\%$ full range.

Resetability: Better than $\pm 0.1\%$ after warmup.

Crystal Calibrator: Frequency check points every 5 MC through range. Headphone jack for audio frequency output.

Frequency Drift: Less than 0.005% over 10-minute interval after warmup.

Output Level: 0.1 μ v to 0.5 v into 50-ohm load. Attenuator dial calibrated in volts and dbm. (0 dbm equals 1 mw in 50 ohms.)

Voltage Accuracy: ± 1 db full range.

Generator Impedance: 50 ohms, maximum SWR 1.2.

Modulation Percentage: 0 to 95% at output of 0 dbm and below.

Envelope Distortion: Less than 5% at 30% sine wave modulation; less than 10% at 50% sine wave modulation.

Internal Modulation: 400 cps $\pm 10\%$ and 1,000 cps $\pm 10\%$.

External Modulation: 0 to 95%, 20 cps to 20 KC. For rf output above 100 MC, modulation frequencies up to 1 MC produce at least 30% modulation.

External Pulse Modulation: 5 v peak pulse required. Good pulse shape at 1 μ sec.

Modulation Meter Accuracy: $\pm 10\%$ of full scale reading to 95% modulation.

Residual FM: Less than 1,000 cycles at 50% AM for rf output frequencies above 100 MC; less than 0.001% below 100 MC.

Leakage: Negligible; permits sensitivity measurements to 1.0 μ v.

Filament Regulation: Provides highest possible oscillator and amplifier stability for line voltage change.

Power: 115/230 v $\pm 10\%$, 50/1,000 cps, 150 watts.

Dimensions: Cabinet Mount: 13 $\frac{3}{4}$ " wide, 16 $\frac{1}{8}$ " high, 20 $\frac{3}{8}$ " deep.

Weight: Net 61 lbs. Shipping 96 lbs.

Accessories Furnished: 1 M-72 Power Cord.

Accessories Available: 608A-16D Cable Assembly; AC-16K Video Cable Assembly; AC-16F rf Cable Assembly; 360A Low Pass Filter; 608A-95A Fuseholder \$20.00.

***-hp-* 608C**

Same as *-hp-* 608D, except:

Frequency Range: 10 to 480 MC, 5 bands.

Frequency Calibration Accuracy: $\pm 1\%$ full range.

Frequency Drift: Less than $\pm 0.01\%$ over a 10-minute interval after warmup.

Modulation Percentage: 0 to 95% at output of +7 dbm and below.

Crystal Calibrator: In Model 608D only.

Output Level: 0.1 μ v to 1.0 v into 50 ohm load.

Residual FM: Less than 0.0025% at 30% amplitude modulation for rf output frequencies 21 to 480 MC.

Data subject to change without notice.



612A UHF-TV SIGNAL GENERATOR



Advantages:

- Output 0.5 v over full range
- Uhf-TV modulation characteristics
- Direct calibration
- CW, AM and pulse output
- Low residual FM
- Constant internal impedance
- Microsecond pulsing
- No charts or interpolation

Use To:

- Measure gain, selectivity, sensitivity and image rejection of receivers and amplifiers
- Drive bridges, slotted lines, antennas and filter networks
- Test uhf-TV equipment under actual modulation conditions

All-Purpose Uhf-TV Signal Generator—450 to 1220 MC

HERE is an all-purpose, precision signal generator particularly designed for utmost convenience and applicability in measurements throughout the important uhf-TV frequency band. It is ideally suited for measurements in uhf television broadcasting, studio-transmitter links, public service communications, citizen's radio, marine communication systems, and aeronautical radio-navigation networks. In the laboratory it is also a convenient power source for driving bridges, slotted lines, antennas and filter networks.

MOPA Circuit

The unique master oscillator-power amplifier circuit in -hp- 612A provides a high output power of 0.5 v into 50 ohms over the full frequency range of 450 to 1220 MC. There is very low incidental FM (less than 0.002% at 30% AM) and excellent modulation capabilities by all

frequencies from 20 cps to 5 MC. The instrument may be modulated internally or externally, amplitude modulated, or pulse modulated (good rf pulses 0.2 μ sec or longer). Pulse modulation may be applied to the amplifier, or direct to the oscillator when high on-off signal ratios are required. (Signal may be completely cut off during pulses.) A dc restorer circuit allows modulation up or down from preset level to simulate TV modulation characteristics accurately. The large, easily read percentage modulation meter responds to peak value, indicating exact degree of pulse modulation.

New Advanced Design

The oscillator-amplifier circuit in -hp- 612A employs high frequency pencil triodes in a cavity-tuned circuit for precise tracking over the entire band. The tuned cathode, tuned-plate oscillator drives a double-tuned power amplifier of 15 MC band width. (This circuitry produces the high modulation percentages to 5 MC and minimum incidental FM which characterize the instrument.)

Non-contacting cavity plungers are die cast to precise tolerances, then injection molded with a plastic filler for optimum Q. The frequency drive is a direct screw-operated mechanism, free from backlash. A waveguide beyond cutoff piston attenuator and crystal monitor circuit are used to insure accurate, reliable output down to 0.1 μ v. The attenuator is calibrated over a range of 131 db. It has been carefully designed to provide a constant impedance versus frequency characteristic. The SWR of the output system is less than 1.2 over the complete frequency range when used into a 50 ohm impedance.

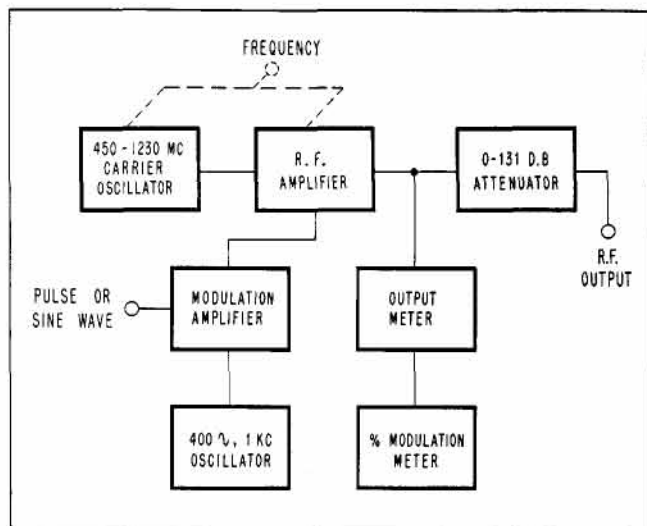

Figure 1. Block diagram, -hp- 612A uhf-TV Signal Generator.

The -hp- 612A covers the 450 to 1220 MC band in one continuous range. The tuning dial has an expanded scale that covers 15 inches and is calibrated every 5 megacycles. The dial can be read to approximately 1 megacycle and is accurate within 1%.

Specifications

Frequency Range: 450 to 1,220 MC in one band. Scale length approximately 15 inches.

Calibration Accuracy: Within $\pm 1\%$. Resettability better than 5 MC at high frequencies.

Output Voltage: 0.1 μ v to 0.5 v into 50 ohm load. Calibrated in volts and dbm (0 dbm = 1 mw, 50 ohms).

Output Accuracy: ± 1 db, entire frequency and attenuation range.

Internal Impedance: 50 ohms. Maximum SWR 1.2.

Leakage: Negligible. Permits receiver sensitivity measurements down to 1 μ v.

Amplitude Modulation: 0 to 90% at af, indicated by panel meter. Accuracy, $\pm 10\%$.

FM Due to Amplitude Modulation: Less than 0.002% for 30% AM.

Internal Modulation: 400 cps and 1,000 cps $\pm 10\%$.

External Modulation: 20 cps to 5 MC. 2 v rms across 2,000 ohms produces 90% AM for modulating frequencies up to 1 MC; at least 40% at 5 MC.

Envelope Distortion: Less than 2% at 30% af modulation.

Pulse Modulation: (a) Pulse to amplifier: 0.2 μ sec or longer positive or negative rf output pulse. 4 to 40 v peak external modulating pulse required. On-off ratio at least 20 db.

(b) Pulse to oscillator: 1 μ sec or longer positive rf output pulse. 4 to 40 volts peak external modulating pulse required.

Dc Restorer: Permits modulation up or down from set level in addition to normal modulation.

Connectors: (a) rf Output, Type N.

(b) External Modulation, Banana jack BP, spaced $\frac{3}{4}$ ".

(c) Pulse Input, Type BNC.

Power: 115/230 v $\pm 10\%$, 50/1,000 cps, 200 watts.

Dimensions: Cabinet Mount: 12" wide, 15" high, 20 $\frac{7}{8}$ " deep.

Weight: Net 57 lbs. Shipping 100 lbs.

Accessories Furnished: M-72 Power Cord.

Accessories Available: AC-16F rf Cable Assembly; AC-16K Video Cable Assembly; 360B Low Pass Filter (may be used where harmonic output must be reduced to a minimum, as in slotted line measurements).

Data subject to change without notice.



614A/616A UHF SIGNAL GENERATORS

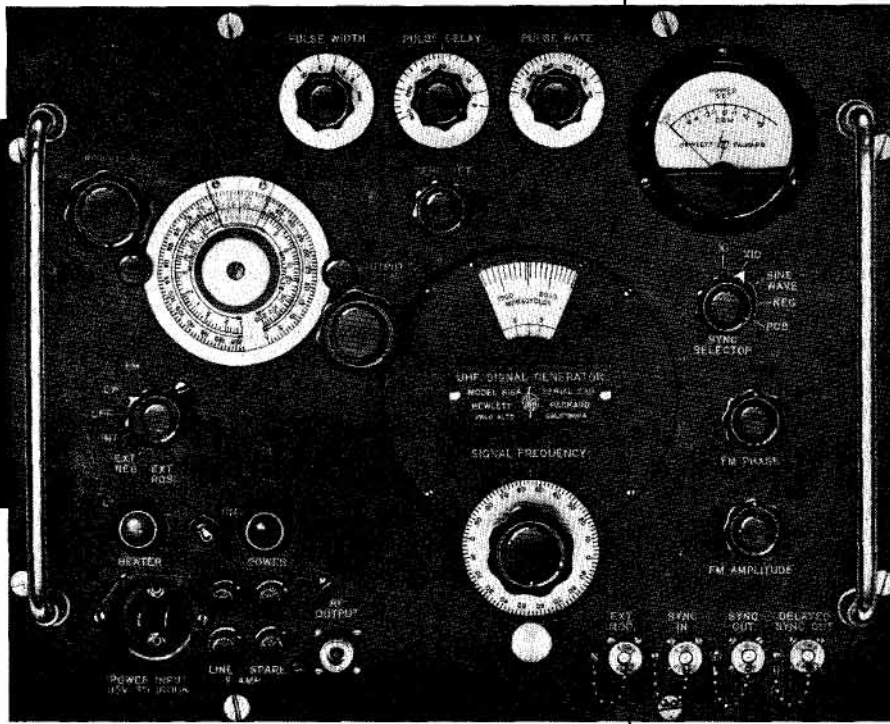

Advantages:

- Direct frequency control
- Direct voltage readings
- CW, FM or pulsed output
- Variable pulse rate
- Synchronized pulsing
- Wide frequency range
- High stability
- Rugged, compact, dependable

Use To Measure:

- Receiver sensitivity
- Signal-to-noise ratio
- Conversion gain
- Standing wave ratios
- Antenna gain
- Transmission line characteristics

Direct Reading, Direct Control 800 to 2,100 MC, 1,800 to 4,000 MC

EASE of operation, direct reading without calibration charts, one-dial frequency control, high stability, precision accuracy and broad frequency coverage—all are outstanding advantages of these two widely-used *-hp-* signal generators.

-hp- 614A covers frequencies from 800 to 2,100 MC, has constant internal impedance with less than 1.6 SWR, and output accuracy of ± 1 db over the range of -10 dbm to -127 dbm.

-hp- 616A gives complete coverage of frequencies from 1,800 to 4,000 MC, has constant internal impedance with less than 1.8 SWR, and output accuracy of ± 1.5 db from -7 dbm to -127 dbm.

On both instruments, operation is extremely simple. Carrier frequency in MC is set and read directly on the large tuning dial. No voltage adjustments are necessary during operation because of the unique coupling device which causes oscillator repeller voltage to track frequency changes automatically. Oscillator output is set and read directly on a simplified dial. Output may be continuous or pulsed, or frequency modulated at power supply frequency. Pulse modulation may be provided externally or inter-

nally. Internal pulsing may be synchronized with either positive or negative external pulses, or sine waves.

The oscillator portion of both *-hp- 614A* and *616A* is of the reflex klystron type, with an external resonant cavity. Frequency of oscillation is determined by a movable plunger which varies the parameter of the cavity. Oscillator output is monitored by a temperature-compensated thermistor bridge circuit which is virtually unaffected by ambient temperature conditions. Voltage beyond the monitored output level is passed through a piston attenuator designed so that attenuation is linear over a range of 120 db or more. Voltage output is read directly on the scale.

Because of their wide range and great stability, *-hp- 614A* and *616A* Signal Generators are ideal for almost all precision uhf measurements. They are compact in size and ruggedly built of highest quality components for long, trouble-free service.

Specifications

-hp- 614A

Frequency Range: 800–2,100 MC directly calibrated.

Frequency Calibration: Accuracy $\pm 1\%$.

Frequency Stability: 0.005%/°C change in ambient temperature. Line voltage changes of $\pm 10\%$ cause less than 0.01% frequency change.

Output Range: 1 milliwatt or 0.223 v to 0.1 μv . (0 dbm to -127 dbm.) Directly calibrated in μv and db; continuously monitored. Attenuator accuracy ± 1 db from -10 dbm to -127 dbm.

Internal Impedance: 50 ohms. SWR less than 1.6.

Modulation: Internal or external pulse or FM.

Internal Pulse Modulation: Pulse repetition rate variable from 40 to 4,000 per second; pulse length variable from 1 to 10 μsec . Pulse rise and decay approx. 0.1 μsec .

External Pulse Modulation: By external pulses, pos. or neg. peak amplitude 40 to 70 v, 1.0 μsec to square wave.

Trigger Pulses Out: (1) Simultaneous with rf pulse. (2) In advance of rf pulse, variable 3 to 300 μsec . (Both approx. 1 μsec rise time, height 10 to 50 v.)

External Sync Pulse Required: Amplitude from 10 to 50 v of either pos. or neg. polarity; and 1 to 20 μsec width. May also be synchronized with sine waves.

FM Modulation: Oscillator frequency sweeps at power line frequency. Phasing and sweep range controls provided. Max. deviation approx. ± 5 MC.

Power: 115/230 v $\pm 10\%$, 50/1,600 cps, 130 watts.

Dimensions: Cabinet Mount: 16 $\frac{3}{4}$ " wide, 13 $\frac{1}{2}$ " high, 13 $\frac{5}{8}$ " deep.

Weight: Net 60 lbs. Shipping 102 lbs.

Accessories Furnished: 2 AC-16K Video Cable Assemblies; 1 61B-16H Power Cable Assembly; 1 AC-16F rf Cable Assembly.

Accessories Available: 360C Low Pass Filter.

-hp- 616A

Frequency Range: 1,800 to 4,000 MC. Selection is made by means of a single directly-calibrated control covering the entire range. No charts are necessary.

Frequency Calibration Accuracy: $\pm 1\%$.

Frequency Stability: 0.005%/°C change in ambient temperature; line voltage changes of ± 10 v cause less than 0.01% frequency change.

Output Range: 1 milliwatt or 0.223 v to 0.1 (0 dbm to -127 dbm). Directly calibrated in microvolts and db; continuously monitored.

Attenuator Accuracy: Within ± 1.5 db from -7 dbm to -127 dbm without correction charts. A correction chart is provided when greater accuracy is desired.

Internal Impedance: 50 ohms, nominal. SWR less than 1.8.

Modulation: Internal or external pulse or FM.

Internal Pulse Modulation: Repetition rate variable from 40 to 4,000 per second; pulse length variable from 1 to 10 μsec ; and delay variable from 3 to 300 μsec (between synchronizing signal and rf pulse).

External Pulse Modulation: Pulse requirements: Amplitude from 40 to 70 v positive or negative, width 1.0 μsec to square wave.

Trigger Pulses Out: (1) Simultaneous with rf pulse. (2) In advance of rf pulse, variable 3 to 300 μsec . (Both approximately 1.0 μsec rise time, height 10–50 volts.)

External Sync Pulse Required: Amplitude from 10 to 50 volts of either positive or negative polarity and 1 to 20 μsec width. May also be synchronized with sine waves.

FM Modulation: Oscillator frequency sweeps at power line frequency. Phasing and sweep range controls provided. Maximum deviation approximately ± 5 MC.

Power: 115/230 v $\pm 10\%$, 50/1,600 cps, 160 watts.

Dimensions: Cabinet Mount: 16 $\frac{3}{4}$ " wide, 13 $\frac{1}{2}$ " high, 13 $\frac{5}{8}$ " deep.

Weight: Net 62 lbs. Shipping 105 lbs.

Accessories Furnished: 2 AC-16K Video Cable Assemblies; 1 61B-16H Power Cable Assembly; 1 AC-16F rf Cable Assembly.

Accessories Available: 360D Low Pass Filter.

Data subject to change without notice.

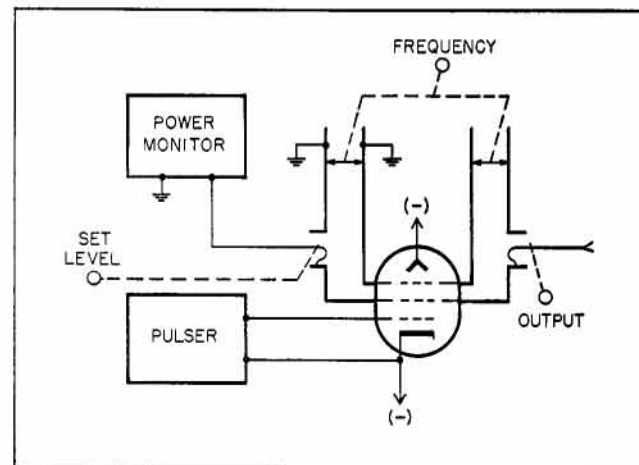
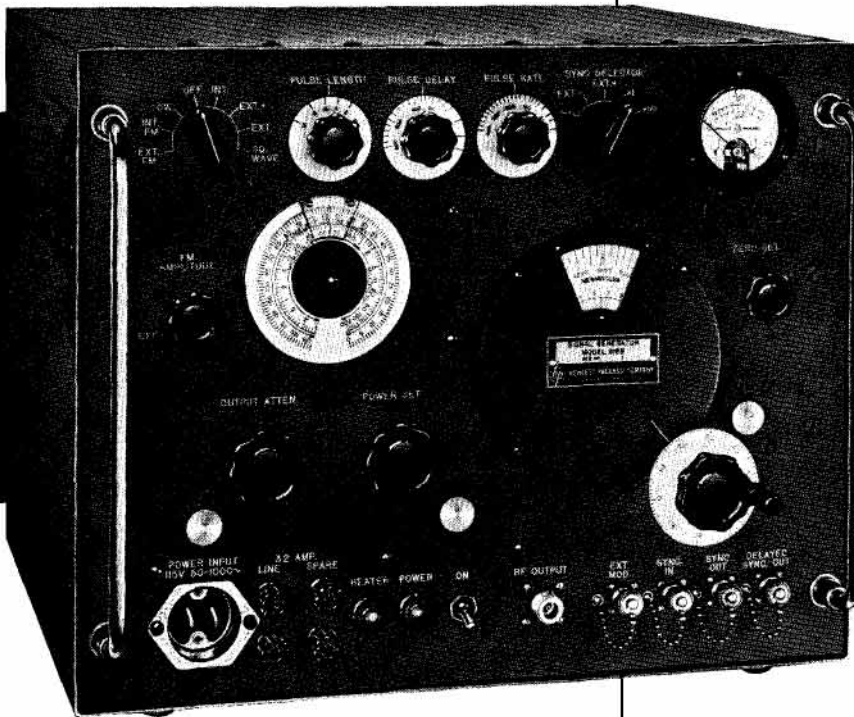

Figure 1. Block Diagram, *-hp- 614A* Signal Generator.

hp 618B/620A SHF SIGNAL GENERATORS



Advantages:

- Direct reading frequency control
- Direct output voltage control
- FM, CW, pulsed or square wave output
- Internal square wave modulation
- Broad pulsing capabilities
- Wide frequency range
- High stability, high accuracy
- Sturdy, compact, precision built

Use To Measure:

- Receiver sensitivity
- Selectivity or rejection
- Signal-to-noise ratio
- Conversion gain, SWR
- Antenna gain
- Transmission line characteristics

Widely Varied Pulsing Capabilities for Measurements 3,800 to 11,000 MC

NEW *hp*- 618B and 620A shf Signal Generators bring the simple yet versatile operation and the varied pulsing capabilities of *hp*- uhf Signal Generators to the 3,800 to 11,000 MC frequency range.

These new generators offer internal or external pulse modulation, internal square wave modulation, and FM. The repetition rate is continuously variable from 40 to 4,000 pps, and pulse width is variable from 0.5 to 10 microseconds. Sync-out signals are simultaneous with the rf pulse, or in advance of the rf pulse by any time span from 3 to 300 microseconds. The instruments may be synchronized with an external sine wave or with positive or negative pulse signals.

Saw-Tooth Sweep

For internal frequency modulation, both *hp*- 618B and 620A offer a saw-tooth sweep rate variable from 40 to 4,000 pps. Frequency deviation is variable up to ± 3 MC. For external FM, the instruments provide capacitive coupling to the repeller of the klystron oscillator. Maximum deviation is approximately ± 5 MC.

Both generators maintain the same high standards of accuracy found in -hp- vhf and uhf Signal Generators. Both also feature the same simple operation. Carrier frequency is set and read directly on the large central tuning dial. (Calibration of this dial is linear.) No voltage adjustments are necessary during operation because of an exclusive -hp- developed coupling device which causes oscillator repeller voltage to track frequency changes automatically. Rf output is also set and read directly; no calibration charts are needed either for voltage or frequency control or determination.

Reflex Klystron Oscillator

The 618B and 620A Generators both feature oscillators of the reflex klystron type, with external resonant cavity. Oscillator frequency is determined by a movable plunger which varies the length of the cavity. Oscillator output is monitored by a temperature-compensated thermistor bridge circuit. This circuit operates virtually unaffected by ambient temperature conditions. Voltage beyond the monitored output level is passed through a piston attenuator. Attenuation is linear over a range of 120 db or more.

Models 618B and 620A are designed to be the most broadly useful, accurate and dependable signal generators available in their frequency ranges. Their high stability, broad frequency coverage, precision accuracy and varied pulsing capabilities make them ideal for virtually all measurements requiring precisely known and controllable shf signals. They are sturdily built of the best components, many parts being specially manufactured for or by Hewlett-Packard. Circuitry is uniquely clean and accessible. The generators are designed for years of dependable service with little or no maintenance.

Specifications

-hp- 618B

Frequency Range: 3,800 to 7,600 MC covered in a single band. Repeller voltage automatically tracked and proper mode automatically selected.

Calibration: Direct reading. Frequency calibration accuracy better than 1%.

Frequency Stability: Frequency variation less than 0.006% per degree centigrade change in ambient temperature. Line voltage change of ± 10 volts causes less than 0.02% frequency change.

Output Range: 1 milliwatt or 0.223 volt to 0.1 microvolt (0 dbm to -127 dbm) into 50 ohms. Directly calibrated in microvolts and db (coaxial Type N connector).

Output Accuracy: Within ± 2 db -7 dbm to -127 dbm into 50 ohms.

Internal Impedance: 50 ohms nominal. SWR less than 2.

Modulation: Internal or external pulse, FM, square wave.

Internal Pulse Modulation: Repetition rate variable from 40 to 4,000 pps, pulse width variable 0.5 to 10 μ sec.

Sync Out Signals: 1. Simultaneous with rf pulse—positive. 2. In advance of rf pulse—positive, variable 3 to 300 μ sec. (Better than 1 μ sec rise time and 25 to 100 volts amplitude into 1,000 ohm load.)

External Synchronization: 1. Sine wave: 40 to 4,000 cps, amplitude 5 to 50 volts rms. 2. Pulse signals: 0 to 4,000 pps and 5 to 50 volts amplitude, both positive and negative, pulse width 0.5 to 5 μ sec, rise time 0.1 to 1 μ sec.

Internal Square Wave Modulation: Variable 40 to 4,000 cps, controlled by "pulse rate" control.

Internal Frequency Modulation: Saw-tooth sweep rate adjustable between 40 to 4,000 cps. Frequency deviation up to ± 3 MC.

External Pulse Modulation: Pulse requirements: amplitude from 15 to 70 volts positive or negative, width 0.5 to 2,500 μ sec.

External Frequency Modulation: Provides capacitive coupling to repeller of klystron. Max. deviation approx. ± 5 MC.

Power: 115/230 v $\pm 10\%$, 50/1,000 cps, 250 watts.

Dimensions: Cabinet Mount: 17 $\frac{1}{8}$ " wide, 13 $\frac{3}{8}$ " high, 17 $\frac{5}{8}$ " deep.

Weight: Net 95 lbs. Shipping 175 lbs.

Accessories Furnished: 2 AC-16K Video Cable Assemblies; 1 61B-16H Power Cable Assembly; 1 AC-16Q rf Cable Assembly.

-hp- 620A

(Same as -hp- 618B except:)

Frequency Range: 7,000 to 11,000 MC covered in a single band. Repeller voltage automatically tracked and proper mode automatically selected.

Output Range: 0.1 milliwatt or 0.071 volt to 0.1 microvolt (-10 dbm to -127 dbm) into 50 ohms. Directly calibrated in microvolts and db (coaxial Type N connector). Uncalibrated output approximately 1 milliwatt over most of band.

Output Accuracy: Within ± 2 db from -10 dbm to -127 dbm at panel connector, terminated in 50 ohm load.

Data subject to change without notice.

hp 624C/623B SHF TEST SETS

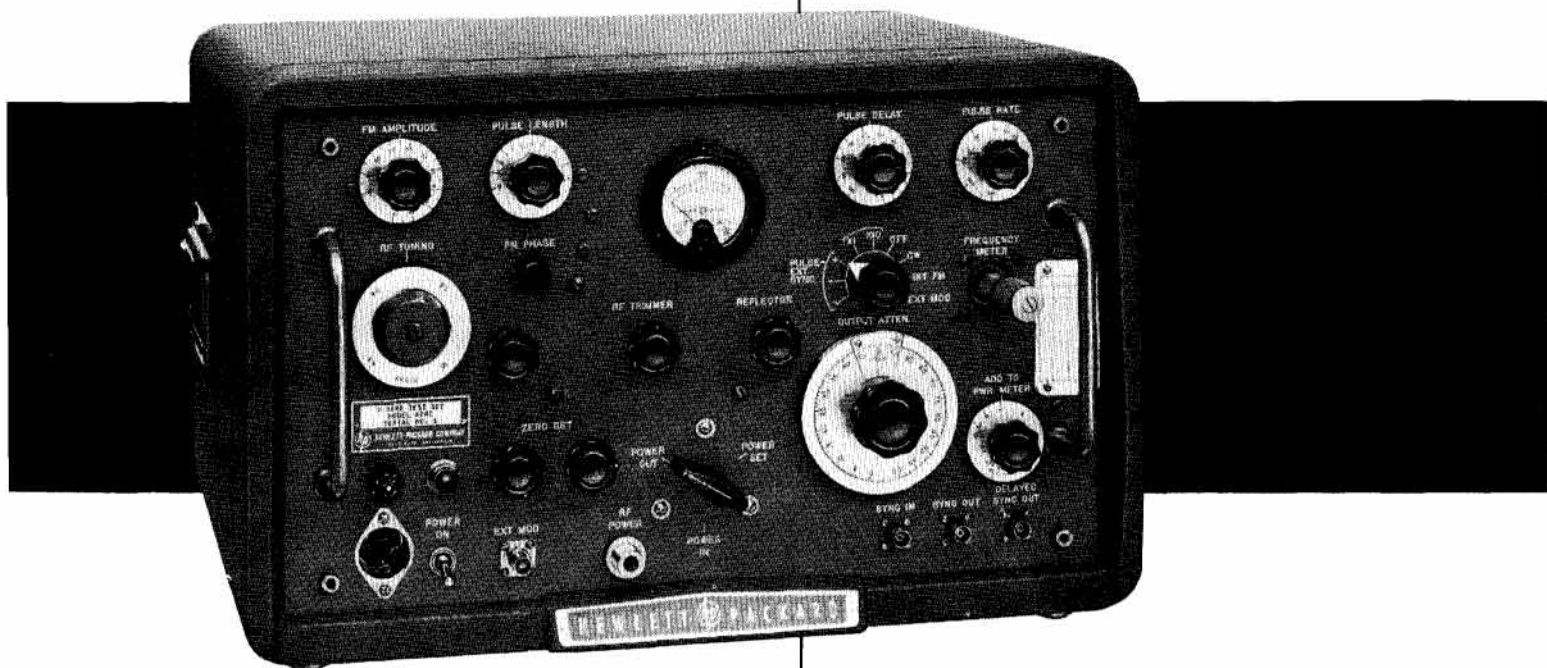

Advantages:

- .223 volt maximum rf output
- Direct tuning, direct reading
- Pulse and FM modulated output
- Stable, accurate 100 db attenuator
- Variety of high-quality rf pulses
- Compact, sturdy, easily portable

Uses:

- Measure receiver sensitivity
- Measure selectivity
- Transmitter tuning, power level
- Testing complete radar, gunfire control or beacon systems
- Determine external rf power or external frequency

High-Level, Direct-Reading Test Sets for Laboratory, Field Work

MODEL 624C Test Set is a high-level, accurate, multi-purpose instrument designed to speed and simplify a wide variety of tests between 8,500 and 10,000 MC. It is an ideal one-piece unit for measuring receiver sensitivity or selectivity, transmitter tuning or power level, and is particularly adapted to testing complete radar or gunfire control systems or beacon equipment. The instrument includes pulsing circuitry providing a variety of high-quality rf pulses.

-hp- 624C consists of a signal generator and a power and frequency meter section. The generator includes a modern klystron generator with excellent frequency stability and an output attenuator of the waveguide-beyond-cutoff type, insuring high-accuracy and stability. The attenuator is not subject to temperature, humidity or age changes. The power and frequency meter section can be used to adjust the signal generator's frequency and level as well as measure external rf energy. The instrument employs 50 ohm Type N coaxial connectors, and for maximum versatility includes an adapter for waveguide connection.

-hp- 623B Test Set is designed for operation at any frequency between 5,925 MC and 7,725 MC. This overall frequency range is covered in three bands, each of which is a full 600 MC wide. Bands are selected by installation of the proper klystron tube (see specifications). The instrument is particularly useful in field-testing shf radio relay stations and communications equipment as well as general tests involving FM modulated equipment. It includes a 1,000 cps modulator and may also be square-waved or pulsed by external sources with frequencies ranging from 60 cps to 100 KC.

Both **-hp- 624C** and 623B can be supplied either for cabinet or rack mount. The 624C has the Model AC-44 cabinet shown at left while the 623B has a splash proof metal case, the cover of which can be used for storing accessories for transit.

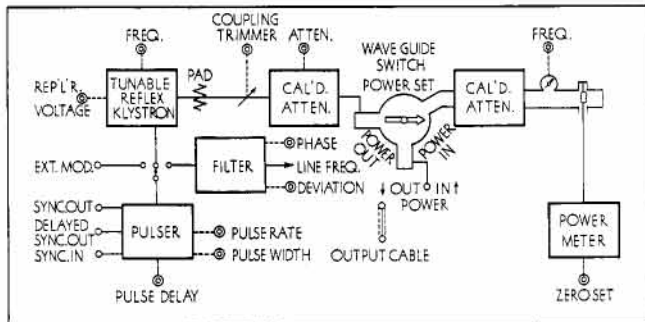

Figure 1. Simplified circuit diagram **-hp- 624C** Test Set.

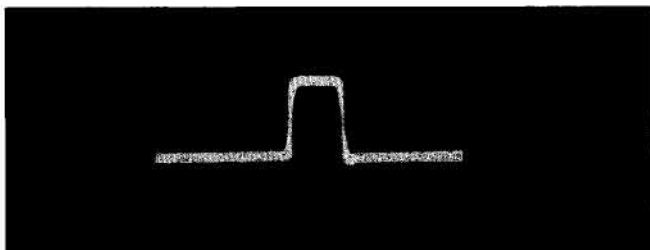

Figure 2. Typical rf pulse, 0.25 μ sec, 624C.

Specifications

-hp- 624C X-Band Test Set

Range: 8,500 to 10,000 MC.

Output: 0 dbm (1 mw) to -100 dbm (0.223 v to 2.23 μ v) into 50-ohm load. Type N jack. SWR less than 2.

Output Accuracy: Within ± 2 db, -10 to -100 dbm into matched load.

Internal Modulation: Pulsed or FM.

External Modulation: Pulse, FM or square wave.

Internal Pulse Modulation: Length variable from 0.25 to 10 μ sec. Rise time less than 0.06 μ sec. Decay time less than 0.12 μ sec. Rate variable 35 to 3,500 pps.

External Sync: Internal pulser operates free-running or in sync with external 5 to 50 v peak pulse, pos. or neg., or 5 to 50 v rms sine waves, or 5 to 50 v peak square wave. May be externally square-wave modulated. BNC jack.

FM: Internal FM at power line frequency. ± 7.5 MC deviation max. Also FM modulation by external 35 to 3,500 cps voltage.

Trigger Pulses: (a) Simultaneous with rf pulse, positive. (b) Variable, 2 to 250 μ sec ahead of rf pulse, positive. In either case amplitude greater than 10 v across 10,000 ohms. Pulse duration approx. 2 μ sec; rise time less than 0.8 μ sec.

Power Meter: Range -6 dbm to $+27$ dbm, accurate within ± 1 db. Input attenuator calibrated 0-25 db. Total input range, -6 to $+28$ dbm.

Frequency Meter: Full range, accurate within 0.03% at 25°C ambient.

Power: 115/230 v $\pm 10\%$, 50/60 cps, 200 watts.

Dimensions: Cabinet Mount: 20 $\frac{3}{4}$ " wide, 12 $\frac{5}{8}$ " high, 16 $\frac{1}{4}$ " deep. Rack Mount: 19" wide, 10 $\frac{1}{2}$ " high, 14" deep.

Weight: Net 56 lbs. Shipping 96 lbs. (cabinet mount).

Accessories Furnished: 1 M-72 Power Cord; 1 AC-16Q rf Cable Assembly; 1 X281A Adapter.

Accessories Available: AC-16K Video Cable Assembly.

-hp- 623B shf Test Set

Overall Frequency Range: 5,925 to 7,725 MC.

Operating Ranges

5,925 - 6,575

6,575 - 7,175

7,175 - 7,725

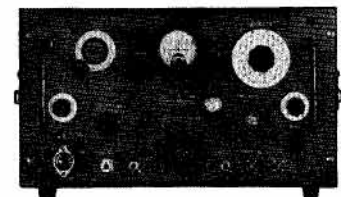

Note: Test set supplied with one klystron for any one of the above frequency ranges.

Output: 0 dbm (1 mw) to -70 dbm (0.223 v to 70 μ v) into 50 ohm load. Direct-reading control.

Output Accuracy: Within 2 db, 0 to -70 db, into matched load. SWR less than 2.

Internal Modulation: FM from 1,000 cps internal source. Phase and deviation adjustable. Max. deviation at least ± 10 mc.

External Modulation: FM, 30 cps to 10 KC. May be pulsed or square-waved externally, 30 to 100,000 cps.

Detector Output: Crystal detector to provide rectified output when FM or pulsed power applied.

Power Meter: Range -6 dbm to $+3$ dbm, accurate within ± 1 db.

Power: 115/230 v $\pm 10\%$, 50/60 cps, 150 watts.

Dimensions: Cabinet Mount: 21" wide, 12" high, 14" deep. Rack Mount: 19" wide, 10 $\frac{1}{2}$ " high, 14" deep.

Weight: Net 56 lbs. Shipping 96 lbs. (cabinet mount).

Accessories Furnished: 1 M-72 Power Cord; 2 AC-16Q rf Cable Assemblies; 1 J281A Adapter; 1 212-44 Spare Crystal; 1 Spare Thermistor.

Accessories Available: AC-16K Cable Assembly.

Data subject to change without notice.

670HM SHF SWEPT FREQUENCY OSCILLATOR

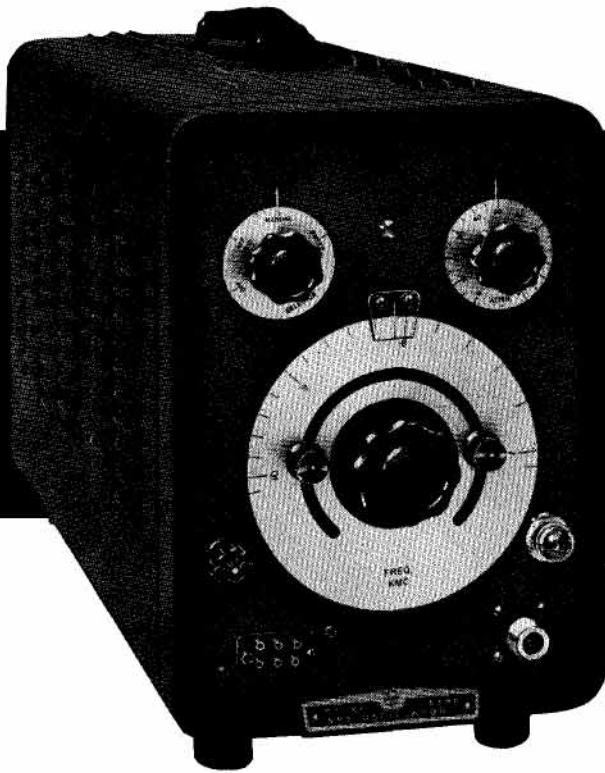

Advantages:

- Covers 7 to 10 KMC
- 10 mw output full range
- Automatic frequency sweep
- Fully adjustable sweep
- Full modulation capabilities
- Direct-reading dial

Use It For:

- Reflectometer measurements
- Rapid reflection coefficient checks
- Determining load impedance
- Waveguide test voltages
- Low-level shf voltages
- Slotted line measurements
- Microwave system frequency response

New Automatic-Sweep Microwave Oscillator—7 to 10 KMC

THIS unique new instrument is a compact, efficient and versatile source of test voltage at all frequencies from 7,000 to 10,000 megacycles. It provides at least 10 milliwatts of power throughout range. Attenuation is of the waveguide beyond-cutoff type, which provides 100 db of attenuation and makes possible the generation of low-level voltages at microwave frequencies.

Automatic Frequency Sweep

A unique feature of *-hp-* 670HM is the automatic, adjustable mechanical frequency sweep.

The instrument's frequency control dial is equipped with two adjustable stops. These stops locate upper and lower limits of a mechanical sweep which may be set to generate frequencies over 10% or any larger portion of the instrument's range. The sweep system operates at a constant velocity selected to provide an easily seen trace

on a medium-persistence cathode ray tube. A linear sweep voltage proportional to the mechanical sweep is available for horizontal oscilloscope deflection. By use of this sweep voltage the oscilloscope presentation will be a frequency panorama with the horizontal sweep distance proportional to frequency.

-hp- 670HM is normally supplied complete with mechanical sweep. However, if desired, the instrument can be supplied for manual tuning as the 670H at lower cost. Automatic sweep feature may be added later.

Varied Modulation Capabilities

Arrangements for grid and reflector modulation are provided. In use with a companion instrument, -hp- 717A Klystron Power Supply, the following kinds of modulation are available: a 60-cycle sine wave for FM with the reflector, or a square wave with a repetition frequency continuously variable from 400 to 1000 cps which may be applied to the reflector or grid. For greater versatility external modulating voltages can be applied.

During automatic sweeping, grid modulation is used since reflector voltage tracks frequency changes. In manual use, grid modulation may also be employed. In this case the reflector may be arranged to track automatically.

Reflector modulation is available with either AM or FM output. In this type of operation, reflector voltage is adjusted for optimum output at each operating frequency. (This adjustment is provided on -hp- 717A Power Supply. See Power Supply section of this catalog.)

Versatile Application

Model 670HM is a versatile source of both fixed frequencies and swept frequencies for all types of microwave measurements where a high level test signal is required. It is particularly useful for slotted line measurements and checks of transmission system characteristics; and is ideal as a source of either fixed or swept frequencies for reflection coefficient measurements. (Model 670HM is uniquely adapted for operation with the -hp- 416A Ratio Meter to form a high speed, accurate combination of equipment for measurement of reflection coefficient. Suggested arrangement of equipment for this use is shown in Figure 4, page 96.)

Operation

The principle operating features of the -hp- 670HM (670H with sweep motor attached) are shown in Figure 1. The sweep motor shaft produces three simultaneous results: (1) Through a rack and pinion gear arrangement shorting plungers are moved in and out within the resonant cavity; (2) The reflector voltage is at the same time being tracked so as to insure accurate frequency control; (3) The sweep voltage is tracked so as to be available as an oscilloscope input.

Specifications

Frequency Range: 7.0 to 10.0 KMC.

Output Power: At least 10 mw full range.

Attenuator Range: 100 db.

Modulation: (a) Grid modulation for optimum swept-frequency performance. (b) Reflector modulation for optimum single-frequency performance. Modulating signals must be provided from external source (normally the -hp- 717A Power Supply). Pulses as short as 3 microseconds can be produced.

Mechanical Sweep: Fully adjustable to cover any 10% or larger portion of the 7.0 to 10.0 KMC spectrum. Sweep rate 12 to 60 complete cycles per minute depending on swept frequency range.

Sweep Voltage Provided: Linear voltage proportional to mechanical sweep. (Approximate 50 volts change equivalent to maximum swept frequency range.)

Connectors: (a) Rf output: coaxial Type N on panel; (b) Sweep voltage: Type BNC, at rear; (c) Power supply: special mating connector furnished.

Power: 115 v \pm 10 v, 50/60 cps, 25 watts internal. Requires external power supply for operating type 5721 Klystron. (-hp- 717A Power Supply recommended.) Power required: 1000 volts, 20 ma; 0 - 600 volts, 5 ma; 6.3 volts ac, 0.6 ma.

Klystron: Type 5721, supplied with instruments.

Dimensions: Cabinet Mount: 7 $\frac{1}{4}$ " wide, 11" high, 21 $\frac{1}{4}$ " deep.

Weight: Net 31 lbs. Shipping 50 lbs.

Accessories Furnished: 1 Power Supply Special Mating Connector, 1 M-72 Power Cord.

Accessories Available: AC-16D Video Cable Assembly; AC-16Q rf Cable Assembly; 717A Klystron Power Supply; -hp- AC-97A Sweep Motor assembly, \$100.00 (Supplied on 670HM).

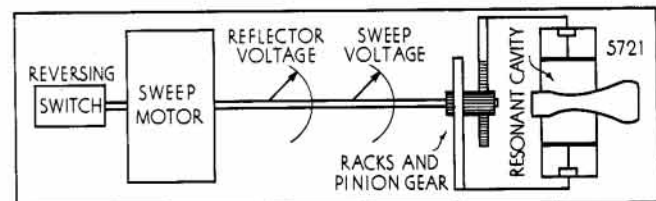

Figure 1. Operating diagram of 670HM Swept Frequency Oscillator.

Data subject to change without notice.

hp 710B POWER SUPPLY



Specifications

Voltage Range: Output continuously variable from 100 to 360 volts. Either positive or negative output terminal may be grounded. 6.3 volts ac, center-tapped, also provided.

Regulation: Output constant to approximately 1% for loads of from 0 to 75 ma, and line voltage variations of ± 10 volts for any setting. A maximum of 100 milliamperes can be drawn.

Noise and Hum: Total noise and hum is less than 0.005 volts for any condition of operation.

Power: 115/230 v $\pm 10\%$, 50/1,000 cps, 90 watts.

Dimensions: Cabinet Mount: 7 $\frac{3}{4}$ " wide, 8 $\frac{3}{4}$ " high, 11 $\frac{3}{4}$ " deep. Rack Mount: 19" wide, 8 $\frac{3}{4}$ " high, 11" deep.

Weight: Net 15 lbs. Shipping 28 lbs.

Data subject to change without notice.

High-Stability Regulated dc or ac

THE -hp- Model 710B Power Supply is an excellent source of dc power for every laboratory and production department use. It has been designed to give the ultimate in flexibility, compactness, portability, and economy. Output is continuously variable between 100 and 360 volts, and is practically independent of either line voltage or applied load for any setting. The noise and hum level is very low for any condition of operation. The output is stable over long periods of time. Its small size requires a minimum of bench space when in use, and little storage space when idle. Since many set-ups which call for a source of well-regulated dc also require an ac source for supplying filaments, a center-tapped, 6.3 volt source which will supply 5 amps ac has been included. The low cost makes it practical and economical to employ several of these instruments simultaneously.

Uses

Because of its stability and low noise level, the -hp- Model 710B Power Supply can be used in place of batteries in many applications. In such service its long life, dependability, and portability result in real savings, both in time and money. It may be used to power low-level amplifiers, constant frequency oscillators, and any equipment requiring a voltage source of high stability. One of its outstanding uses is in supplying power for temporary set-ups, "breadboard" layouts, and the like.



711A LABORATORY POWER SUPPLY

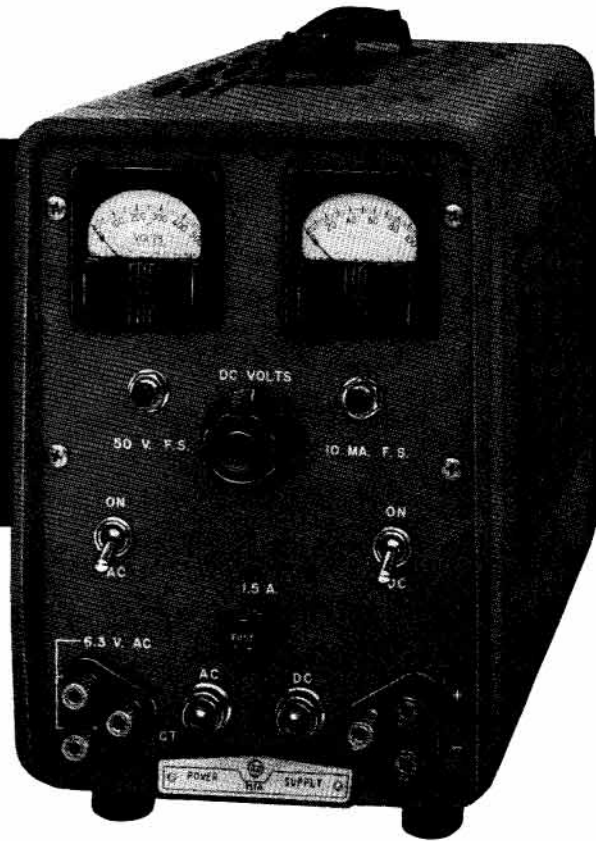

Specifications

Output Voltages:

Dc Regulated High Voltage: 0 to 500 volts (without switching), 100 ma maximum load.

Ac Unregulated: 6.3 volts CT, 5 amps maximum load.

Regulation: (for line voltage 115 volts $\pm 10\%$.) Less than $\pm 0.25\%$ change or 0.5 volt change, whichever is greater, no load to full load.

Ripple: Less than 1.0 mv.

Metering:

Current Meter: 0 to 100 ma; 0 to 10 with push-button.

Voltage Meter: 0 to +500 volts; 0 to +50 volts with push-button.

Terminals: Either positive or negative dc regulated high voltage terminal may be grounded.

Overload Protection: Ac line fused. Output relay prevents dc output from greatly exceeding current rating of output milliammeter thus protecting instrument from overload conditions including short circuit of output.

Power: 115 volts $\pm 10\%$, 50-1,000 cps. Approximately 150 watts depending on load and line voltage.

Size: 7 $\frac{3}{4}$ " wide, 11" high, 12" deep.

Weight: 18 pounds. Shipping weight, 30 pounds.

Data subject to change without notice.

High Regulation, 0 to 500 Volts, Separate Meters

NEW -hp- 711A is an easy-to-use, general purpose low power laboratory supply particularly suited to powering experimental setups and other basic bench applications. It offers very high regulation, and a wide, variable voltage range extending from 0 to 500 volts. There are separate current and voltage meters with two ranges each to permit accurate measurement of small power outputs. Full overload protection is provided to protect the instrument even under short-circuit output conditions.

Uses

Similar to -hp- 710B except for its much wider voltage range, Model 711A can be used in place of batteries, or to power a wide variety of equipment. It is particularly useful in driving low level amplifiers, constant frequency oscillators and other instruments or setups requiring a highly stable source of voltage. Model 711A is extremely compact, mounted in a rugged but lightweight wrap-around cabinet equipped with leather strap for easy portability. Its moderate price makes it an exceptional value in the power supply field.



712B REGULATED POWER SUPPLY



0.01% Regulation at 500 volts, 200 ma

THE new *hp*-712B Power Supply is deliberately designed to give you the finest performance obtainable plus broadest usefulness and the lowest price consistent with quality.

Model 712B provides four outputs for maximum applicability and has less than 50 millivolts change (no load to full load) at any regulated output voltage. Internal impedance is 0.1 ohm in series with 25 μ h maximum. Transient response is 0.1 milliseconds upon application of full load.

Uses

The new power supply meets the most demanding requirements of heavy duty laboratory or production work. It is particularly useful in powering pulse circuitry and other systems having high instantaneous current demands such as radar modulators; and in powering oscillators, small transmitters, complex systems and certain klystrons.

To insure long, trouble-free operation, the instrument uses sealed transformers and chokes, oil-filled condensers and is fully fused. Only the highest quality components are used, and no electrolytic condensers are employed.

Specifications

Output Voltages:

- Dc Regulated High Voltage: 0 to +500 (without switching), 200 ma max. load.
- Dc Regulated Fixed Bias: -300, 50 ma max load.
- Dc Variable Bias: 0 to -150, 5 ma max. load.
- Ac Unregulated: 6.3, CT, 10 amps max. load.

Regulation: (For line voltage $115 \pm 10\%$.)

- Dc Regulated High Voltage: Less than 50 millivolts change no-load to full-load at any output voltage. Less than 200 mv change at any voltage or current condition for $\pm 10\%$ line voltage variations.
- Dc Regulated Fixed Bias: Less than 50 millivolts change no-load to full-load.
- Dc Variable Bias: Regulated against line voltage changes. Internal impedance 0 to 10,000 ohms depending on bias control setting.

Ripple: Less than 500 microvolts.

Internal Impedance:

- Dc Regulated High Voltage: (For frequencies above 20 cps.) Full-load: 0.1 ohm in series with 25 μ h max. No-load: 1 ohm in series with 50 μ h max.

Recovery Time: Upon application of full-load: 0.1 millisecond max. Upon decrease from full-load to: (a) 0 ma, 0.5 millisecond max.; (b) 25 ma, 0.1 millisecond max. Maximum transient voltage, 1 volt.

Metering:

- Current Meter: 0 to 200 ma (high voltage only).
- Voltmeter: Three ranges, 0 to +500, 0 to +150 volts and 0 to -150 volts. Panel switch connects meter to dc regulated high voltage or dc variable bias and selects range.

Terminals: Either positive or negative dc regulated high voltage terminal may be grounded. Positive terminals of both bias supplies and negative terminal of dc regulated high voltage are common.

Overload Protection: Ac line, dc regulated high voltage, dc regulated fixed bias and filament supply are separately fused. Dc regulated high voltage drops to zero if bias fuse blows.

Power: 115 v ± 10 v, 50/60 cps, 450 watts.

Dimensions: Cabinet Mount: $20\frac{3}{4}$ " wide, $12\frac{1}{2}$ " high, 14" deep. Rack Mount: 19" wide, $10\frac{1}{2}$ " high, $14\frac{1}{8}$ " deep. Also can be used with *hp*-AC-17 End Frames.

Weight: Net 69 lbs. Shipping 108 lbs. (cabinet mount).

Data subject to change without notice.

hp 715A KLYSTRON POWER SUPPLY



Specifications

Supply No. 1: (Beam supply) Voltage range 250 to 400 volts; Max. current, 30 ma at 250 volts, 50 ma at 400 volts; regulation, approx. 1% from no load to full load at line voltages of $115\text{ v} \pm 10\%$; ripple, less than 7 mv; calibrated voltage controls provided.

Supply No. 2: (Reflector supply) Voltage range 0 to 900 volts; max. current, 10 microamperes; regulation, within 1% for line voltages of $115\text{ v} \pm 10\%$ for fixed currents; ripple, less than 10 mv; calibrated voltage controls provided.

Filament Supply: Provides 1.5 amperes max. at 6.3 volts ac $\pm 5\%$.

Modulation: Square wave modulation provided on supply No. 2; amplitude adjustable from 0 to 120 volts peak-to-peak. Square-wave rise and decay times less than 10 microseconds each; square wave frequency adjustable over ± 100 -cycle range from nominal 1,000 cps center frequency. FM modulation on supply No. 2: 60 cps sine wave adjustable 0 to 350 volts peak-to-peak.

External Modulation: Terminals and circuit provided for modulation from external source. Input impedance at external modulation terminals is approx. 100,000 ohms.

Trigger Voltage: During internal modulation, trigger voltage is supplied for synchronizing external equipment.

Power: 115/230 v $\pm 10\%$, 50/60 cps, 150 watts.

Dimensions: Cabinet Mount: $7\frac{1}{4}$ " wide, $11\frac{1}{4}$ " high, $13\frac{1}{2}$ " deep.

Weight: Net 18 lbs. Shipping 30 lbs. (cabinet mount).

Accessories Furnished: 1 715A-16C Cable Assembly (for connection to Klystron).

Accessories Available: AC-16A/B Cable Assembly.

Data subject to change without notice.

Versatile Power Source for Low-Power Klystrons

THE NEW -hp- 715A Power Supply was designed to meet the need for a compact, portable bench supply capable of operating many different types of low-power klystrons.

The Supply offers a regulated 250 to 400 volt beam voltage (continuously variable), a 0 to 900 volt regulated and continuously variable reflector supply and a 6.3 volt ac filament supply. The reflector supply can also be square-waved internally at the nominal frequency of 1,000 cps; and 60 cps FM modulation is provided on the reflector voltage.

To minimize the chance of accidental damage to a klystron, the instrument's reflector supply is arranged with a protective circuit preventing the reflector from becoming appreciably more positive than the resonator.



717A KLYSTRON POWER SUPPLY



New Power Source for Type 5721 and Similar Klystrons

THIS new instrument is designed specifically to power -hp- 670H Swept Frequency Oscillator, Type 5721 external cavity klystrons, and other klystrons having similar power requirements. It also has broad usefulness as a general purpose laboratory instrument.

Model 717A provides a high regulation beam supply of 800 to 1,000 volts at 25 milliamperes. The reflector supply is continuously variable from 0 to 600 volts in three ranges with wide overlap. The instrument furnishes grid voltage as well as filament potential for Type 5721 Klystrons.

Modulation may be applied to either the reflector or grid of the tube, and is available as a 60-cycle sine wave for FM with the reflector or as a square wave with repetition frequency continuously variable 400 to 1,000 cps. The internal square wave generator has rise and decay times of less than 10 μ sec. External modulating voltages may also be applied, and circuitry will pass external pulses as short as 3 μ sec with good wave shape.

A special output terminal operates the horizontal sweep circuit of an oscilloscope in synchronization with FM voltages applied to the klystron tube. A phase adjustment varies this voltage ± 45 degrees with respect to modulating potential to facilitate oscilloscope presentation.

Model 717A has a panel meter monitoring cathode current supplied to the klystron, and circuitry protecting the klystron by preventing the reflector from becoming excessively positive.

Specifications

Beam Supply:

Voltage Range: 800 to 1,000 volts.
Current: 25 ma maximum.

Regulation: (a) For constant load, less than $\pm 0.1\%$ output voltage change for line voltage variations of nominal value $\pm 10\%$ (103 to 127 volts).

(b) For line voltage of nominal value $\pm 10\%$, less than $\pm 1\%$ output voltage change for output currents from 0 to 25 ma.
Hum: Less than 10 millivolts.

Reflector Supply:

Voltage Range: 0 to 600 volts in 3 ranges: 0-300, 200-400, 300-600 v.

Current: 1 ma maximum.

Regulation: For constant load, less than $\pm 0.05\%$ for line voltage variations of nominal value $\pm 10\%$ (103 to 127 volts).

Hum: Less than 10 millivolts.

Square Wave Modulation: (a) Amplitude adjustable 0 to 60 volts, peak-to-peak.

(b) Rise and decay times less than 10 μ sec.

(c) Frequency adjustable 400 to 1,000 cps.

Sine Wave Modulation for FM'ing: (a) Amplitude adjustable 0 to 300 volts, peak-to-peak.

(b) Frequency: line voltage frequency.

(c) Oscilloscope horizontal sweep voltage: 15 volts, peak-to-peak, phase adjustable $\pm 45^\circ$ with respect to modulating voltage.

External: Terminals for external modulating voltage. System will pass 3 μ sec pulses.

Grid Supply:

Voltage Range: 0 to 30 volts open circuit.

Square Wave Modulation: (a) Amplitude adjustable 0 to 60 volts, peak-to-peak.

(b) Rise and decay times less than 10 μ sec.

(c) Frequency adjustable 400 to 1,000 cps.

External: Terminals available for applying external modulating voltage. System will pass 3 μ sec pulses.

Filament Supply: 6.3 volts ac, 2 amps.

Power: 115/230 v $\pm 10\%$, 50/60 cps, 150 watts.

Dimensions: Cabinet Mount: 7" wide, 10 $\frac{3}{4}$ " high, 18" deep.

Weight: Net 34 lbs. Shipping 85 lbs.

Accessories Furnished: 1 717A-16C Output Cable Assembly.

Accessories Available: AC-16B/K Cable Assembly.

Data subject to change without notice.

MICROWAVE EQUIPMENT FOR WAVEGUIDE AND COAXIAL SYSTEMS



HEWLETT-PACKARD microwave test equipment is designed to provide a complete set of high-quality, low-cost instruments for measurement of microwave parameters including power, impedance, attenuation, frequency. In addition to a wide variety of coaxial slotted lines, bridges, detectors, mounts, etc., the equipment includes complete instrumentation in the waveguide field. Each instrument has been designed for broad band coverage, high stability, broadest applicability, convenient size, and simplest possible operation. Highest quality metals, alloys, components and insulation have been used in construction; and utmost care is taken during manufacture. All units are thoroughly tested before leaving the factory and are warranted to conform with, or exceed, specifications.

General information concerning use and application of *-hp-* microwave equipment is presented on the following pages and on pages 89, 90, 95, 96, and 97. Details of *-hp-* microwave instruments, themselves, begin on page 85. *-hp-* Signal Generators for microwave use are shown separately in a section beginning on page 63 of this Catalog.

Letter Designations

Model Numbers of *-hp-* waveguide components are normally preceded by a prefix letter. This letter designates the waveguide size and frequency band of the instrument. Each *-hp-* waveguide instrument of a given band will have this same prefix in its model number. Six designator prefixes are used:

"S"	3" x 1½"	2.6 to 3.95 KMC
"G"	2" x 1"	3.95 to 5.85 KMC
"C"	1.718" x 0.923"	4.9 to 7.05 KMC
"J"	1½" x ¾"	5.3 to 8.2 KMC
"H"	1¼" x ⅝"	7.05 to 10.0 KMC
"X"	1" x ½"	8.2 to 12.4 KMC
"P"	.702" x .391"	12.4 to 18.0 KMC

Thus, an *-hp-* 370 Fixed Waveguide Attenuator designed for use with 3" x 1½" guide is designated S370. The same instrument designed for the .702" x .391" guide is designated P370.

Many Hewlett-Packard instruments also have suffix letters in the complete model number. Normally the letter immediately following the

model numbers indicates a new, modified or special version of a basic model. Thus, *-hp-* 430C Microwave Power Meter is the latest version of *-hp-* 430A Microwave Power Meter (the original instrument in its classification).

However, in the case of certain *-hp-* microwave elements, the *suffix* letter indicates specific attenuation or coupling factors. Again, six designator letters are used:

"A"	3 db	"D"	20 db
"B"	6 db	"E"	30 db
"C"	10 db	"F"	40 db

Thus, the 20 db coupling version of *-hp-* 750 Cross-Guide Coupler will be designated as *-hp-* 750D.

The Model of the 750 built for 1" x ½" waveguide systems will, of course, have the size *prefix* designator "X". Therefore, the complete model number of a 750 series Coupler with 20 db coupling for use with 1" x ½" equipment is *-hp-* X750D Cross-Guide Coupler. Use of this prefix and suffix code will simplify and speed inquiries and ordering.

Flanges

All *-hp-* waveguide equipment is equipped with plain AN cover flanges. When it is desired to connect between Hewlett-Packard instruments and a choke flange system, *-hp-* Model 290A Cover to Choke Flange Adapters (page 85) should be used.

Finishes

-hp- waveguide elements are finished outside in grey, baked enamel. Conducting surfaces are plated with a bright, high-conductivity alloy, except when stated otherwise.

Waveguide Equipment

Hewlett-Packard Broad Band Waveguide Instruments are based on an entirely new design approach. The fundamentals of this new concept are:

1. Each instrument is of simplest construction consistent with its basic function and covers the entire frequency range of its waveguide size.
2. An integrated set of instruments is available for each commonly-used waveguide frequency from S to P band.
3. New, simple mechanical design, incorporating novel electrical circu-

ity, insures high accuracy, stability, and quality; and yet makes possible quantity production at low cost.

With new *-hp-* waveguide equipment, you select the exact instruments you need. Each is designed in its most fundamental form, yet is integrated mechanically and electrically with the complete *-hp-* waveguide line. You are assured maximum operating flexibility, efficiency, convenience, and economy.

Power, Impedance Measurements

General information and techniques for the use of Hewlett-Packard microwave test equipment in making power measurements are presented on pages 89 and 90. A similar discussion concerning microwave impedance measurements appears on pages 95, 96 and 97. Instruments appropriate to each type of measurement are shown on the pages immediately following the discussion of that type of measurement.

Attenuation Measurement

Attenuation measurements are usually made by a substitution or modified substitution method. A set-up for substitution measurement is shown in Figure 1(A). Here the signal source is connected to a detector mount through a length of lossless transmission system in which place the attenuator pad may be substituted. A reading is obtained on the output indicator with a section of lossless line in the circuit. The lossless line is then replaced by the attenuator pad being measured. The power attenuation at the output indicator is a measure of the pad attenuation. This measurement requires first, that the law of the detector be

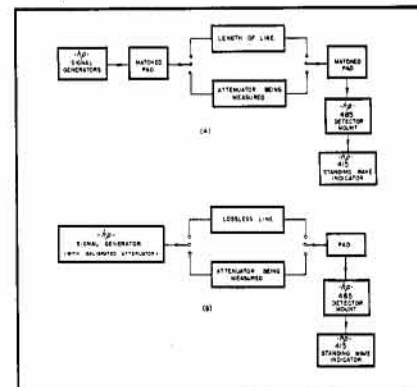

Figure 1(A) and 1(B): Set-up for measuring attenuators.

known over the complete frequency range of the measurement; and second, that reflection effects in the system be essentially the same both with and without the pad.

The type of detecting equipment used will depend on the range of the attenuation measurement. A power monitoring combination such as -hp-430C Microwave Power Meter and a bolometer mount will allow attenuation measurement over approximately 20 db. A wider range of attenuation, up to 30 to 40 db, can be achieved with a detector mount employing a barretter, and -hp-415B Standing Wave Indicator (high sensitivity, tuned voltmeter). In this case, the signal source must be modulated, and the rf power level must be kept below 200 microwatts for square law detector characteristics. The attenuation in decibels may be read directly from the Model 415B.

For even greater ranges of attenuation (such as checking the calibration of a piston attenuator) a linear receiver may be substituted for the detector. The output of the receiver's second detector should be connected to a tuned voltmeter, such as -hp-415B, to eliminate errors such as distortion present in the receiver's audio system. -hp-415B is calibrated on the basis of a square law detector, and when it is used with a linear detector, the db readings will be one-half the correct value.

To eliminate effects of reflections between generator and attenuator, and attenuator and load, it is desirable to use pads. Pads should be well matched to the transmission system.

An additional method of measuring attenuators is shown in Figure 1(B). This method is particularly applicable when signal generators with accurately calibrated attenuators are available. In this set-up, the output of the signal source is fed through an accurately calibrated attenuator to the attenuator being measured and then into the load or detector. The attenuator being measured is removed, and a reading is obtained upon the detector. The setting of the signal generator attenuator is noted. The attenuator is then inserted, and the signal generator output is adjusted to obtain the same output reading as before. The difference between the signal generator attenuator settings is the attenuation of the attenuator in db. Since the detector is always operated at the same level, detector law is no problem. The attenuator measurement may similarly be performed with -hp-382A Precision Attenuator.

Cable Characteristics

Two cable characteristics that frequently must be measured are attenuation and characteristic impedance. The following discussion indicates appropriate procedures for these measurements.

Large Values. The measurement of large values of cable attenuation can be made as shown in Figure 1B. The amount of attenuation for a given length of cable is measured in the same manner as described in the foregoing discussion of attenuation measurement.

Small Values. The measurement of small values of cable attenuation requires a different technique. In this case, attenuation is calculated by measuring SWR of a shorted cable and substituting into a formula which relates SWR, cable length and attenuation. A recommended arrangement for this measurement is shown in Figure 2.

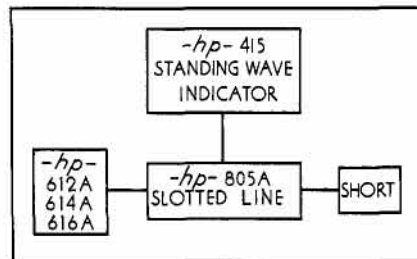

Figure 2. Suggested instrument arrangement for measuring small values of cable attenuation. Unknown cable is placed between slotted line and short.

In measurements on 50 ohm coaxial cable with this instrumentation, the procedure is as follows:

1. Measure cable length.
2. Measure SWR of shorted cable.
3. Compute attenuation from this formula:

$$\text{Tanh } \alpha L = \frac{1}{\text{SWR}} \text{ Nepers}$$

If αL is much smaller than 1, $\text{Tanh } \alpha L$ is approximately αL , and this formula reduces to

$$\alpha L = \frac{1}{\text{SWR}} \text{ Nepers or } \frac{8.686}{\text{SWR}} \text{ db}$$

For cables with a characteristic impedance of other than 50 ohms, a special technique must be employed which is beyond the scope of this discussion. See Terman & Pettit, "Electronic Measurements," 2nd edition, page 189.

Characteristic Impedance

The value of the characteristic impedance of a cable can be computed from impedance measurements made with a bridge such as -hp-803A VHF Bridge (page 100). Suggested procedure is as follows:

At some specific frequency, measure the input impedance to the line with the receiving end of the line open. At the same frequency, measure the input impedance of the line with the receiv-

ing end shorted. Then compute the characteristic impedance with the formula:

$$Z_0 = \sqrt{\frac{Z_s(\text{op}) \cdot Z_s(\text{sh})}{Z_s(\text{op})}}$$

where Z_0 = characteristic impedance
 $Z_s(\text{op})$ = sending end impedance with receiver end open
 $Z_s(\text{sh})$ = sending end impedance with receiver end shorted

(Reference: Skilling, "Electric Transmission Lines," 1951, page 163.)

Another useful method of determining characteristic impedance in a coaxial cable is through the measurements of two constants of the cable—capacitance and velocity of propagation. The characteristic impedance is then computed as follows:

$$Z_0 = \frac{101,000}{\sqrt{VC}}$$

where Z_0 = characteristic impedance
 V = velocity of propagation
 C = capacity in $\mu\text{mf}/\text{foot}$

The suggested procedure is as follows:

1. Measure cable capacitance at low frequencies with a standard capacitance bridge.
2. Measure velocity of propagation at some frequency (above 50 MC to prevent "skin effect" errors).

Figure 3 indicates equipment appropriate to the measurement of velocity of propagation.

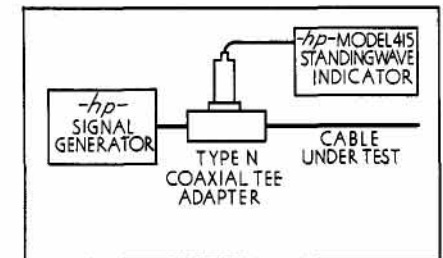

Figure 3. Arrangement of instruments for measuring velocity of propagation.

To measure velocity of propagation,

- a. Vary frequency of the signal generator to obtain successive nulls on the standing wave indicator. Record frequencies of the nulls, f_1 and f_2 .
- b. Measure length of the cable in feet to the center of the tee connector.
- c. Compute velocity of propagation from the formula:

$$V = \frac{L f_1}{2.46K}$$

where L = cable length in feet
 f_1 = recorded frequency
 $K = \frac{2f_1}{f_2 - f_1}$

3. Substitute the values of capacitance and velocity of propagation in the formula:

$$Z_0 = \frac{101,000}{\sqrt{VC}} = \text{characteristic impedance}$$

(See Terman & Pettit, "Electronic Measurements," 2nd edition, page 135.)

hp 281A/290A ADAPTERS

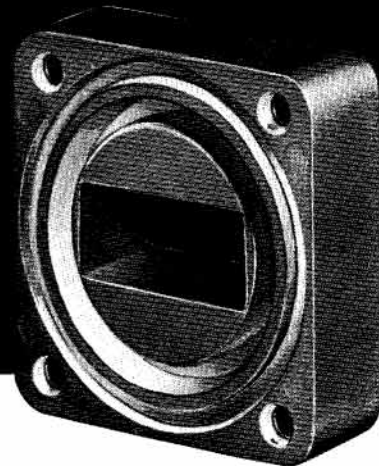
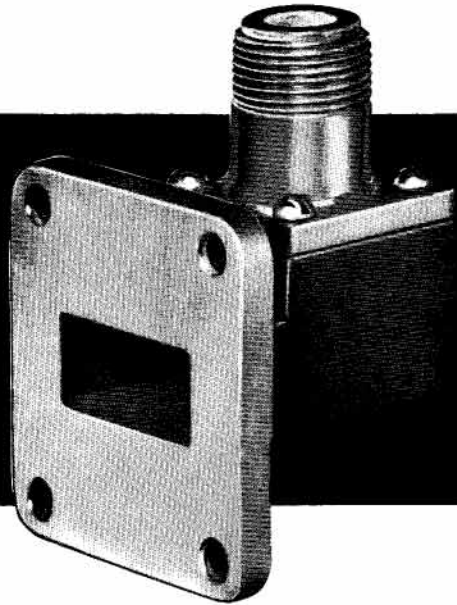

-hp- 281A Waveguide to Coaxial

These adapters provide a convenient means of transmission between waveguide and coaxial systems. Power may be fed in either direction, and each adapter covers the full frequency range of its waveguide size with SWR of less than 1.25. These instruments use a probe with a low-loss dielectric sheath to transform waveguide impedance into coaxial cable impedance. They are fitted with a standard Type N plug connecting to a coaxial cable and a plain AN flange for connection to waveguide.

-hp- 290A Cover to Choke Flange

These instruments consist of a short waveguide section with a plain AN cover flange on one end and a choke flange on the other. They provide an efficient connection between -hp- waveguide equipment and choke flange equipment; they may also be used as a choke mounted on a test instrument flange. (All -hp- waveguide equipment is provided with plain AN flanges.)

Specifications

-hp- 281A Adapters		-hp- 290A Adapters				Frequency Range KMC	Waveguide Size (in.)
Model	Length (in.)	Model	Cover Flange	Choke Flange	Length (in.)		
S281A	3 $\frac{3}{4}$	S290A	UG53/U	UG54A/U	3	2.60 - 3.95	3 x 1 $\frac{1}{2}$
G281A	2 $\frac{5}{8}$	G290A	UG149A/U	UG148B/U	2	3.95 - 5.85	2 x 1
J281A*	2	J290	UG344/U	UG343A/U	1 $\frac{3}{4}$	5.30 - 8.20	1 $\frac{1}{2}$ x $\frac{3}{4}$
H281A	1 $\frac{3}{4}$	H290A	UG51/U	UG52A/U	1 $\frac{1}{2}$	7.05 - 10.00	1 $\frac{1}{4}$ x $\frac{5}{8}$
X281A	1 $\frac{5}{8}$	X290A	UG39/U	UG40A/U	$\frac{1}{2}$	8.20 - 12.40	1 x $\frac{1}{2}$
		P290A	UG419/U	UG541/U	1 $\frac{1}{8}$	12.40 - 18.00	.702 x .391

*SWR 1.30 from 5.3 to 5.5 KMC; other models 1.25.

Data subject to change without notice.

hp 360 LOW PASS FILTERS

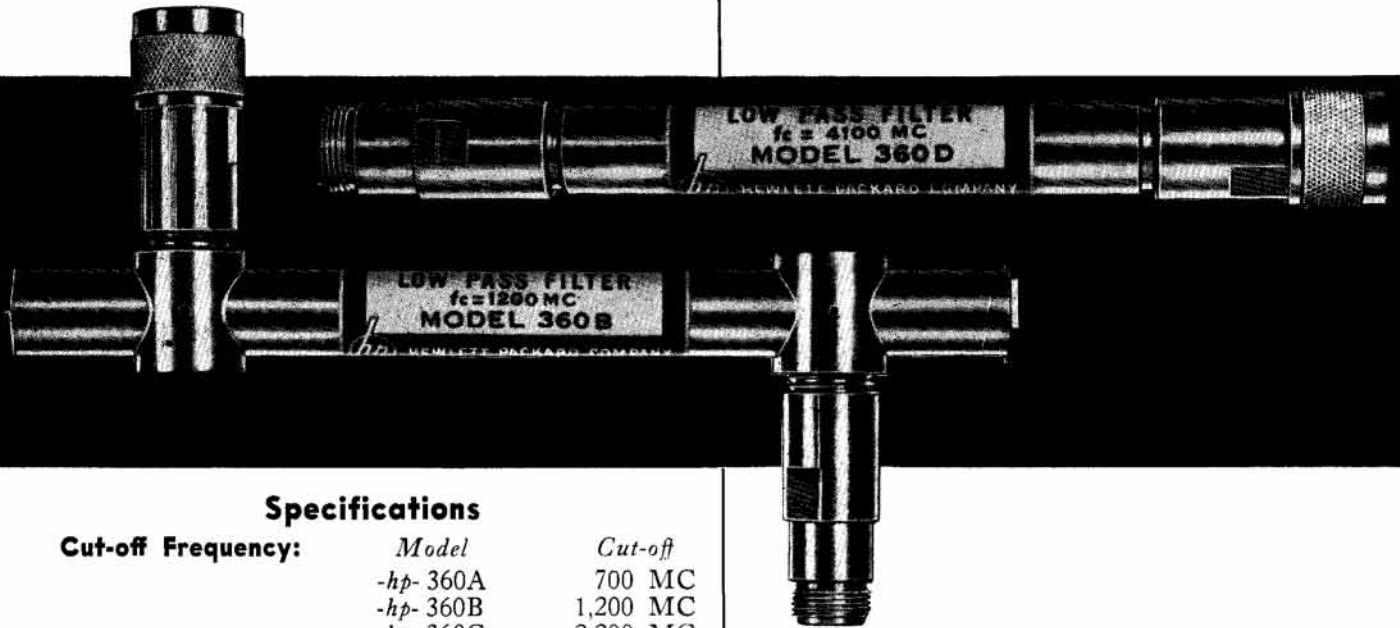

Specifications

Cut-off Frequency:	Model	Cut-off
	-hp- 360A	700 MC
	-hp- 360B	1,200 MC
	-hp- 360C	2,200 MC
	-hp- 360D	4,100 MC

Insertion Loss: Not over 3 db throughout pass band.

Rejection: 50 db or more attenuation at 1.25 x (Cut-off Frequency).

Nominal Impedance: 50 ohms through pass band. Should be matched for optimum performance.

Physical Dimensions:

Model No.	360A	360B	360C	360D
Length Overall	10 7/8"	7 7/32"	10 25/32"	7 3/8"
Outer Diameter	5/8"	5/8"	5/8"	5/8"
Center Line to Male End	2 5/16"	2 5/16"		
Center Line to Female End	2 1/4"	2 1/4"		

Accessories Available: AC-16F rf Cable Assembly; AC-16C rf Cable Assembly.

Fittings: 1 Type N Male (UG 21/U) ; 1 Type N Female (UG 23/U)

Data subject to change without notice.

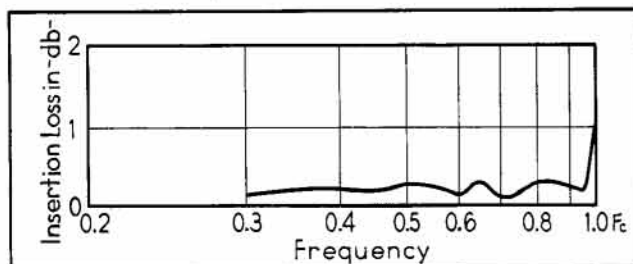

Figure 1. Typical band pass characteristics.

Eliminate Harmonics. Transmit Energy at a Single Frequency

MODEL 360 Low Pass Filters are designed to facilitate microwave measurements by eliminating harmonics and permitting the transmission of energy at a single known frequency. Such isolation of a single frequency is of particular importance in the making of slotted line measurements, in checking filter characteristics, in determining receiver response and other applications where harmonics are objectionable.

No Spurious Responses

These -hp- filters consist of brass tubes fitted with a multi-section coaxial type filter. The ends are terminated in Type N fittings, one male and one female. Attenuation in the pass bands less than 3 db; and attenuation in the rejection band is more than 50 db. There are no spurious responses up to 3 times cutoff frequency.

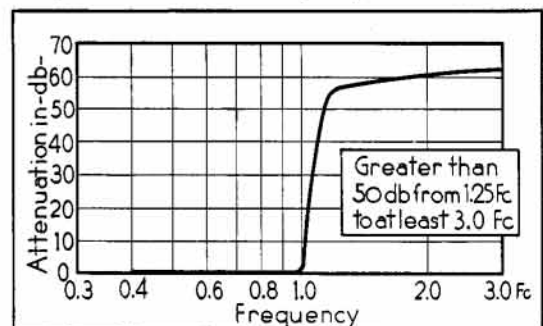
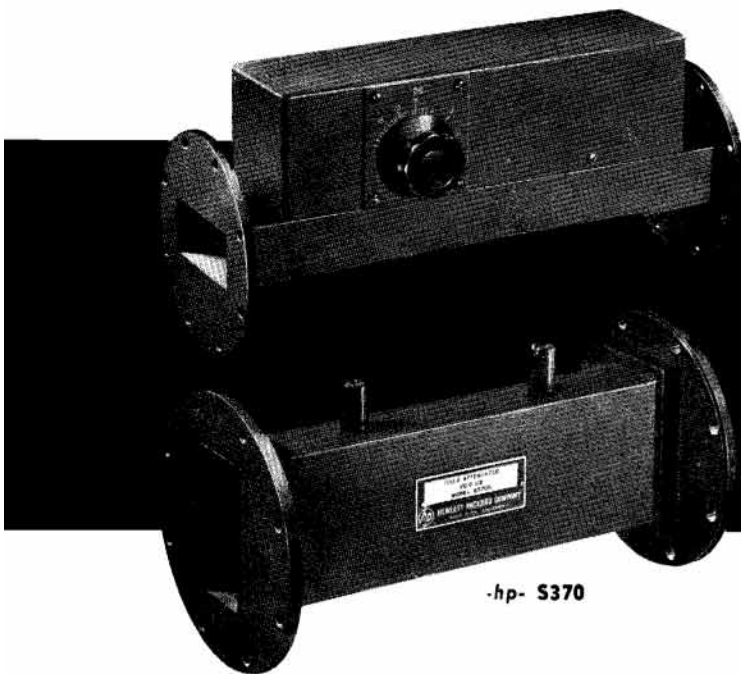

Figure 2. Typical rejection characteristics.

hp 370/375/380 WAVEGUIDE ATTENUATORS



-hp- S370

-hp- 370 Fixed Waveguide Attenuators

These attenuators are waveguide sections providing fixed amounts of attenuation. They are useful in reducing power flowing in a waveguide system, reducing reflection of loads or sources, or isolating parts of a waveguide system. The instruments consist of a rectangular waveguide in which a strip of resistive material is mounted. Position of the strip is factory-adjusted to give an exact attenuation value at mid-frequency of the waveguide band. Model 370 handles power to a 1 kw peak, 1 watt average. Attenuation of 6, 10 and 20 db is offered, accurate to within ± 0.2 db. Maximum SWR is 1.15 over the full band width. Frequency sensitivity is less than 20% of nominal attenuation value in db, full frequency range. -hp- J370, $\pm 20\%$ from 5.85 to 8.20 KMC; $\pm 25\%$ from 5.30 to 5.85 KMC.

-hp- 375A Variable Flap Attenuators

Variable flap attenuators provide a simple, convenient means of adjusting waveguide power level, or isolating source and load. They consist of a single slotted section in which a matched resistive strip is inserted a variable amount. The degree of strip penetration determines attenuation. A dial shows average reading over the frequency band, and a dust cover with shielded braid reduces external radiation and eliminates hand capacity effects.

Model 375 Attenuators have a maximum SWR of less than 1.15 over the guide frequency range. Attenuation is variable 0 to 20 db; the equipment dissipates average power of 1 watt (except small waveguides where maximum dissipation is 0.5 watts). Dial calibration is accurate within ± 1 db from 0 to 10 db, ± 2 db from 10 to 20 db.

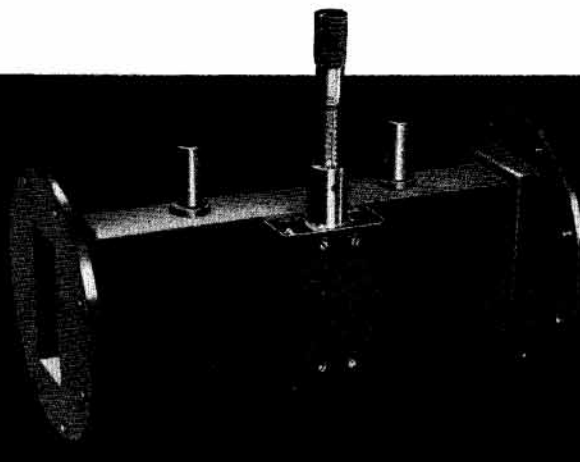

-hp- S380A Calibrated Variable Attenuator

Here is a convenient, efficient instrument for setting exact power level or measuring attenuation in a waveguide system. The equipment consists of a waveguide section with an attenuating plate parallel to the narrow face of the waveguide. A micrometer adjustment moves the plate across the waveguide, increasing attenuation from 0 to 10 db as the plate nears the center of the guide. Maximum average power is 1 watt; peak power level is 1 kilowatt.

Specifications S380A: Frequency range 2.60 to 3.95 KMC. Waveguide size 3" x 1 1/2". Maximum attenuation 10 db. Insertion loss less than 0.5 db. SWR 1.15. Power dissipation 1 watt. Calibration frequency 3.0 KMC. Calibration accuracy 0.3 db. Calibration for other frequencies available on request.

Specifications, -hp- 370, 375 Attenuators

-hp- Model 370*				-hp- Model 375A			Frequency Range KMC	Waveguide Size (in.)
Model	Calib. Freq. KMC	Power Dissipation Watts	Length (in.)	Model	Power Dissipation Watts	Length (in.)		
S370	3.0	1.0	12	S375A	1.0	14 1/4	2.60 - 3.95	3 x 1 1/2
G370	4.5	1.0	10 1/8	G375A	1.0	13	3.95 - 5.85	2 x 1
J370	7.0	1.0	7 3/8	J375A	1.0	13	5.30 - 8.20	1 1/2 x 3/4
H370	8.6	1.0	6 3/8	H375A	1.0	7 1/4	7.05 - 10.00	1 1/4 x 5/8
X370	10.0	1.0	5 1/4	X375A	0.5	7 3/8	8.20 - 12.40	1 x 1/2
P370	15.0	1.0	4 1/8	P375A	0.5	7 1/4	12.40 - 18.00	.702 x .391

Maximum SWR 1.15 for all models. (*Note: Model number suffix indicates db attenuation of 370 series attenuators. Suffix "B", 6 db. Suffix "C", 10 db. Suffix "D", 20 db. Example: Model G370B is a 6 db attenuator for the 3.95 to 5.85 frequency range.)

Data subject to change without notice.



382A PRECISION ATTENUATORS



Specifications

Model	Maximum Dissipation Watts	Length (in.)	Frequency KMC	Waveguide Size (in.)
J382A	10	25	5.30 - 8.2	1 1/2 x 3/4
H382A	10	19 7/8	7.0 - 10.0	1 1/4 x 5/8
X382A	10	15 1/2	8.2 - 12.4	1 x 1/2
P382A	5	12 1/8	12.4 - 18.0	.702 x .391

SWR is less than 1.15 for all models. Calibrated range 0-50 db. Attenuation at zero setting less than 1 db. Calibration accuracy plus frequency deviation is $\pm 2\%$ of reading in db, or 0.1 db, whichever is greater. Includes calibration error plus frequency error.

Variation in phase shift is less than 1° for all values of attenuation up to 40 db.

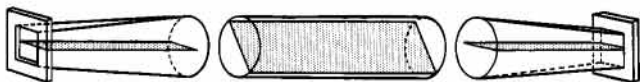

Figure 1. Cutaway shows relationship of fixed films (in waveguide extensions) and rotating film (center).

Data subject to change without notice.

Radical New Design Measures Directly, Accurately, 0 to 50 db

THIS revolutionary new waveguide attenuator provides the convenience of direct readings and a high order of measuring accuracy never before found in commercial attenuators.

Model 382 attenuates from 0 to 50 db, full range, independently of frequency. Phase shift is constant with attenuation. Accuracy is within $\pm 2\%$ of db reading. Power handling capacity is high. The instrument is set and read directly on a large easily read dial without interpolation or charts.

The secret of the reliability and accuracy of this instrument is that attenuation depends on angular position of the attenuating film rather than specific resistivity. The attenuator uses three resistive films—two mounted in the same plane and the third rotatable axially in the center section. (Figure 1.) When all films are in the same plane, there is no attenuation. Rotation of the center film increases attenuation proportional to the cosine squared of the angle of rotation.

POWER MEASUREMENT

IN THE microwave region, power measurements are considered to be more basic than current or voltage measurements. This is because power is invariant with position of measurement, while current and voltage (because of the distributed nature of the transmission system at these frequencies) are not.

The measurement of power is accomplished by means of a bolometer which changes the rf energy into heat energy. This causes the resistance of

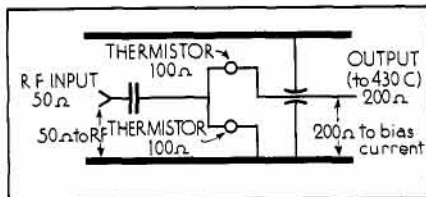

Fig. 1. Arrangement for using two thermistors in coaxial systems (-hp- 477A Coaxial Thermistor Mount).

the bolometer to change. The resistance change is measured and used to determine the rf energy.

Bolometers used for microwave measurements are of two general types—metallic wire or film in which the temperature coefficient of resistance is positive, and thermistors in which it is negative. Both barretters and instrument fuses are used as positive

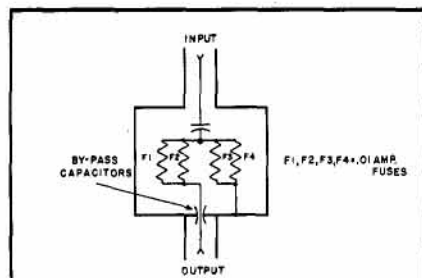

Fig. 2. Arrangement for using four instrument fuses in series parallel combination in -hp- 476A.

temperature coefficient bolometers. Barretters consist of a short length of very fine platinum wire suitably encapsulated. Negative temperature coeffi-

cient bolometers (thermistors) consist of a small bit of semi-conductive material suspended between two fine wires. They may or may not be encapsulated.

In general, barretters are delicate, and readily burned out by too much power. Even if the overload is insufficient to burn out a barretter, it may still increase its cold resistance to the point where a self-balancing bridge meter cannot be zero set. Thermistors are much more rugged. Although they are rated at 25 mw maximum, they generally burn out at about 400 mw or more, and their characteristics change only slightly, if at all, upon overload.

The bolometer element is used in conjunction with a power meter such as the -hp- Model 430C. This power meter is designed to operate with bolometer impedances of either 100 or 200 ohms.

The bolometer element itself must be mounted and well matched to the transmission system used and to the power meter. -hp- bolometer mounts are available for coaxial and waveguide systems with a low SWR through their operating range. Barretters are usually operated at 200 ohms, while thermistors usually operate at 100 or 200 ohm levels. Unique series-parallel combinations of the bolometer element are used in -hp- coaxial mounts. -hp- 477A Coaxial Thermistor Mount, for example, uses two thermistor elements which present 200 ohms to a microwave power meter but reflect 50 ohms to the rf energy. (Figure 1.)

The power measured by a bolometer mount also depends upon the relationship between the load and the source impedance. In order to obtain maximum available power the load should present a conjugate match to source impedance. This can be achieved by properly adjusting a double-stub tuner, a stub-line stretcher, an E-H tuner, or a slide-screw tuner. These tuners

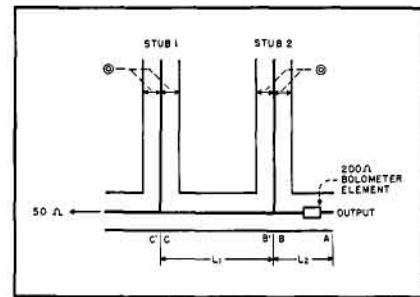

Fig. 3. Diagram of Tunable Bolometer Mount (-hp- 475A).

transform the magnitude and phase of the source impedance in order to conjugate match it to the load impedance. -hp- Model 475B Tunable Bolometer Mount operates on this principle. Errors that result from generator and load mismatch have been discussed under the section of this catalog dealing with Signal Generators. Such errors, however, are generally small and may usually be disregarded.

-hp- 430C Microwave Power Meter will give direct instantaneous readings of microwave power when connected with a suitable bolometer mount. The bias current necessary to bring the bolometer to the correct operating resistance is furnished by the 430C Power Meter. This power meter circuit includes a self-balancing bridge and an audio voltmeter to indicate the magni-

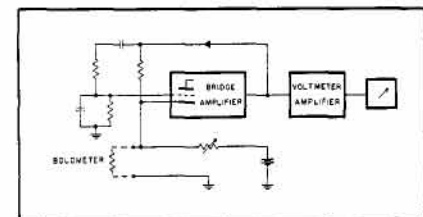

Fig. 4. Basic Circuit of Power Meter.

tude of the bridge amplifier output, (Figure 4). The self-balancing bridge uses the external bolometer element (a non-linear resistor) as one of the bridge arms. A high gain amplifier is connected across the bridge as a detector, and the output of the same am-

pplier is connected as the driving source for the bridge. Then there being sufficient gain, the circuit oscillates at an amplitude such that the bridge is balanced. When the rf power is applied to the element, the amplitude of oscillation decreases the amount necessary to maintain the element's resistance constant. This power decrease is equal to that power added by the rf source and can be read on the voltmeter which is calibrated in power units.

-hp- bolometer mounts have been designed for both coaxial and waveguide systems at frequencies between 10 MC and 12.5 KMC. These mounts are extremely simple to use, have low SWR, and may be used with -hp- 430C Power Meter to provide direct reading measurements. -hp- bolometer mounts may be classified according to the type

Model 485B Detector Mounts employ a single tuning control to match the applicable waveguide to a bolometer element (barretter or crystal). In general, their SWR is less than 1.25 over the rated frequency range.

-hp- 476A Universal Bolometer Mount is a fixed tuned bolometer in the frequency range from 10 to 1,000 MC. The bolometer element consists of 1/100 ampere fuses. -hp- 475B is a double stub tuner matching 50 ohm coaxial systems into 100 or 200 ohm bolometers. It covers a frequency range of 1,000 to 4,000 MC, for extremely accurate microwave power measurements.

In general, square-wave or pulse modulated power can be measured accurately with either a barretter, fuse, or thermistor, subject to certain limita-

to avoid modulating frequencies approaching the bridge frequency (10.6 KC) or its sub-multiples. At pulse frequencies near sub-multiples of the 10.6 KC, beats are produced which show on the meter. At modulation frequencies which are exact sub-multiples of the oscillator frequency, the oscillator may lock in with the modulation frequency causing the meter pointer to dip to a low value. In either case, the effect can be avoided by changing the repetition frequency slightly. This solution can be used down to frequencies at least as low as 200 cps.

A tabulation of -hp- equipment to be used with Model 430C Power Meter for a specific transmission system, frequency range and power level is given in Figure 5.

Power levels greater than the highest range of the 430C Power Meter can be measured by attenuating the power by pads or by directional couplers to the range of the Model 430C.

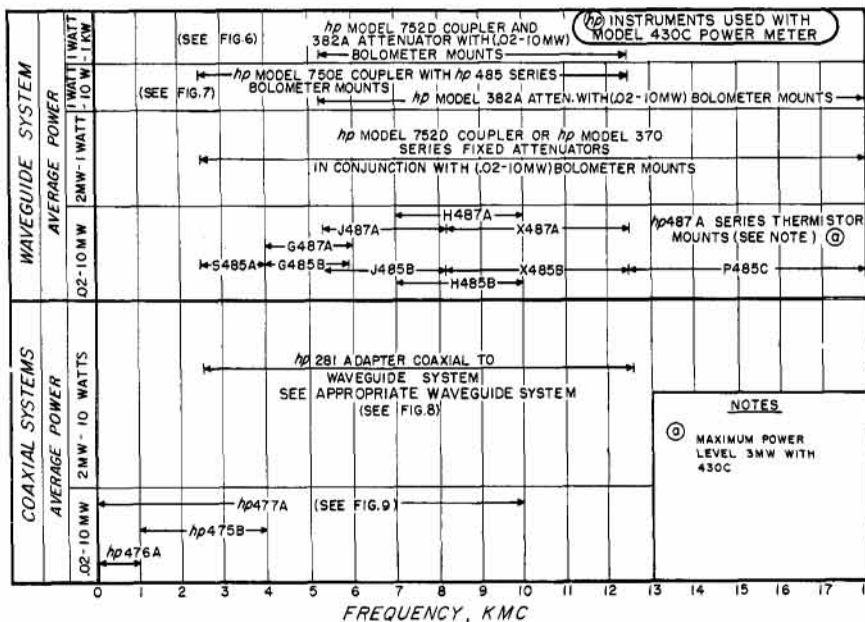

Fig. 5. -hp- equipment for use with -hp- 430C Microwave Power Meter.

of bolometer element employed, namely, fixed tuned thermistor mounts, detector mounts (barretters and crystals), and universal and tunable bolometer mounts.

New -hp- fixed tuned thermistor mounts are exceptionally broad band bolometers. Model 477A Coaxial Thermistor Mount covers the frequency range of 10 MC to 10 KMC, while -hp- 487A (waveguide series) are available from 3.95 to 12.4 KMC. No tuning is required and an extremely low SWR is maintained throughout frequency bands.

tions which depend upon the characteristics of the bolometer elements in conjunction with the bridge oscillator. However, in -hp- 430C Power Meter, these limitations are not serious.

When used with barretters or fuses, precautions should be taken if the modulation frequency is below about 200 cps. For sine and square-wave modulated power, the meter reading will tend to increase at such low modulating frequencies. For use with thermistor, precautions should be taken for frequencies less than 100 cps.

Furthermore, care should be taken

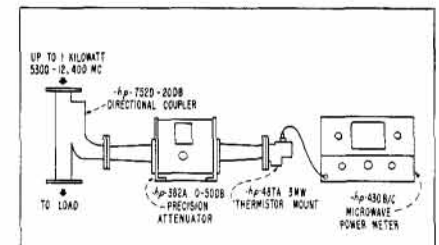

Fig. 6. Arrangement for measuring average power from 1 watt to 1 kilowatt in waveguide system.

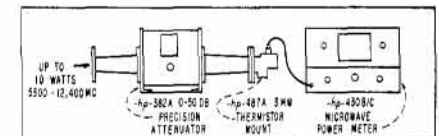

Fig. 7. Arrangement for measuring average power from 1 to 10 watts in waveguide system.

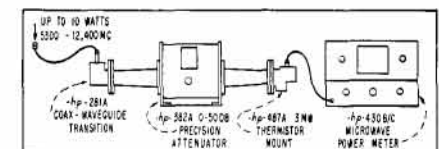

Fig. 8. Arrangement for measuring average power to 10 watts in coaxial systems.

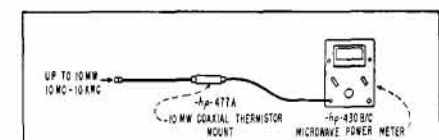

Fig. 9. Arrangement for measuring average power up to 10 milliwatts in coaxial systems.

hp 430C MICROWAVE POWER METER



Specifications

Power Range: 5 ranges, front panel selector. Full scale readings of .1, .3, 1, 3 and 10 mw. Also continuous readings from -20 to $+10$ dbm. (0 dbm = .001 watt). Power range may be extended with attenuators or directional couplers in microwave system.

External Bolometer: Frequency range depends on bolometer mount. Bolometers can operate at resistance levels of 100 or 200 ohms and can have positive or negative temperature coefficients. Any dc bias current up to 16 ma is available for biasing positive or negative temperature coefficient bolometers. Dc bias current is continuously adjustable and independent of bolometer resistance and power level range.

Suitable bolometers are:

Instrument fuses: *-hp-* G-28A 1/100 amp fuse:

Barretters: Sperry 821, Narda N821B or N610B, PRD 610A, 614, 617 or 631C.

Thermistors: W. E. D166382 and 32A3, V. E. Co. 32A3, 32A5, Narda 333, 334.

Accuracy: $\pm 5\%$ of full scale reading.

Power: 115/230 v $\pm 10\%$, 50/1,000 cps, 75 watts.

Dimensions: Cabinet Mount: $7\frac{3}{8}$ " wide, $11\frac{1}{2}$ " high, $12\frac{1}{4}$ " deep. Rack Mount: 19" wide, 7" high, $12\frac{1}{2}$ " deep.

Weight: Net 20 lbs. Shipping 32 lbs. (cabinet mount).

Accessories Furnished: 1 AC-16D Cable Assembly.

Accessories Available: AC-16K Video Cable Assembly.

Data subject to change without notice.

Direct, Automatic, Instantaneous Pulsed or CW Power Readings

THIS NEW *-hp-* Microwave Power Meter gives you instantaneous rf power readings direct in db or mw—and completely eliminates tedious computation and troublesome adjustments during operation. The instrument may be used at any frequency for which there are bolometer mounts—and measurements are entirely automatic.

In measuring CW power, *-hp-* 430C uses either an instrument fuse, barretter or thermistor as a bolometer element. CW or pulsed power may be measured using either a negative or positive temperature coefficient element at 100 or 200 ohm levels. Power is read direct in milliwatts, .02 to 10 mw, or in dbm from -20 to $+10$. Higher powers may be measured by adding attenuators such as *-hp-* 370 and 380 series (see page 87) to the system. Directional couplers such as *-hp-* 750 or *-hp-* 752 may also be used to sample energy. (See pages 108, 109.)

-hp- 430C consists of an audio bridge, one arm of which is a power-sensitive element. The bridge is initially balanced with no rf power in the element. As rf power is applied, the equivalent in audio power is automatically removed, so the bridge remains in balance. The change in audio power level indicates directly on a VTVM calibrated to show rf power in the sensitive bridge arm.



475B TUNABLE BOLOMETER MOUNT

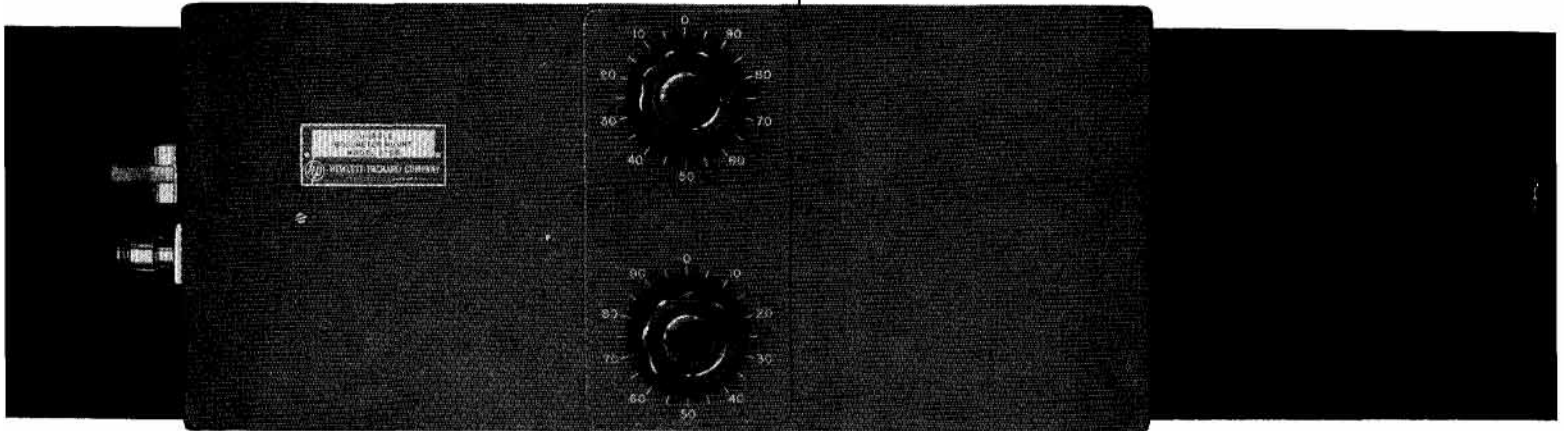

Specifications

-hp- 475B

Frequency: Approx. 1,000 to 4,000 MC. (Varies with SWR, phase of source and value of bolometer load.)

Fittings: Type N female, (UG23/U) for incoming power; BNC Type (UG89/U) for bolometer dc connection. Type N connector fitting supplied to replace BNC connector, so mount may be used as a conventional double-stub transformer.

Power Range: 0.1 mw to 10 mw full scale (with -hp- 430B/C).

Power Sensitive Element: (Not furnished) Specially selected 1/100-ampere instrument fuse (-hp- G-28A), Sperry 821 or Narda N821 barretter; Western Electric Type D166382 thermistor.

Dimensions: Cabinet Mount: 7 $\frac{3}{8}$ " wide, 18" long, 3 $\frac{5}{8}$ " deep.

Accessories Furnished: 2 475B-34V Barretter Adapters; 1 UG21/U Type "N" Male Connector.

Accessories Available: AC-16F rf Cable Assembly; AC-16K Video Cable Assembly; G-28A Fuse.

-hp- 476A

Nominal Impedance: 50 ohms.

Maximum SWR: Less than 1.15, 20 to 500 MC.
Less than 1.25, 10 to 1,000 MC.

Maximum Power: 10 milliwatts.

RF Connector: Type N, UG23/U.

Output Connector: Type BNC, UG625/U.

Bolometer Element: Four 1/100-ampere Buss instrument fuses, specially selected and treated. (-hp- G-28B).

Accessories Available: AC-16F rf Cable Assembly; AC-16K Video Cable Assembly.

Data subject to change without notice.

Wide-Band Matching System for Microwave Power Measurements

The -hp- 475B Bolometer Mount (above) is convenient for making accurate microwave power measurements. It is a double-stub tuner capable of matching 50 ohm coaxial systems into 100 or 200 ohm bolometers and is continuously tunable, 1,000 to 4,000 MC. The instrument uses a Sperry 821 or Narda N821 barretter, a thermistor or a 1/100-ampere instrument fuse. Rf energy absorbed by the bolometer is measured by means of a bolometer bridge, or by using a self-balancing bridge such as -hp- 430B or 430C Microwave Power Meter (see page 91).

-hp- 476A UNIVERSAL BOLOMETER MOUNT

No Tuning, No Adjustment. 10 to 1,000 MC



Used with -hp- 430B/C Microwave Power Meter, this universal bolometer mount measures power from 10 to 1,000 MC and gives instantaneous, automatic power readings from 0.02 to 10 milliwatts. No tuning or adjustment is necessary. Higher powers may be measured by use of attenuators and directional couplers in conjunction with Model 476A. SWR is low, and reflected power is less than 0.1 db under most conditions.

hp 477A/487A THERMISTOR MOUNTS

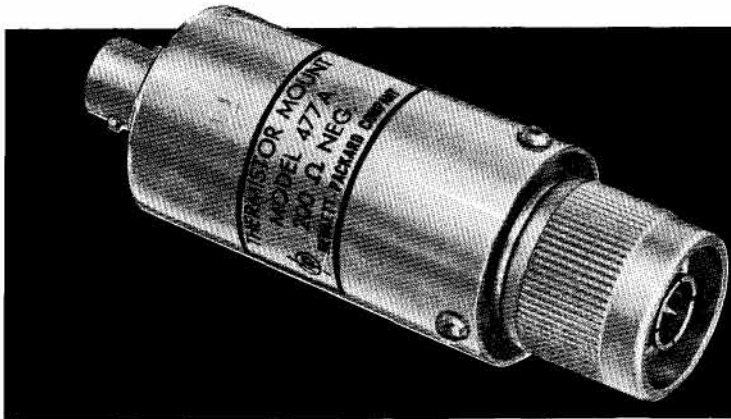

-hp- 477A Coaxial Mount

This thermistor mount provides full frequency coverage 10 MC to 10 KMC with SWR of less than 1.5. It requires no tuning, and employs long time-constant elements assuring measurement accuracy even for low duty cycle pulses. The instrument is not susceptible to burnout even at power levels as high as 1 watt.

-hp- 477A is designed for use with the -hp- 430C Microwave Power Meter (page 91) and can also be used with other bolometer bridges providing negative temperature coefficient operation at the 200 ohm level. Approximately 13 ma of bias is required.

Specifications

Frequency Range: 10 MC to 10 KMC.

SWR: Less than 1.5 (less than 1.3—50 MC to 5 KMC).

Power Range: 0.02 to 10 mw (with -hp- 430C Microwave Power Meter).

Connectors: Input—Type N Male; Output—Type BNC.

Element: 200 ohm, negative temperature coefficient.

Accessories Available: AC-16K Video Cable Assembly.

Data subject to change without notice.



-hp- 487A Waveguide Mount

Use of these new -hp- detector mounts simplifies setups, saves operator time and provides maximum accuracy in the measurement of microwave power from 4 to 12 KMC.

Each mount covers the full frequency range of its waveguide band, has an SWR of less than 1.5 at all frequencies, (except X-band which is 1.75), and requires no tedious tuning. Permanently installed Type 32A5 (Victory Eng. Co.) thermistors make the mounts ideal for measuring average power of low duty cycle pulses. The large overload factor of the thermistor plus careful design causing the majority of power to be reflected under overload conditions, makes burnout virtually impossible.

-hp- 487A mounts are designed for use with microwave power meters such as -hp- 430C (page 91). They are equipped with flat cover flanges and a BNC output connector.

Specifications

Model	Frequency Range (KMC)	Waveguide Size (in.)	Length (in.)
G487A	3.95 - 5.85	2 x 1	2½
J487A	5.3 - 8.20	1½ x ¾	2
H487A	7.05 - 10.00	1¼ x ¾	1¾
X487A	8.20 - 12.40	1 x ½	1½

SWR less than 1.5 full range (except X-band which is 1.75). Mounts employ permanently installed 200 ohm negative temperature coefficient thermistors.

Thermistor Time Constant: Approx. 1 sec when cooling on an open circuit.

Maximum Power Level: 3 mw.

Connector: Type BNC.

Accessories Available: AC-16K Cable Assembly.

hp 485 DETECTOR MOUNTS

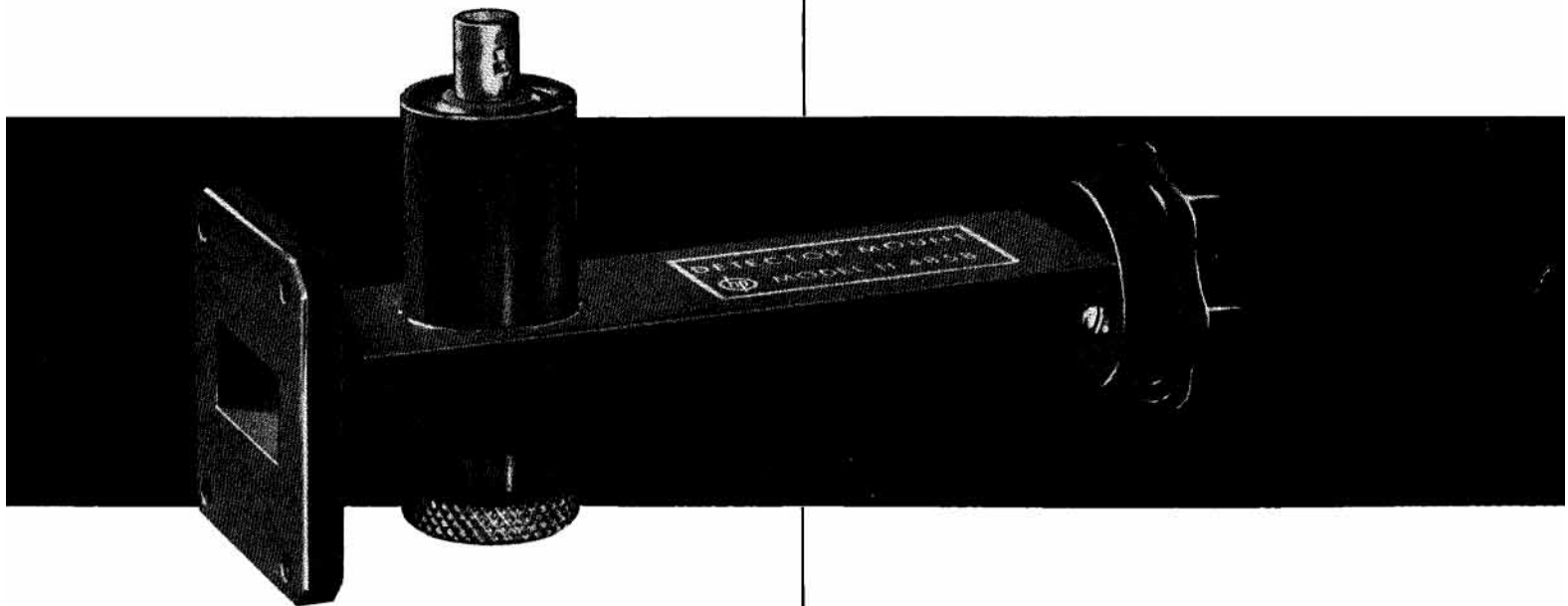

Specifications

Model	Maximum SWR	Frequency Range KMC	Waveguide (Size in.)	Length (in.)
S485A	1.35	2.60 - 3.95	3 x 1 1/2	4 5/8
G485B	1.25	3.95 - 5.85	2 x 1	10 5/8
J485B	1.25	5.85 - 8.20	1 1/2 x 3/4	6 1/4
"	1.35	5.50 - 5.85		
"	1.50	5.30 - 5.50		
H485B	1.25	7.05 - 10.00	1 1/4 x 5/8	5 7/8
X485B	1.25	8.20 - 12.40	1 x 1/2	5 7/8
P485C	1.25	12.40 - 18.00	.702 x .391	5 1/4

All mounts accept either crystal or barretter except -hp- S485A, which employs barretter only, and P485C, which employs permanently installed thermistor (supplied with P485C)

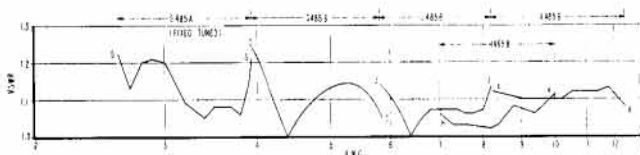

Figure 1. Typical SWR vs. Frequency, -hp- 485, when used with barretter.

Data subject to change without notice.

Simple Device for Measuring or Detecting rf Power

OFFERED in two basic models, these detector mounts are designed so that a single tuning control is sufficient to accurately match waveguide sections to a bolometer element for measuring power. For the detection of rf energy the bolometer element can be replaced by a crystal.

Model S485A (for the frequency band 2.6 to 3.95 KMC only) is designed for use with a Sperry 821 or Narda N821 barretter and requires no tuning. It has an SWR of less than 1.35 over entire waveguide band.

485B series, for higher waveguide frequencies, are tuned by a variable short which can be adjusted to an SWR of less than 1.25 over respective waveguide bands. For power measurements this results in a reflection loss of less than 0.1 db. 485B models accommodate either a 1N21 or 1N23 silicon crystal or a Sperry 821 or Narda N821 barretter.

In all models detected output appears at a BNC jack mating with a UG88/U plug. Detector elements can be quickly interchanged. For measuring maximum power from a mis-matched source, these detectors may be preceded by a slide screw tuner such as -hp- 870A. The detectors are also ideal for use with -hp- 430C Microwave Power Meters, or -hp- 415A/B Standing Wave Indicators.

IMPEDANCE MEASUREMENTS



OF ALL the possible measurements to be made in design and production, probably the most important one is impedance measurement. With distributed parameters an impedance varies with the position of measurement. Hence all impedance measurements must be referred to some reference plane. Since impedance is a measure of reflected energy caused by the load, information concerning a load can often be obtained by determining the magnitude of the reflection coefficient.

The value of the reflection coefficient can be determined by using a slotted section of a transmission line and measuring the standing wave ratio, (ratio of maximum to minimum voltage in the system feeding the load). It also can be measured directly with a reflectometer by sampling the incident and reflected waves and obtaining their ratio which is equal to the reflection coefficient. The reflectometer method will be explained following the discussion of the slotted line.

Slotted Line Measurements

A typical setup for making slotted

line measurements is shown in Figure 1. The transmission system contains the incident wave and a reflected wave which is proportional to the mismatch of the load. These two waves will alternately cancel and add, setting up a standing wave pattern along the line. By inserting a probe into the slotted section and sliding it along the line the resultant voltage pattern can be measured. The usual practice is to amplitude modulate the signal source and to use a crystal or bolometer to detect the probe output. The detected output of the probe is connected to a high sensitivity, tuned voltmeter, such as -hp-415B Standing Wave Indicator. Using this procedure, the SWR and the position of maxima and minima of the load can be determined. The load is then replaced by a short circuit and the shift of the minimum is recorded. A proper transformation of this information can be entered on a Smith Chart from which the point of measurement can be referred back to the load or point of interest. In this way, one can quickly determine the value of the impedance and the reflection coefficient in magnitude and phase.

Slotted Line Techniques

In measuring with this setup there are several places where errors may occur. A proper operating technique will eliminate or minimize these errors. Errors may arise from the following causes: Probe loading, generator match, detector characteristics, harmonics, FM, and other spurious generator signals.

Harmonics and spurious signals can be minimized by use of low pass filters such as Hewlett-Packard 360 series. Proper modulation techniques are explained in the signal generator section of this catalog (pages 63-65). Of special importance is the fact that modulation should not be attempted by very short pulses or poor quality square waves. When modulating klystrons in such a manner the resulting FM tends to obscure the nulls of the standing waves. To avoid FM, modulation of klystron signal sources should be by square wave.

Since the ratios of different voltage levels are being measured with slotted lines, it is essential that the detector follow the same law for all levels. If barretters are operated at levels less than 200 microwatts and crystals at power levels of less than 20 microwatts, the characteristics are essentially square law. It is upon this assumption that the -hp- 415B meter scale is calibrated. This condition will be adequately met in the setup shown in Figure 1 (for standing wave ratios of 10 to 1 or less), if the probe coupling is reduced to a point where the minimum is 5 to 10 db above the system noise level.

The sampling probe will extract some power from the line to supply the indicating devices and in addition will set up reflections in the line from the probe itself. Both errors become greater as the probe insertion is increased. It is therefore important in slotted line measurement to keep the probe penetration at a minimum.

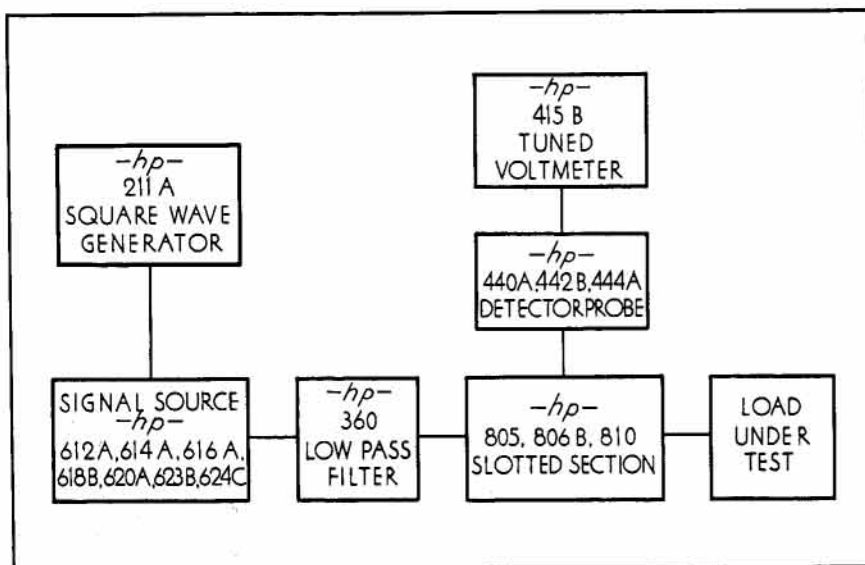

Figure 1: Typical set-up for impedance measurements.

The power extraction by the probe can be explained by considering the probe as admittance shunting the line. This admittance is kept small by coupling as loosely as possible (small penetrations) and by using a high sensitivity detector in conjunction with a source output of one milliwatt or more. If the coupling between the probe and the line is not small, shunt admittance introduced by the probe will cause the measured SWR to be lower than the true SWR (as shown in Figure 2) and will shift both the maximum and the minimum from their natural position.

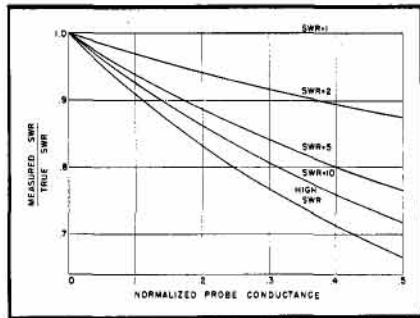

Figure 2: Effect of probe penetration on measured SWR.

An exception to this minimum penetration rule occurs when it is desired to examine in detail the minimum point on the standing wave ratio pattern. For this work a greater probe penetration can be tolerated because the minimum corresponds to the lowest impedance point on the line.

In addition to extracting power from the line, the penetration of the sampling probe into the slotted section gives rise to reflections from the probe itself. These reflections travel back towards the generator. If the generator is mismatched, these reflections are re-reflected. When the probe is moved under these conditions, the phase of the reflection is changed and errors result. However, reflections from the generator are a second-order effect, important only when measuring low standing wave ratios (2 to 1 or less). In this case, a moderately good match between the generator and load is desirable. In general, the match of an *-hp-* signal generator is sufficient for this purpose, providing the cables and connectors do not introduce spurious reflection.

However, when klystrons are used directly to feed a wave-guide network, the match is poor. Therefore, the klystron should always be followed by a pad.

Various methods of measuring SWR's have specific advantages for different SWR ranges. Straight-for-

To measure SWR's greater than 10 to 1 within 1% accuracy, the twice-minimum-power method is recommended. Here, it is only necessary to establish the electrical distance between the points that are twice the amplitude of the minimum. The SWR can be obtained by substituting this dis-

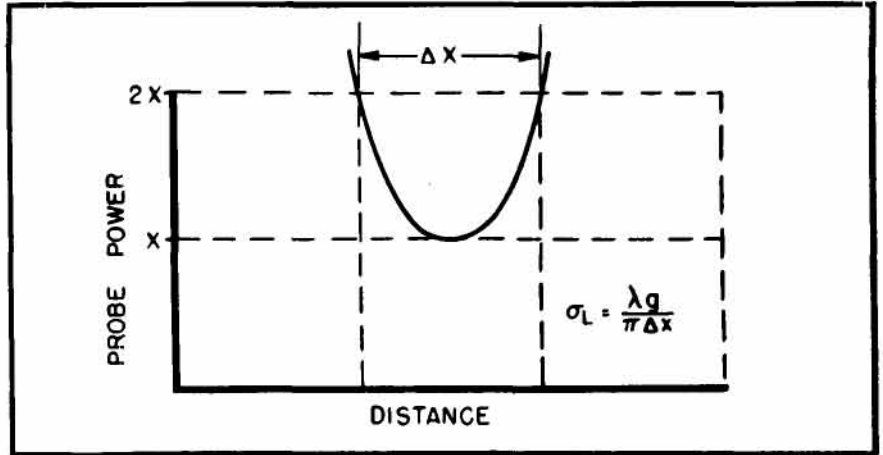

Figure 3: Twice minimum power method for measuring SWR.

ward measurement of SWR by conventional methods is generally preferred when measuring SWR's in the range of 10 to 1 or less. But when the SWR is high in order to obtain readings at the minimum. This may result in deformation of pattern when the maximum is measured. There is also a possibility of error due to a change in detector characteristics because of rf level changes.

tance into the following expression as shown in Figure 3:

$$\sigma_L = \frac{\lambda_g}{\pi \Delta x}$$

σ_L = Voltage Standing Wave Ratio of Load

λ_g = Guide wavelength

Δx = Distance between "twice-minimum-power" points

The value referred to in this method is the twice-power value. Therefore,

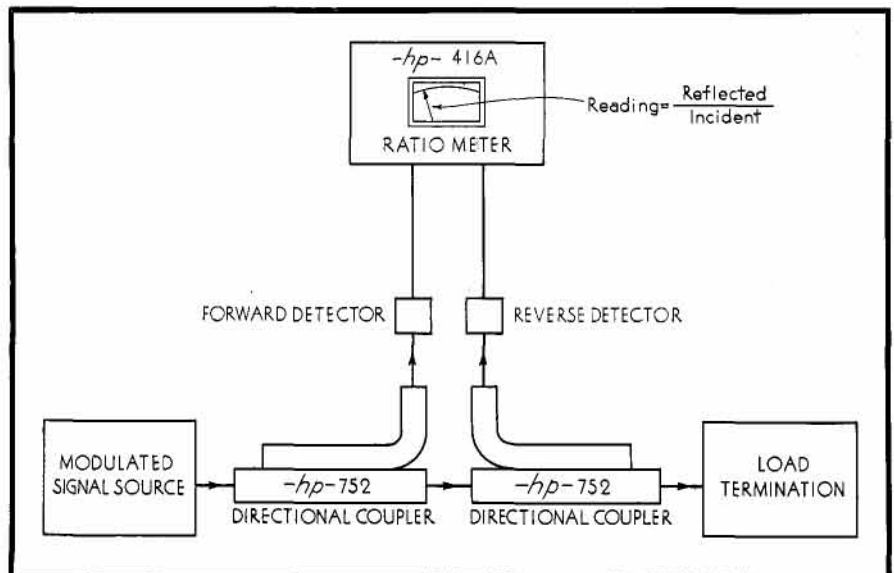

Figure 4: Typical Reflectometer set-up.

if the linear voltage indicator is used with a square-law detector, the voltage indication of the twice-power point will be twice that of the minimum. If a standing wave indicator (calibrated for use on a square-law detector such as the -hp- 415B or a linear receiver) is used, the ratio of the two readings will be 1.4 to 1 voltage-wise or 3 db power-wise.

Reflectometer Measurements

An additional method of making impedance measurements conveniently is by use of a reflectometer. The reflectometer will indicate magnitude of the impedance but will not provide phase angle information as does the slotted line. The reflectometer is most useful for fast, swept frequency, production measurements.

A typical reflectometer setup is shown in Figure 4. This arrangement determines the magnitude of the reflection coefficient by use of directional couplers which sample the input wave and the reflected wave. The couplers feed to detectors and then to a ratio meter (such as -hp- 416A, page 98) where a direct comparison is made. The resultant ratio of the two sampled powers is read directly on the ratio meter. For best results in reflectometer operation the input power should be kept to a low level by means of input attenuators so that the power at the forward detector is in the order of -20 dbm. At the reverse detector it should be in the order of -10 dbm at the calibration point. This will more nearly insure square-law operation of the crystal.

-hp- Reflectometers are available to measure the magnitude of reflection coefficients rapidly and with good accuracy in the popular waveguide frequencies. This method is most practical for measuring reflection coefficients up to approximately 0.5 (SWR of 3.0). When the reflectometer is used with swept-frequencies and is calibrated with a short, accuracies of within approximately ± 0.02 can be obtained for reflection coefficients of 0.1 (SWR of 1.22). For reflection coefficients of 0.4 (SWR of 2.3) accuracies of within approximately ± 0.04 (SWR of 1.08) can be obtained. The

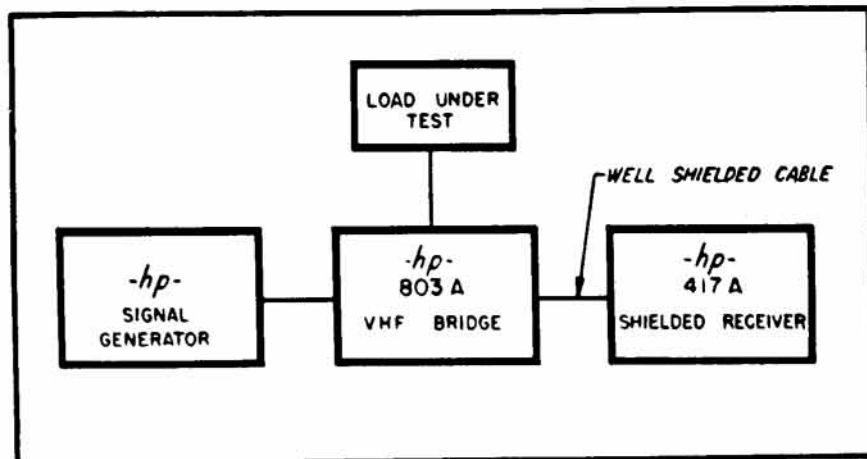

Figure 5: Impedance measurements for frequencies below 500 MC.

potential accuracy of the reflectometer is greatest at low SWR's when using a fixed frequency, a sliding short for calibration, a slide screw tuner, and a moving load. Under ideal conditions errors of less than $\pm .005$ in reflection coefficient equal to residual SWR of 1.01 are attainable.

Impedance Measurements With vhf Bridge

Below 500 MC, slotted sections become exceedingly long; and other techniques for impedance measurements are more desirable. For these frequencies, -hp- Model 803A vhf Bridge is ideal. (See Figure 5.)

The vhf Bridge provides a convenient means of measuring impedances, reading directly both magnitude and phase angle. The Bridge is operated simply by tuning two controls until a sharp null is obtained. At the null, one dial reads unknown impedance in ohms and the other dial shows phase angle.

Because of the null nature of the measurement, the voltages measured are very small. Therefore, to avoid any effects from extraneous voltages, lines connected to the bridge should be adequately shielded. The signal source supplying this bridge should be capable of delivering several milliwatts of power for a well defined sharp null to be observed. The detecting equipment should have high sensitivity, as does the -hp- 417A vhf Detector which is designed primarily to be used with Model 803A Bridge.

The bridge is basically an unbalanced device; and in many cases it is desirable to measure balanced systems. This can be accomplished by the use of a balun, a simple form of which is shown in Figure 6.

This structure is equivalent to a 4 to 1 impedance transformer. Hence, impedances measured at the input of the balun should be multiplied by 4 to obtain the actual impedance.

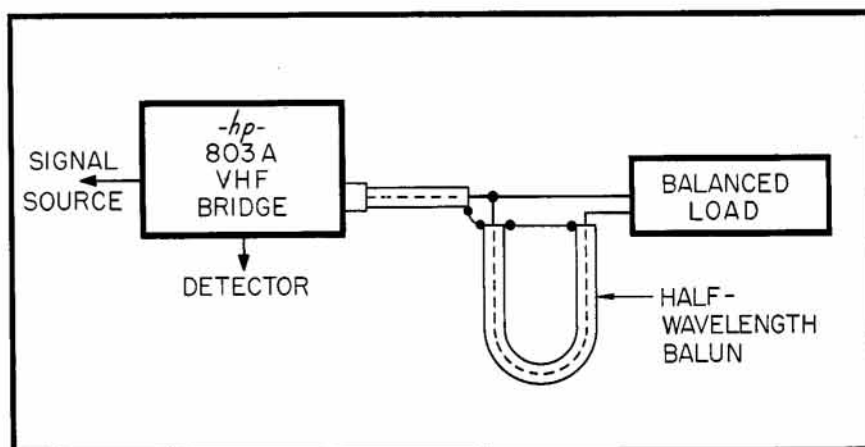

Figure 6: Measurement set-up using balun with balanced load.

hp 416A RATIO METER



Advantages:

- Makes waveguide reflection coefficient measurements practical
- Allows continuous swept-frequency oscilloscope presentation
- Eliminates amplitude-variation error
- Operates accurately over 20/1 incident power level range
- Simplifies reflectometer setups for faster production checks, wide band system alignment and laboratory investigation

Use For:

- Fast reflection coefficient measurements over broad frequency range
- SWR measurement independent of rf power level

New Ease, Accuracy for Reflection Coefficient Measurements

REFLECTION coefficient measurements with a reflectometer setup are recognized as an ideal method of evaluating waveguide system performance. The reflectometer setup can save engineering time by eliminating tedious SWR measurements with slotted lines, and when driven by a swept oscillator (such as -hp- 670 shown on page 76), such setups make possible direct and continuous oscilloscope presentation of reflection coefficient over a wide frequency range.

The new -hp- 416A Ratio Meter eliminates the two major drawbacks heretofore present in the reflectometer setup by eliminating adjustments to correct for source amplitude variations and eliminating necessity for measuring separately the forward and reverse power.

-hp- 416A automatically combines forward and reverse signals and displays their ratio directly, irrespective of amplitude variations.

The instrument also is an excellent standing wave indicator for conventional slotted line measurements, and in this application again eliminates the inconvenience of adjustments necessitated by power source amplitude variations.

Reflectometer Setup

Arrangement of a typical reflectometer setup with *-hp-* 416A Ratio Meter is shown in Figure 1. This setup provides continuous and direct oscilloscope presentation of the reflection coefficient of an unknown load at varying frequencies. A swept oscillator supplies power through directional couplers mounted back-to-back. One coupler samples forward power, the other reverse or reflected power. Both couplers are terminated in waveguide detector mounts such as *-hp-* 421A which demodulate system power and provide 1,000 cps signals to the ratio meter. The oscilloscope presents frequency on its horizontal axis vs. reflection coefficient on the vertical axis. Thus a continuous visual study can be made of reflection coefficient at any frequency within the system's range.

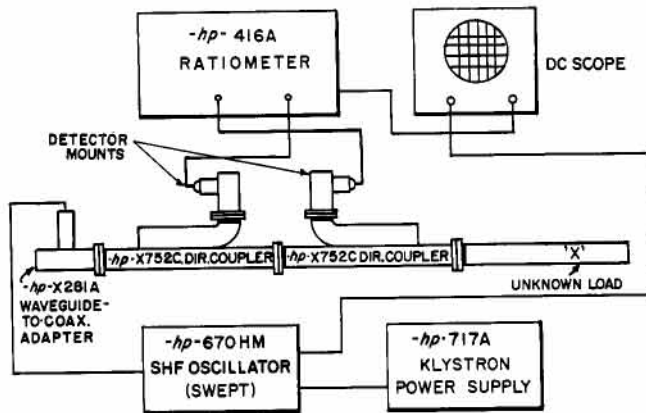

Figure 1. Typical Reflectometer Setup. Note use of two directional couplers back-to-back, with individual detectors, for simultaneous evaluation of incident and reflected powers.

Simple Operation

The *-hp-* 416A operates in an exceptionally straightforward manner. An rf power monitor on the panel indicates the proper power level and modulating frequency. The system is calibrated by employing a short in place of the load to establish the point of 100% reflection. Also, standard reflections such as *-hp-* 916A (see page 114) may be employed to establish calibration.

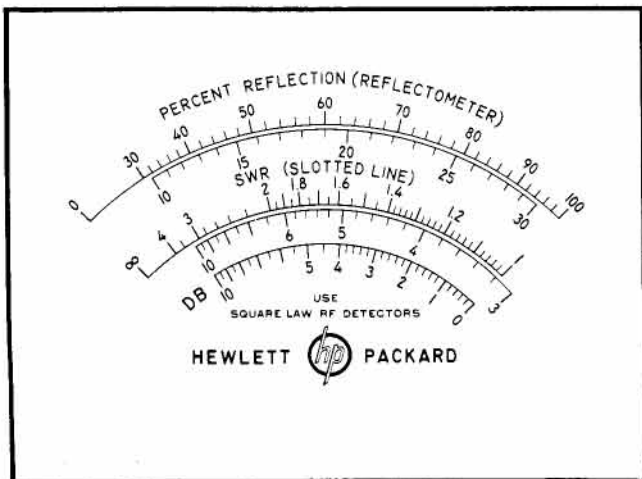

Figure 2. Meter scale, *-hp-* 416A Ratio Meter. Note that meter has separate scales for percentage reflection, SWR, and db.

When the ratio meter is used as an SWR indicator, a similarly simple adjustment is all that is required to establish unity SWR at a voltage maximum point on the slotted line.

Extreme Accuracy

Model 416A is capable of the highest accuracy—exceeding that of the best slotted line sections—when measurements are made at a single frequency. Using a slide-screw tuner such as *-hp-* 870A (see page 111) to compensate for the small directivity deficiency of *-hp-* 752 Directional Couplers, accuracy of better than ± 0.005 can be expected. This is equivalent to a residual SWR of approximately 1.01. For swept frequency operation, accuracies of ± 0.015 can be expected with loads having small SWR. Even with loads having high SWR, accuracies of 0.05 can be expected.

Specifications

Accuracy: $\pm 3\%$ full-scale for 20 to 1 range of incident or reference rf power.

Calibration: Square-law.

Frequency: 1,000 cps ± 40 cps.

Input Voltage: Incident or Reference Channel: 3 mv to 100 mv rms.

Reflected or Probe Channel: 0.3 μ v to 100 mv rms. (Square or sine-wave.)

Input Impedance: Approximately 75 K ohms, both channels.

"Excess Coupler Loss": Includes provision for increasing sensitivity of Incident Channel by 10 db for reflectometer setups employing couplers with different coefficients.

Output: Connectors for oscilloscope and high impedance recorder.

Adjustments: "Set to Full Scale" control for initial calibration with 100% reflection, or at SWR peak.

Internal Check: "Eye" tube continuously monitors input amplitude (and frequency indirectly) to assure proper operating range for instrument and crystal detectors.

Connectors: Type BNC.

Power: 115/230 v $\pm 10\%$, 50/60 cps, 90 watts.

Dimensions: Cabinet Mount: 20 $\frac{3}{4}$ " wide, 12 $\frac{1}{2}$ " high, 14 $\frac{3}{4}$ " deep. Rack Mount: 19" wide, 10 $\frac{1}{2}$ " high, 14 $\frac{1}{2}$ " deep.

Weight: Net 36 lbs. Shipping 78 lbs. (cabinet mount).

Accessories Furnished: 2 AC-16K Video Cable Assemblies.

Accessories Available: AC-16K Video Cable Assembly.

Data subject to change without notice.

hp 803A VHF BRIDGE



Advantages:

- Direct reading,
 - 2 to 2,000 ohm impedances
 - 90° to +90° phase angle
- Wide range, 50 to 500 megacycles
- Simple, easy operation
- Faster than slotted lines
- Compact size
- Standard Type N connector

Uses:

- Determines characteristics of:
 - Antennas
 - Transmission Lines
 - Rf chokes
 - Resistors
 - Condensers
- Measures:
 - Connector impedances
 - Standing wave ratios
 - % reflected power
 - Vhf system flatness

Reads Any Impedance Directly Between 50 and 500 MC

MODEL 803A vhf Bridge is the first commercial equipment built to provide direct impedance measurements in the vhf range. It measures impedance by sampling the electric and magnetic fields in a transmission line. Two attenuator systems are controlled simultaneously. One responds to the electric field in the transmission line, and the other responds only to the magnetic field in the transmission line. The combination is adjusted for equal output from each attenuator. These two signals are applied to opposite ends of a transmission line. Phase is determined by finding their point of cancellation. (See diagram.) This method effectively overcomes the narrow frequency limitations of conventional bridges, and permits -hp- Model 803A to make readings at frequencies up to 1,000 MC and down to 5 MC.

Simple to Operate, Direct Reading

In operation, the instrument is similar to a standard bridge, much simpler to use and more compact than a slotted line. Two controls are simultaneously tuned until a sharp null is obtained. At the null, one dial reads unknown impedance direct in ohms, and the other dial shows phase angle.

Impedances between 2 and 2,000 ohms are read directly, and higher or lower values may be readily determined by using a transmission line of known length as an impedance transformer. Phase angles up to $\pm 90^\circ$ can be measured at frequencies as low as 52 MC. Calibration of phase angle is direct in degrees at 100 MC, and angles at other frequencies can be readily determined by multiplying angle read by frequency in MC and dividing by 100.

Broad Usefulness

Virtually all measurements which can be made with a slotted line can be made more easily and swiftly with the compact Model 803A vhf Bridge. The instrument is extremely useful for determining rf resistance—even at frequencies as low as 5 MC or high as 1,000 MC. It also offers fast, accurate determination of antenna and transmission line characteristics and impedances, capacity, inductance, etc. Its broad usefulness makes this equipment a real time saver to engineers working in the vhf band.

Specifications

-hp- 803A

Measurement Range: Impedance magnitude, 2 to 2,000 ohms. Higher and lower values may be measured by using a known length of transmission line as an impedance transformer.

Phase angle from -90° to $+90^\circ$ at 52 MC and above.

Calibration: Impedance: Directly in ohms.

Phase angle: Directly in degrees at 100 MC. May be readily computed at other frequencies.

Phase angle (actual) = Phase Angle (read) \times Frequency, MC/100.

Accuracy: (Over range 52 to 500 MC). Impedance magnitude, better than $\pm \left(5 + \frac{\text{Frequency, MC}}{500} \right) \%$

Phase angle better than $\pm \left(3 + \frac{\text{Frequency, MC}}{500} \right)$ degrees.

Charts are provided with each instrument so that impedance readings may be corrected to better than $\pm 2\%$ and phase angle to better than $\pm 1.2^\circ$ over the entire frequency range.

Frequency Range: Maximum accuracy 52 to 500 MC. Useful down to 5 MC and up to 1,000 MC. Maximum measurable phase angle at 5 MC is -9° to $+9^\circ$.

External rf Generator: Requires an AM signal source of at least 1 mw. High signal level is desirable. (-hp- Model 608C vhf Signal Generator is ideal for this purpose.)

RF Detector: Requires a well-shielded vhf receiver of good sensitivity. (-hp- Model 417A, vhf Detector, is designed for this use.)

Dimensions: Cabinet Mount: 14" wide, 15" high, $8\frac{3}{4}$ " deep.

Weight: Net 25 lbs. Shipping 40 lbs.

Accessories Furnished: 1 803A-16D Cable Assembly; 1 803A-16E Cable Assembly; 1 803A-76G Shorting Plug.

-hp- 417A VHF DETECTOR



This -hp- instrument is a super-regenerative (AM) receiver covering all frequencies between 10 and 500 MC in 5 bands. It is designed for use with the -hp- 803A Bridge. It offers a high sensitivity of 5 microvolts over the entire frequency band. It is designed for fast, simple operation, and has a single, convenient frequency control directly calibrated in megacycles.

The instrument is thoroughly shielded and is suitable for general laboratory use, including the determination of approximate frequency, noise, interference, etc. It is light weight for portability, sturdily built, and compact to occupy a minimum of bench space.

Specifications

-hp- 417A

Frequency Range: 10 to 500 MC, continuous coverage, 5 bands. Directly calibrated in MC.

Sensitivity: Approximately 5 microvolts over entire frequency range.

Power: 115 v \pm 10 v, 50/60 cps, 30 watts.

Dimensions: Cabinet Mount: $9\frac{1}{4}$ " wide, $12\frac{3}{4}$ " high, 9" deep.

Weight: Net 17 lbs. Shipping 30 lbs.

Accessories Available: AC-16F rf Cable Assembly; AC-16Q rf Cable Assembly; 803A-16E Input Cable Assembly.

Data subject to change without notice.

hp 805 SLOTTED LINE

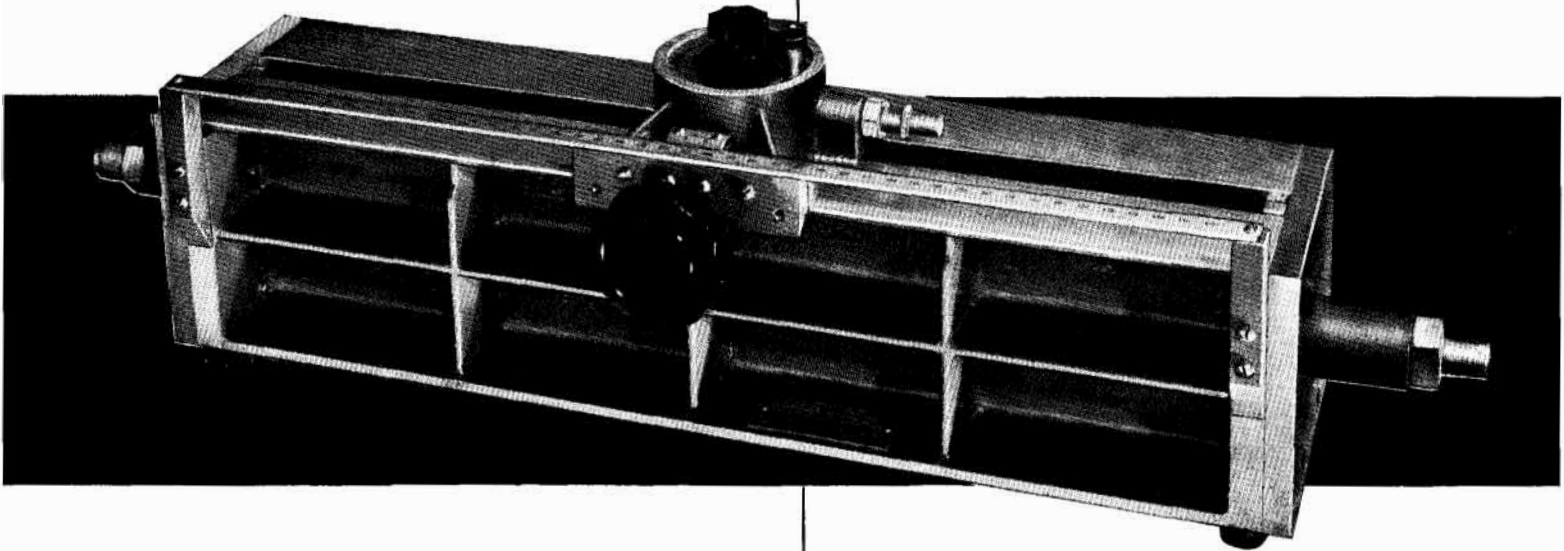

Specifications

-hp- 805A

Frequency Range: 500 MC to 4,000 MC (minimum frequency determined by usable length of 14½ inches).

Characteristic Impedance: 50 ohms. (For use with such flexible coaxial cables as RG: 8/U, 9/U, 10/U, 14/U, 17/U, 18/U, 21/U.

Connections: TYPE N. (One male; one female.) Special fittings designed to mate with TYPE N connectors, provide a minimum SWR. Connectors compensated so that either end may be connected to the load.

Residual SWR: 1.04.

Calibration: Metric, calibrated in cm and mm. Vernier permits reading to 0.1 mm.

Detector Probe: Tunable probe provided for entire frequency range. Detector element may be 1N21B crystal (supplied with instrument), Sperry 821 barretter, Narda N821 barretter, or selected 1/100 amp. instrument fuse.

Dimensions: Carrying case 29" wide, 9¾" high, 8¾" deep.

Weight: Net 33 lbs. Shipping 75 lbs.

Accessories Furnished: 1 Steel and dural carrying case; 1 803A-76G shorting plug; 1 8A-76A shorting jack; 1 8A-76E crystal adapter; 1 1N21B crystal detector.

Accessories Available: AC-16F Cable Assembly; 475B-34V Barretter Assembly.

-hp- 805B

Characteristic Impedance: 46.3 ohms. For use with RG 44/U stub supported coaxial cable. 7/8" outside diameter.

Connections: (One male, one female UG 45/U and UG 46/U.)

Residual SWR: 1.02.

(Other specifications same as -hp- 805A)

Data subject to change without notice.

New "Parallel-Plane" Design Gives Utmost Electrical Stability

THE -hp- 805 Slotted Line incorporates a radically different structural design with precision manufacture, resulting in an instrument of unvarying accuracy for the measurement of microwave circuits.

Greater Inherent Accuracy

This instrument employs two parallel planes and a rigid central conductor in place of the conventional coaxial arrangement. This configuration has several important advantages over the standard slotted section.

For example, it permits the parallel planes to be made mechanically rigid; thus insuring greater accuracy and providing a rigid probe carriage. The central conductor is proportionately larger and more rigid, with less tendency to bow. Depth of probe penetration is inherently less critical, and therefore carriage inaccuracies are minimized. Leakage is also low because the effective slot opening is small. This new design permits SWR of the basic section to be held to less than 1.02.

The probe circuit is tunable over the instrument's entire frequency range, 500 - 4,000 megacycles. Depth of probe penetration can be quickly and easily adjusted.

Two versions of the -hp- 805 are offered, the 805A being provided with type N connectors and the 805B with connectors suitable for mating to RG44/U stub supported coaxial cable.

hp 415B STANDING WAVE INDICATOR



New Meter Reads Direct in SWR and in db

New -hp- 415B is designed for use with -hp- slotted lines and detector mounts for the measurement of standing wave ratio. It can also be used as a null detector for bridge measurements. Consisting of a high gain amplifier with very low noise level, the instrument operates at a fixed audio frequency and presents amplifier output on a square law calibrated VTVM reading direct in SWR or db. Features include a 200,000 ohm input circuit for bridge or null measurements, a -5 db attenuator to allow all measurements to be made in the more readable upper portion of the meter scale, an expanded SWR scale for accurate measurements of very flat systems, and a recorder output terminal for making permanent SWR records. A simple gain control adjusts the instrument to a convenient level and is equipped with a vernier knob for precise zero setting.

Input Arrangements

Three input arrangements are provided. A switch selects (1) a 200 ohm termination with bias of 4.3 or 8.4 ma for bolometers, (2) an unbiased 200 ohm termination for crystals, (3) a 200,000 ohm load for null measurements. A jack and monitor cable are provided for connecting an external milliammeter to measure bolometer current.

The instrument is normally supplied for operation at 1,000 cps. However, on special order it is available equipped for operation at any frequency from 315 to 3,000 cps. The frequency determining network is "plug-in." Units for converting the 415B to operation at any frequency in the above range can be obtained at nominal charge and installed in the field.

Specifications

- Frequency:** 1,000 cps $\pm 2\%$.
- Sensitivity:** 0.1 μ v at a 200 ohm level for full scale deflection.
- Noise Level:** Less than 0.03 μ f ref. to input operated from a 200 ohm resistor.
- Amplifier Q :** 25 ± 5 .
- Calibration:** Square law. Meter reads SWR, db.
- Range:** 70 db. Input attenuator provides 60 db in 10 db steps. Accuracy ± 0.1 db per 10 db step.
- Scale Selector:** "Normal," "Expand," and " -5 db."
- Meter Scales:** SWR: 1-4; SWR: 3-10; Expanded SWR: 1-1.3; db: 0-10; Expanded db: 0-2.
- Gain Control:** Adjusts to convenient reference level. Range approx. 30 db.
- Input:** "Bollo" (200 ohms). Bias provided for 8.4 ma bolometer or 1/100 amp. fuse; or 4.3 ma low current bolometer.
- "Crystal," 200 ohms for crystal rectifier.
- "200,000 ohms." High impedance for crystal rectifier as null detector.
- Output:** Jack for recording milliammeter having 1 ma full scale deflection, internal resistance of approx. 1,500 ohms.
- Input Connector:** BNC.
- Power:** 115/230 v $\pm 10\%$, 50/60 cps, 60 watts.
- Dimensions:** Cabinet Mount: 7 $\frac{1}{4}$ " wide, 11 $\frac{1}{4}$ " high, 14" deep. Rack Mount: 19" wide, 7" high, 11" deep.
- Weight:** Net 20 lbs. Shipping 35 lbs. (cabinet mount).
- Accessories Furnished:** 1 AC-16D Cable Assembly; 1 41A-16E Cable Assembly.
- Accessories Available:** 415B-42B Plug In Filter (315-3,000 cps), AC-16K Video Cable Assembly.

Data subject to change without notice.

hp 809B UNIVERSAL PROBE CARRIAGE

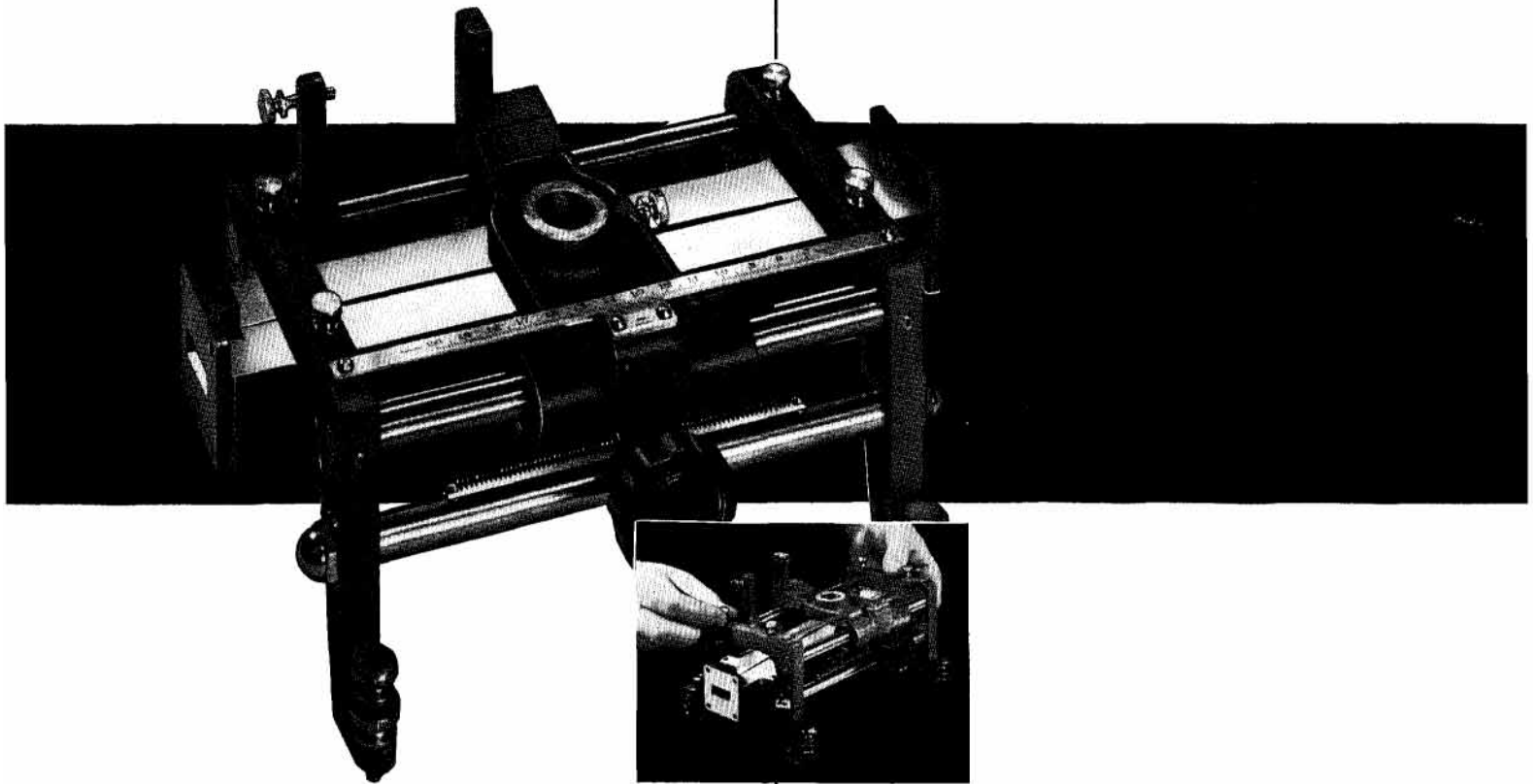

Advantages:

- Universal carriage mounts 6 different slotted sections
- Broad usefulness, 3,000 to 18,000 MC.
- Carriage operates with *-hp-* waveguide or coaxial slotted sections.
- Precision accuracy, high stability
- Sections interchange in 30 seconds
- Mounts dial gauge for higher accuracy
- Simple operation, compact, low cost

Use It To Measure:

- Characteristics of rf waveguide systems or coaxial transmission lines
- Standing wave magnitude and phase
- Impedance
- System flatness, connector reflection
- Degree of antenna match
- Percent of transmitted or reflected power

Low-Cost, Precision Tools for Microwave Readings

MODEL 809B Universal Probe Carriage is a precision-built mechanical assembly designed to operate with five *-hp-* 810B Waveguide Slotted Sections covering frequency ranges from 3.95 KMC to 18.0 KMC and with *-hp-* 806B Coaxial Slotted Section, 3.0 to 12.0 KMC.

Model 809B provides, in one compact instrument, equipment that greatly simplifies waveguide measurements over a number of frequency bands and eliminates the cost of a probe carriage for each waveguide band. It saves appreciably on engineering time since waveguide sections can be interchanged in 30 seconds or less. It is lightweight and easily portable and is designed for use with either *-hp-* 444A Untuned Probe or *-hp-* 440A Detector and *-hp-* 442B Broadband Probe in combination. (See page 106.) The unit has a centimeter scale with a vernier reading to 0.1 mm. Provision is also made for mounting a dial gauge where more accurate readings are required.

The instrument is simple in mechanical design and is carefully manufactured to assure trouble-free operation. The probe carriage moves on ground stainless steel rods, and its 3-point suspension system includes two linear-

motion ball bearings with dust seals and permanent lubrication. A conventional ball bearing forms the third point of suspension. Accuracy is superior or equal to the most expensive custom-made slotted lines.

-hp- 810 Waveguide Slotted Sections. Waveguide slotted sections are fundamental tools for the measurement of magnitude and phase of standing waves in a waveguide system. Such data may be transformed readily into impedance of terminal load of the system or components. Slotted sections may also be used to measure reflection, percent of transmitted power, degree of antenna match and other waveguide characteristics.

-hp- 810B Waveguide Slotted Sections comprise an accurately-machined section of waveguide in which a small longitudinal slot is cut. They are designed and finished to fit -hp- 809B Carriage in a precisely indexed position. A traveling probe mounted on the 809B Carriage samples the waveguide's electric fields along the slot and permits precise plotting of variations along the entire length of

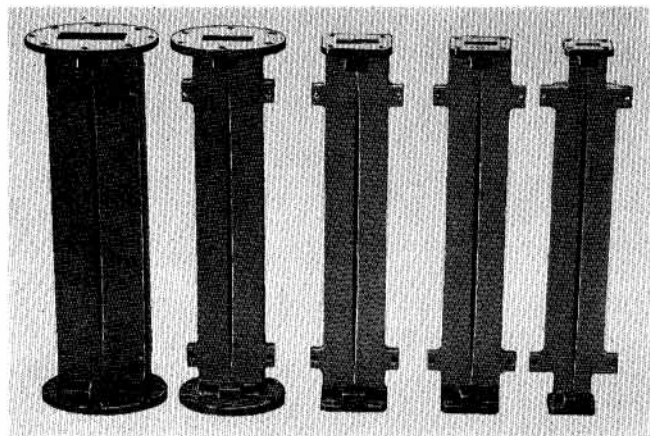

-hp- 810B Waveguide Slotted Sections

probe travel. The slotted sections are carefully machined from normalized aluminum castings to insure a uniform cross-section.

Ends of the slots are tapered to reduce slot reflection to less than 1.01 SWR. A high order of accuracy and stability is maintained. -hp- 810B sections are available for five common waveguide frequency-sizes. (See specifications.)

-hp- 806B Coaxial Slotted Section. This instrument provides continuous coverage from 3.0 to 12.0 KMC and is designed for use with -hp- 809B Universal Probe Carriage. Impedance is 50 ohms to match flexible coaxial cables. This broadband coaxial slotted section has special fittings mating with Type N connectors to assure a minimum SWR.

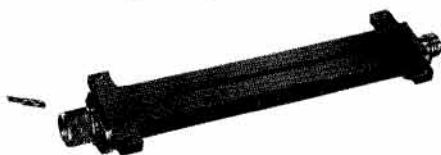

-hp- S810A Waveguide Slotted Section is a conventional type of slotted waveguide complete with probe carriage mounted directly on the section. Model S810A is available in the 3" x 1 1/2" (2.6 to 3.95 KMC) frequency only. The instrument uses -hp- Broadband Probes and Detector Mounts (see page 106.)

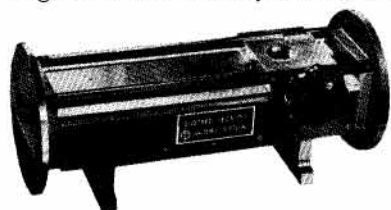

Specifications

-hp- 809B Universal Probe Carriage

Carriage: Mounts all -hp- 810B Waveguide Slotted Sections and -hp- 806B Coaxial Slotted Section.

Probe Required: -hp- 442B Broadband Probe in combination with -hp- 440A Detector or -hp- 444A Untuned Probe. (See page 106.)

Probe Travel: 10 centimeters.

Calibration: Metric. Vernier permits readings to 0.1 mm. Provision for dial gauge installation.

Leveling Screws: Knurled thumb screws provided on all 4 carriage legs.

Accuracy: When used with waveguide sections, SWR of 1.02 can be easily read. Slope error of slotted sections may be eliminated by adjustment.

Size: 8" long, 6 1/4" wide; height 5".

-hp- S810A Waveguide Slotted Section

Conventional waveguide slotted section with probe carriage mounted directly on waveguide. Will accept -hp- 442B or 444A Probes.

Frequency Range: 2.6 to 3.95 KMC.

Waveguide Size: 3" x 1 1/2".

Length: 12 3/4".

-hp- 806B Coaxial Slotted Section

Carriage: Fits -hp- 809B Universal Probe Carriage.

Frequency Range: 3.0 to 12.0 KMC.

Connections: Type N, one male, one female. Special fittings, provide minimum SWR. Either end may be connected to load. Includes shorting connectors, male and female, for phase measurements.

Residual SWR: Less than 1.04, 3.0 to 8.0 KMC.

Approx. 1.06, 8.0 to 10.0 KMC.

Approx. 1.1, 10.0 to 12.0 KMC.

Pick-up Error: Probe pick-up variation along line is less than 0.1 db except at extreme ends where it is less than 0.2 db.

Length: 10".

-hp- 810B Waveguide Slotted Sections

Model	Frequency Range KMC	Waveguide Size (in.)	Overall Length (in.)
G810B	3.95 - 5.85	2 x 1	10 1/4
J810B	5.85 - 8.20	1 1/2 x 3/4	10 1/4
H810B	7.05 - 10.00	1 1/4 x 5/8	10 1/4
X810B	8.20 - 12.40	1 x 1/2	10 1/4
P810B	12.40 - 18.00	.702 x .391	10 1/4

Discontinuity due to slot results in SWR of less than 1.01.

Data subject to change without notice.



DETECTOR MOUNTS, PROBES

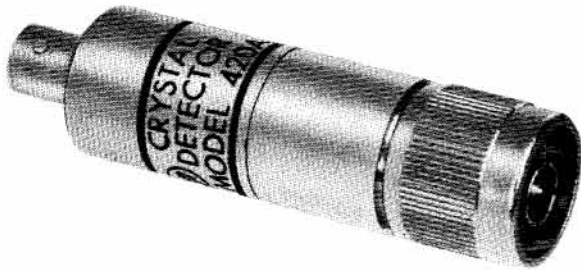

-hp- 420A Crystal Detector

This instrument, operating from 10 MC to 12.5 KMC, couples a Type N coaxial line to a modified 1N76 silicon crystal for detection of rf signals. Sensitivity is approximately 0.1 v/mw, and frequency response is ± 4 db full range. Maximum SWR is 3, output polarity is negative. Uses UG-21B/U Type N input and BNC output connector. Dia. $\frac{3}{4}$ ", length 3", weight 1 lb.

-hp- X421A Crystal Detector

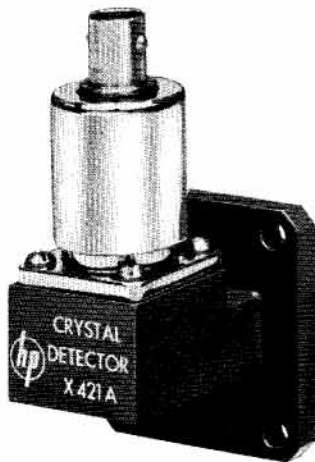

An accurate, square-law detector specifically designed for reflectometer measurements. Measures reflection coefficients as low as 0.01. Frequency coverage is 8.2 to 12.4 KMC, sensitivity is approximately 1 mv/0.01 mw, overall SWR is 1.5, frequency response is ± 2 db. For a matched pair of X421A's the frequency response is ± 1 db. The square-law characteristic is within ± 1 db over 40 db range for maximum input power of less than 1 mw. For X-band ($1'' \times \frac{1}{2}''$) only. Includes 1N26 crystal, matched video load resistor.

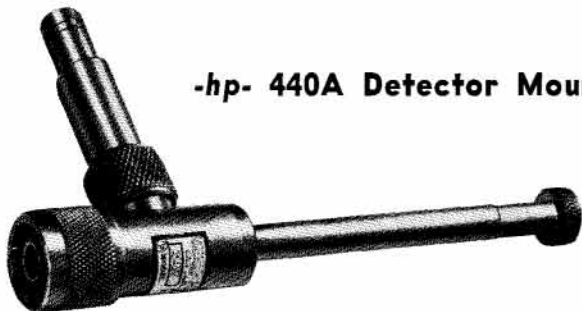

-hp- 440A Detector Mount

A simple, easily used instrument for detecting rf energy in coaxial or waveguide systems. In coaxial use, covers all frequencies 2.4 to 12.4 KMC. Uses either 1N21 or 1N23

silicon crystal, 1/100 amp. instrument fuse or Sperry 821 barretter. Simple single stub tuning. UG-21B/U rf input connector, BNC output jack. With -hp- 442B (below) becomes sensitive, easily tuned detector for slotted waveguide sections. (Detector element not furnished as a part of instrument.)

-hp- 442B Broad Band Probe

A probe whose penetration depth into a waveguide is variable, and position is fixed by a locking ring. Sampled rf appears at Type N jack, permitting direct connection to a receiver, spectrum analyzer, etc. With -hp- 440A (left) forms sensitive detector for slotted waveguides sections. Probe is shielded and provided with polyiron inserts to prevent spurious resonances. For $\frac{3}{4}$ " dia. mounting hole such as on -hp- 809B Universal Probe Carriage (Page 104).



-hp- 444A Untuned Probe

A 1N26 crystal plus a small antenna in a convenient housing permitting probe penetration to be varied quickly and easily. Probe position is fixed by a locking ring. Requires no tuning; and sensitivity surpasses most elaborate single and double-tuned probes (particularly between 8.0 and 18.0 KMC). Polyiron inserts damp spurious resonances. Frequency coverage 2.4 to 18.0 KMC; modified 1N76 crystal; BNC output jack. For $\frac{3}{4}$ " mounting hole as on -hp- 809B Carriage (Page 104).

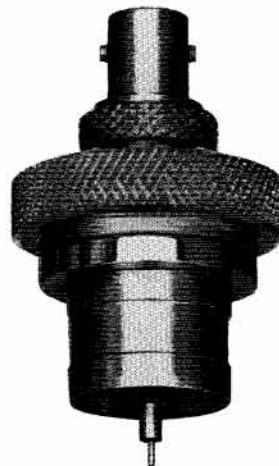

Data subject to change without notice.



530A MICROWAVE FREQUENCY METER



Reaction-Type General Purpose Meter for Lab or Production Use

THIS frequency meter is an inexpensive general purpose test instrument offering good accuracy over an entire waveguide band. It consists of a high Q resonant cavity which is tuned by a choke plunger. There are no sliding contacts. The cavity is mounted on a special waveguide section so designed that a small amount of power is reflected at resonance, while the major portion is transmitted. Resonance in the meter is indicated by a dip of approximately 20% in output. Reaction at resonance is approximately constant over the entire waveguide range, and there are no spurious modes or resonances.

Accuracy of Model 530A is better than 0.1%. It is tuned with a large standard micrometer unit. Readings may be quickly converted to determine frequency measured by reference to the standard calibration chart on the face of the instrument. For the finest degree of precision each instrument is provided with an individual calibration sheet containing provision for temperature correction of readings. Conducting surfaces are silver plated.

The J530 is available in a special J530B version which covers the important 5.20 to 7.05 KMC range in 1½" x ¾" waveguide.

Specifications

Model	Accuracy	Frequency Range KMC	Waveguide Size (in.)	Length (in.)
J530A	0.1%	5.85 - 8.20	1½ x ¾	4
J530B	0.1%	5.20 - 7.05	1½ x ¾	4
H530A	0.1%	7.05 - 10.00	1¼ x 5/8	3½
X530A	0.1%	8.20 - 12.40	1 x ½	3
P530A	0.1%	12.40 - 18.00	.702 x .391	3

Data subject to change without notice.

hp 752 DIRECTIONAL COUPLERS

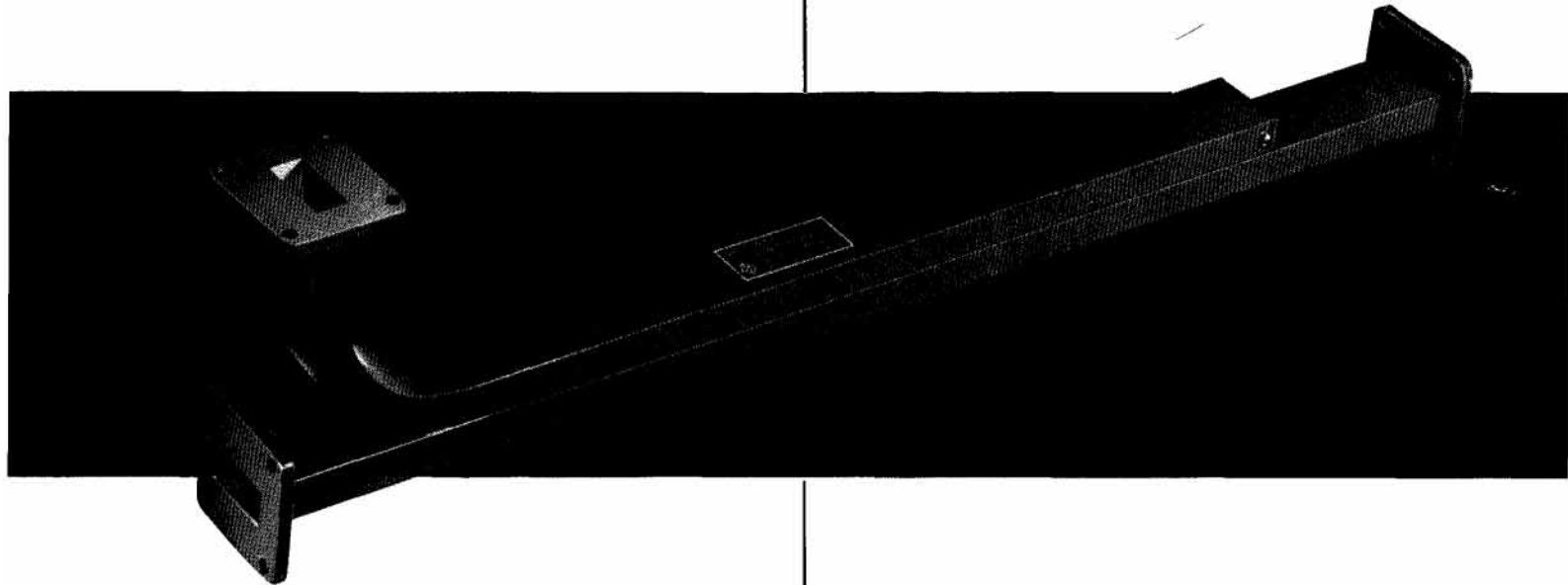

Easy-to-Use, Precision Couplers Simplify Waveguide Measurements

DIRECTIONAL couplers such as *-hp- 752* and *-hp- 750* are important tools in waveguide measurements. They may be used to monitor power, measure reflections, mix signals or isolate signal sources or wavemeters. They have the property of inducing into an auxiliary guide a power proportional to that flowing in the main guide. In addition, power flowing in one direction in the main guide induces uni-directional power in the auxiliary.

The ratio between power applied to the main guide and power delivered from the auxiliary is known as the "coupling factor" and is generally expressed in decibels (db). *Example: 20 db coupling means a ratio of powers of 100:1.*

The flow of coupled power in the auxiliary is ideally uni-directional; however, some reverse flow of power is unavoidable. The ratio between forward and reverse power in the auxiliary guide is termed the coupler's "directivity." This directivity is also expressed in db.

-hp- 752 Multi-Hole Couplers

In this *-hp-* Coupler, the broad faces of two waveguides are joined together. Coupling is obtained from a series of graduated holes. (*Figure 1.*) These holes are accurately machined in two rows along the broad faces of the wave-

guides. Power flowing down the primary guide couples through the holes, exciting waves which propagate in both directions in the auxiliary. The coupling holes are spaced $\frac{1}{4}$ wavelength apart, and thus waves traveling in the reverse direction are out of phase and cancel each other. Waves traveling in a forward direction reinforce each other. (*Figure 2.*)

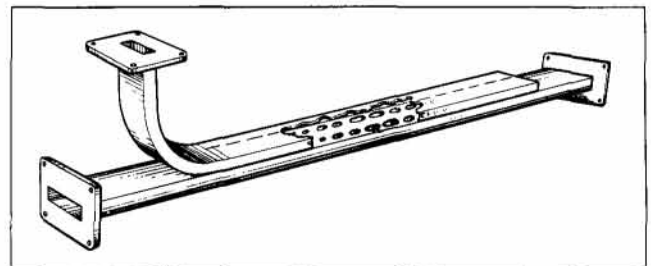

Figure 1. Construction, *-hp- 752* Directional Couplers.

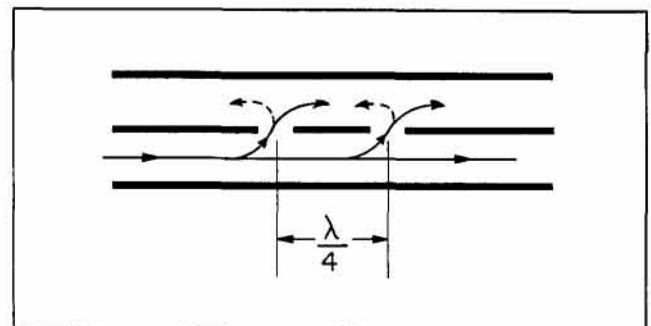

Figure 2. Cross-section, two-aperture coupler.

The auxiliary guide of Model 752 is terminated in a low reflection load at one end and in a plain cover flange at the other end. Detection of power in the auxiliary arm can be achieved readily by connecting a crystal detector or bolometer mount to the open end.

-hp- 752 has an overall directivity of better than 40 db (including reflection from built-in termination and flange) over the entire range of the guide. The coupling factors are 10 and 20 db; accuracy of mean coupling level is ± 0.4 db; and frequency sensitivity of coupling is ± 0.5 db over the waveguide frequency range.

Uses and Advantages

Because of its high directivity (Figure 3) this equipment is particularly suited for measurement of very small reflections, for rapidly adjusting transmission line flatness over the entire frequency range of the guide or for broadband reflectometer applications. (See pages 95-97 for discussion of reflectometer measurements.) With Model 752, a single oscilloscope presentation of SWR vs. frequency is easily made. In this operation, output of the auxiliary arm of the coupler is detected, amplified and applied to the vertical plates of the oscilloscope tube. The frequency applied to the system is swept and a voltage proportional to this frequency is applied to the horizontal plates of the oscilloscope. The resulting trace is a plot of reflection vs. frequency.



-hp- 750 Cross-Guide Couplers. For many applications the precision multi-hole coupler is not required. An inexpensive and compact instrument suited to numerous laboratory tests is -hp- 750 Cross-Guide Coupler.

This unit consists of two waveguide sections joined at right angles across their broad faces. It is available in coupling factors of 20 or 30 db, and connections may be made to both ends of the main and auxiliary guides. This provides a "four-terminal" network of maximum usefulness and versatility. The unit is well suited for power monitoring, for isolation and mixing powers.

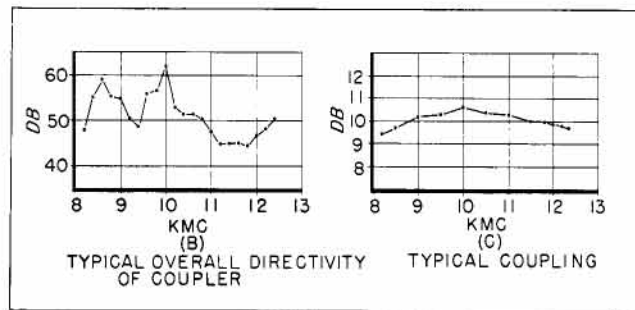

Figure 3. Characteristics, -hp- 752 Coupler - 10 db model.

Specifications

-hp- 752 Multi-Hole Couplers

Model	Coupling (db)	Frequency Range KMC	Waveguide Size (in.)	Approx. Length (in.)	Shipping Weight (lbs.)
S752C	10	2.6 - 3.95	3 x 1 1/2	39	75
S752D	20	2.6 - 3.95	3 x 1 1/2	39	75
G752A	3	3.95 - 5.85	2 x 1	30	23
G752C	10	3.95 - 5.85	2 x 1	30	23
G752D	20	3.95 - 5.85	2 x 1	30	23
J752A	3	*5.85 - 8.2	1 1/2 x 3/4	24	18
J752C	10	*5.85 - 8.2	1 1/2 x 3/4	24	18
J752D	20	*5.85 - 8.2	1 1/2 x 3/4	24	18
H752A	3	7.05 - 10.0	1 1/4 x 5/8	18 1/2	8
H752C	10	7.05 - 10.0	1 1/4 x 5/8	18 1/2	8
H752D	20	7.05 - 10.0	1 1/4 x 5/8	18 1/2	8
X752A	3	8.2 - 12.4	1 x 1/2	15 1/2	6
X752C	10	8.2 - 12.4	1 x 1/2	15 1/2	6
X752D	20	8.2 - 12.4	1 x 1/2	15 1/2	6
P752A	3	12.4 - 18.0	.702 x .391	12 1/4	4
P752C	10	12.4 - 18.0	.702 x .391	12 1/4	4
P752D	20	12.4 - 18.0	.702 x .391	12 1/4	4

Directivity: Better than 40 db over entire frequency range.

Coupling Accuracy: Mean coupling level is within ± 0.4 db of specified value.

Coupling Variation: Not more than ± 0.5 db over frequency range.

Primary Guide SWR: Less than 1.05 with "perfect" termination.

*J752 couplers operate to 5.3 KMC with reduced performance specifications. Directivity better than 40 db—5.85 to 5.5 KMC; better than 37 db—5.5 to 5.3 KMC. Coupling variation not more than -1.2 db at 5.5 KMC; -1.7 db at 5.3 KMC.

-hp- 750 Cross-Guide Couplers

Model	Coupling (db)	Frequency Range KMC	Waveguide Size (in.)	Physical Size (in.)	Shipping Weight (lbs.)
S750D	20	2.6 - 3.95	3 x 1 1/2	9 x 9	18
S750E	30	2.6 - 3.95	3 x 1 1/2	9 x 9	18
G750D	20	3.95 - 5.85	2 x 1	6 x 6	7
G750E	30	3.95 - 5.85	2 x 1	6 x 6	7
J750D	20	*5.85 - 8.20	1 1/2 x 3/4	5 x 5	4
J750E	30	*5.85 - 8.20	1 1/2 x 3/4	5 x 5	4
H750D	20	7.05 - 10.0	1 1/4 x 5/8	4 x 4	3
H750E	30	7.05 - 10.0	1 1/4 x 5/8	4 x 4	3
X750D	20	8.2 - 12.4	1 x 1/2	3 x 3	2
X750E	30	8.2 - 12.4	1 x 1/2	3 x 3	2

Directivity: Approximately 20 db or more.

Coupling Accuracy: Less than ± 1.7 db variation from nominal value over entire frequency range of guide.

*J750 couplers usable to 5.3 KMC. Directivity same as above. Coupling within ± 2 db of nominal value.

Data subject to change without notice.



WAVEGUIDE TEES

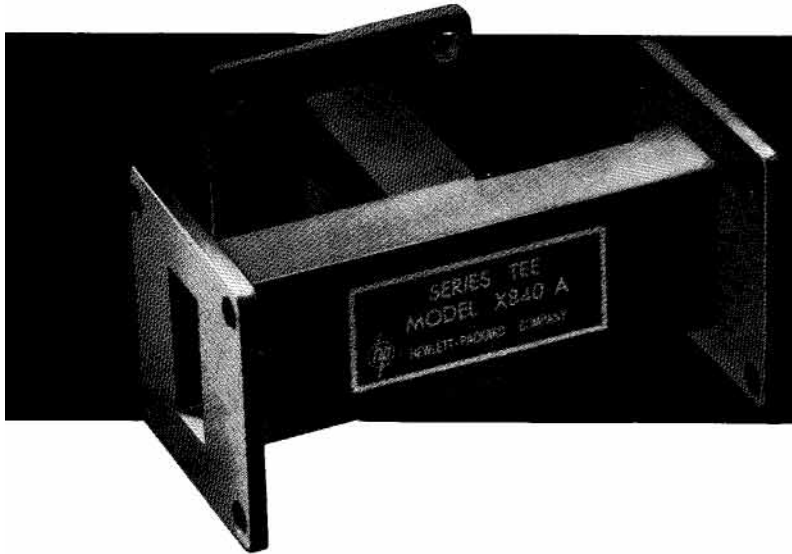

-hp- 840A/841A Series, Shunt Tees

Series and shunt tees simplify coupling waveguide networks in a waveguide system, or coupling auxiliary tuning impedances into the overall system. They facilitate division of power in the system; they also provide a convenient means of connecting a wavemeter or other detection device to the system.

Tees are supplied either as series or shunt elements. In series tees (Models 840A) the arm is joined to the broad face of the waveguide. In shunt tees (Models 841A) junction is made on the narrow face of the guide. Choice of a tee is usually made on mechanical considerations, as series and shunt tees can be arranged to provide equivalent electrical performance. Careful construction maintains centering and alignment of the elements.

Data subject to change without notice.

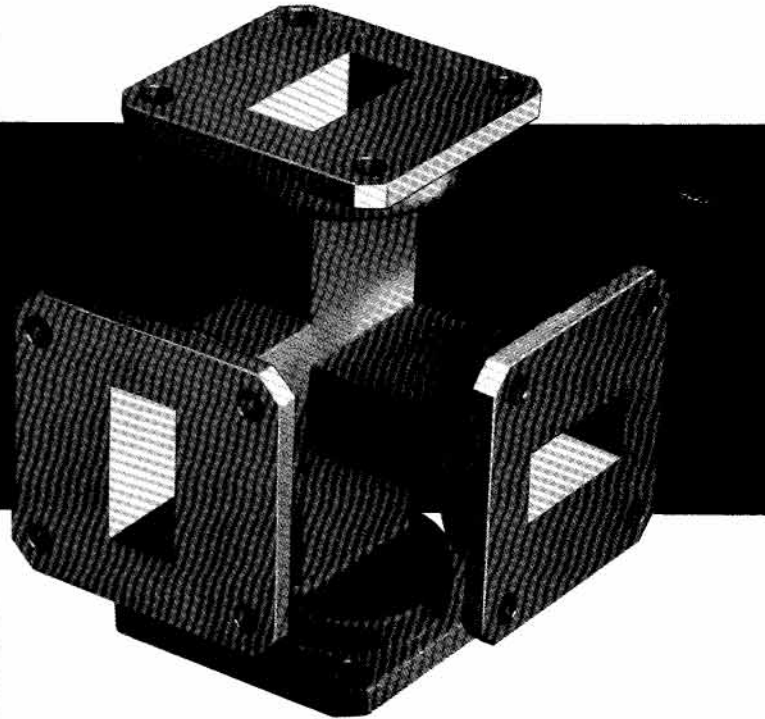

-hp- 845A Hybrid Tees

Hybrid tees speed and simplify determination of system SWR, comparison of impedances in transmission systems, and serve as a bridge circuit for balanced mixers.

-hp- 845A Hybrid Tees possess many of the properties of a bridge circuit. When power is applied to the shunt arm, and equal impedances placed on co-linear arms, no power appears at the series arm. When one of the co-linear arms is matched and the other mis-matched, and power is applied to the shunt arm, power appearing at the series arm is the measure of relative mis-match. Such measurements can be facilitated by terminating one or more arms with -hp- 920A Adjustable Shorts or -hp- 910A Terminations.

-hp- Hybrid Tees are carefully constructed for accurate balance between co-linear arms. No matching or balancing devices are employed. Where very accurate match is required, -hp- 752A Directional Coupler is recommended.

Specifications

-hp- 840A Series Tees			-hp- 841A Shunt Tees			-hp- 845A Hybrid Tees			Frequency Range KMC	Waveguide Size (in)
Model	Length (in)	Shipping Weight (lbs.)	Model	Length (in)	Shipping Weight (lbs.)	Model	Length (in)	Shipping Weight (lbs.)		
S840A	7 1/2	14	S841A	7 1/2	14	S845A	7 1/2	15	2.60-3.95	3 x 1 1/2
G840A	5 3/4	5	G841A	5 3/4	6	G845A	5 3/4	7	3.95-5.85	2 x 1
J840A	5 1/8	4	J841A	5 1/8	4	J845A	5 1/8	5	5.30-8.20	1 1/2 x 3/4
H840A	3 1/4	3	H841A	3 1/4	2	H845A	3 1/4	3	7.05-10.00	1 1/4 x 5/8
X840A	3 1/8	2	X841A	3 1/8	2	X845A	3 1/8	2	8.20-12.40	1 x 1/2
P840A	2 5/8	1	P841A	2 5/8	1	P845A	2 5/8	1	12.40-18.00	.702 x .391

hp WAVEGUIDE TUNERS

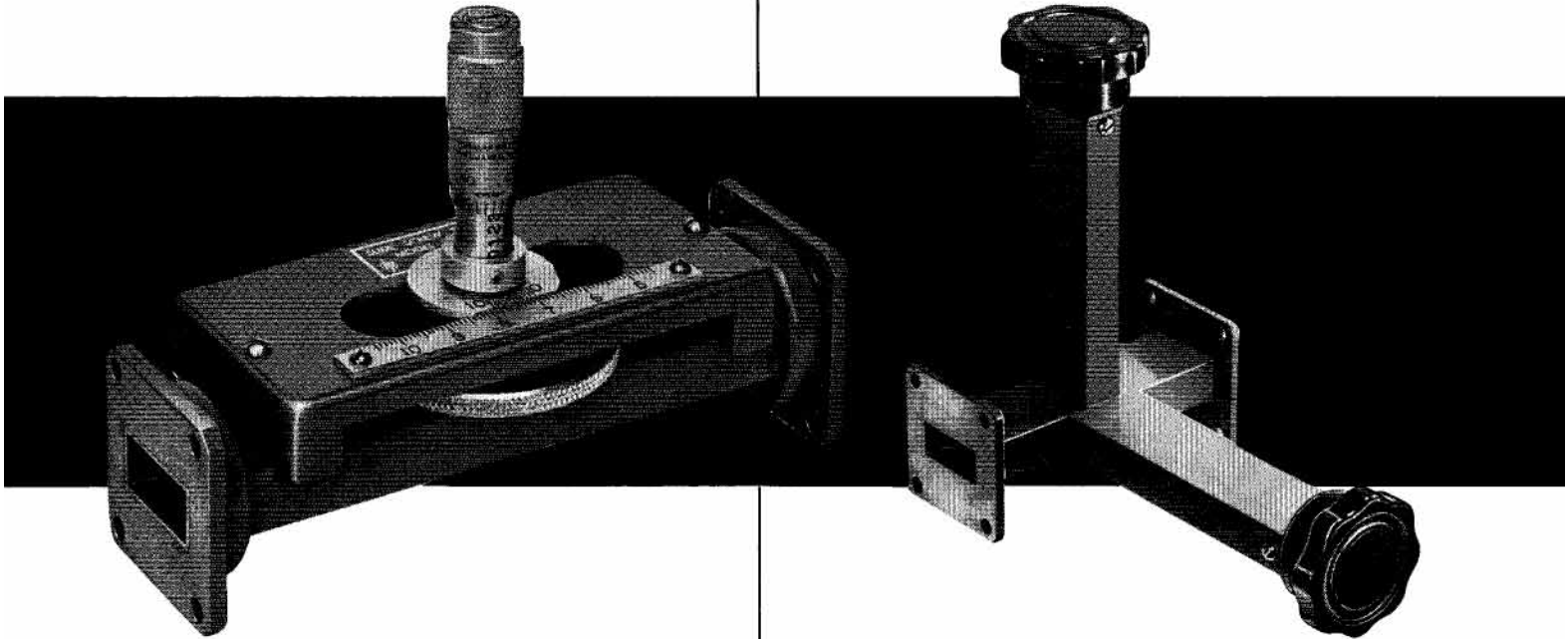

-hp- 870A Slide-Screw Tuners

Waveguide slide-screw tuners are used primarily for correcting discontinuities or "flattening" waveguide systems. They are also used to match loads, terminations, bolometer mounts or antennas to the characteristic admittance of the waveguide. They are particularly valuable in determining experimentally the position and magnitude of matching structures required in waveguide systems.

The tuners consist of a waveguide slotted section with a precision-built carriage on which is mounted an adjustable probe. The position and penetration of the probe is adjusted to set up an SWR which is used to cancel out existing SWR in a system. Probe insertion may be varied by means of a calibrated micrometer screw (except on S870A). The position of the probe is adjusted by a thumb-operated knurled-wheel vernier drive. SWR values of 20 can be corrected with an accuracy of 1.02, and small SWR's may be exactly corrected. Insertion loss at SWR of 20 is less than 2 db.

-hp- 880A E-H Tuners

Tuners of the E-H configuration are used to tune out discontinuities in waveguide systems or adjust residual SWR of loads, antennas, bolometer and crystal mounts. They are particularly useful where power leakage is undesirable or where very high powers are employed. With -hp- 880A Tuners, SWR's as high as 20 may be reduced to a value of less than 1.02. The insertion loss is low—only slightly more than an equivalent length of waveguide when the SWR is at unity. The loss increases linearly with SWR; and is less than 3 db when a mis-match of 20 is corrected.

-hp- 880A Tuners consist of a straight section of waveguide to which series and shunt tuning arms are attached. Each arm has a movable short circuit which may be adjusted by a fine tuning control.

Data subject to change without notice.

Specifications

-hp- 870A Slide-Screw Tuner			-hp- 880A E-H Tuner			Frequency Range KMC	Waveguide Size (in.)
Model	Length (in.)	Shipping Weight (lbs.)	Model	Length (in.)	Shipping Weight (lbs.)		
S870A	9 ⁷ / ₈	15	S880A	7 ¹ / ₈	22	2.60-3.95	3 x 1 ¹ / ₂
G870A	8 ¹ / ₄	7	G880A	6	13	3.95-5.85	2 x 1
J870A	8 ¹ / ₈	7	J880A	4	6	5.30-8.20	1 ¹ / ₂ x 3 ³ / ₄
H870A	6	4	H880A	3 ¹ / ₂	4	7.05-10.00	1 ¹ / ₄ x 5 ⁵ / ₈
X870A	5 ¹ / ₂	3	X880A	3 ¹ / ₂	3	8.20-12.40	1 x 1 ¹ / ₂
P870A	5	3	P880A	2 ¹ / ₄	3	12.40-18.00	.702 x .391

hp X885A WAVEGUIDE PHASE SHIFTER

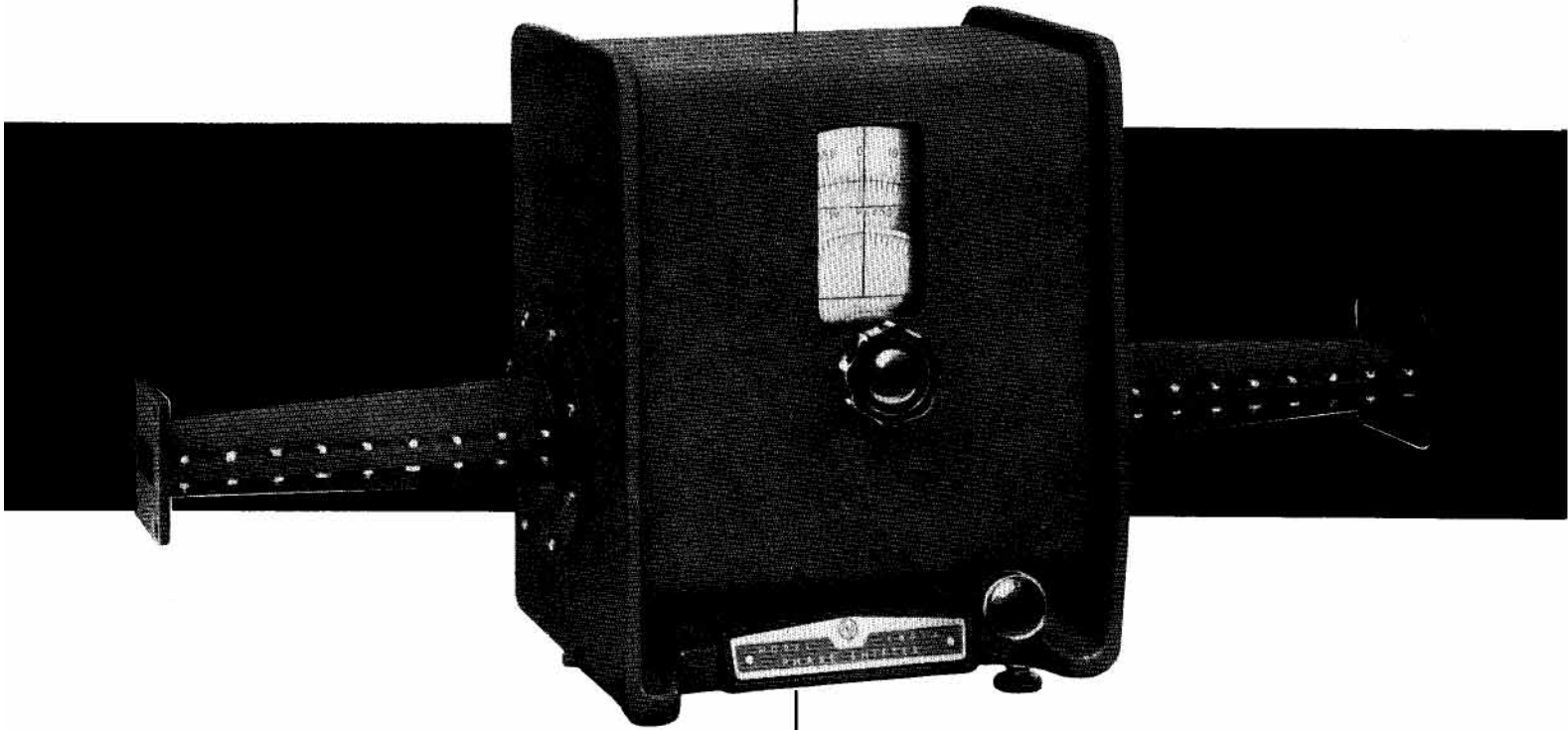

Specifications

Frequency Range: 8.2 to 12.4 KMC. Waveguide size 1" x 1/2". Flat cover flanges.

Phase Range: -360 to +360 electrical degrees.

Dial: Direct-reading, 2 divisions per degree.

Phase Error: Less than $\pm 2^\circ$ between any two phase settings, 8.2 to 10.0 KMC. Less than $\pm 3^\circ$ between settings 10.0 to 12.4 KMC. Error less than $\pm 10\%$ for phase difference less than 20° .

Insertion Loss: Less than 1 db, 8.2 to 10.0 KMC; less than 2 db, 10.0 to 12.4 KMC. Varies less than 0.3 db between phase settings, 8.2 to 10.0 KMC; less than 0.4 db between phase settings, 10.0 to 12.4 KMC. Insertion loss varies with frequency approximately 1 db over full frequency range.

Power: Maximum approximately 10 watts.

Dimensions: 15 1/2" long, 7 3/4" high, 4 1/2" deep.

Weight: 5 pounds. Shipping Weight approx. 19 pounds.

Data subject to change without notice.

Precision Phase Variation for X-Band Systems

MODEL -hp- X885A provides accurate, controllable phase variation in the X-band frequency range. It is particularly useful in measurement of transmission, attenuation and impedance in a microwave system, in introducing differential phase shift and in otherwise studying design of microwave systems and antennas. For example, the X885A Phase Shifter can be used in conjunction with an antenna array to optimize performance or to vary the directivity characteristics.

Full Range Operation

The instrument has a high accuracy over its entire phase range of -360 to +360 electrical degrees, and the full X-band frequency range of 8.2 to 12.4 KMC. (Waveguide phase shifters for other frequencies from 5.3 to 18.0 KMC are available.) Model X885A has low power absorption, is simple to operate, and requires no charts or interpolation. It is sturdily built, comprising two rectangular-to-circular waveguide transitions with a dial-driven circular waveguide mid-section. The instrument is housed in a cast-aluminum container for rigidity and durability.



WAVEGUIDE TERMINATIONS and HORNS

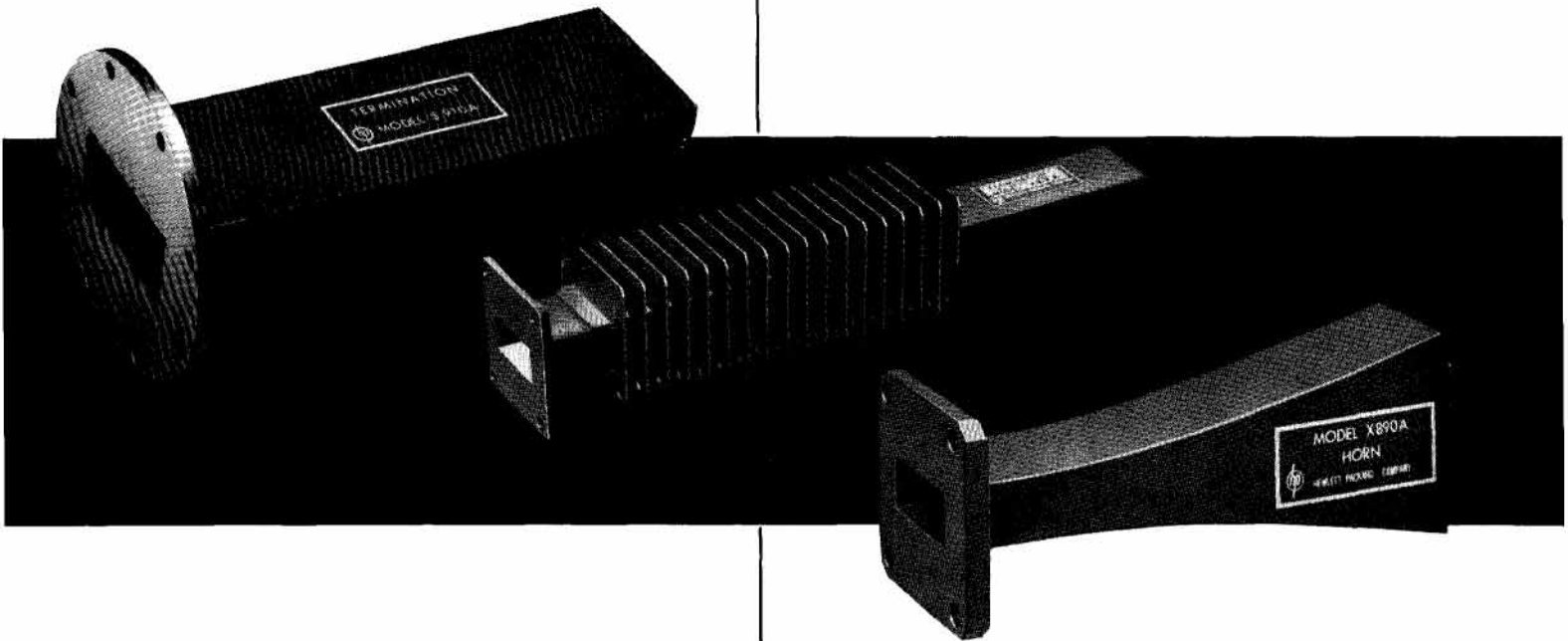

Model 910A Low Power Termination

Model 910A is designed for terminating waveguide systems operating at average powers of 1 watt, with a peak of 1 kw. The terminations are carefully designed to absorb virtually all of the applied power and assure a low SWR. They may be used wherever a matched load is required, as in the measurements of reflection, discontinuities or obstacles in waveguide systems. They are also for use with directional couplers or hybrid tees.

Mechanically, Model 910A consists of a waveguide section terminated in tapered lossy material which absorbs power in the waveguide. Careful design results in minimum reflection over the entire waveguide band.

Model 912A High Power Termination

This termination is similar to Model 910A but is designed for waveguide systems operating at high powers. Since these terminations readily absorb large amounts of power, they are useful as dummy loads in testing vacuum tube characteristics, transmitter output, etc. Model 912A Terminations contain a high loss material which absorbs power and is carefully tapered to keep SWR low. Power is dissipated by cooling fins. When the termination is operated at 50% or more of rated power, fins should be forced-air cooled.

Model 890A Waveguide Horn

Model 890A is essentially a coupler from a waveguide system to air. It is a convenient device for use in laboratories or for instructional purposes.

Specifications

-hp- 910A Low Power Termination					-hp- 912A High Power Termination					-hp- 890A Waveguide Horn		Frequency Range KMC	Waveguide Size (in.)
Model	Max. SWR	Average Power Watts	Peak Power kw	Length (in.)	Model	Max. SWR	Average Power Watts	Peak Power kw	Length (in.)	Model	Length (in.)		
S910A	1.06	1	1	10 ³ / ₄	S912A	1.1	100	100	15 ³ / ₄			2.60 - 3.95	3 x 1 ¹ / ₂
G910A	1.06	1	1	6 ⁵ / ₈								3.95 - 5.85	2 x 1
J910A	1.02	1	1	6 ¹ / ₄								5.30 - 8.20	1 ¹ / ₂ x 3 ³ / ₄
H910A	1.02	1	1	4 ⁵ / ₈								7.05 - 10.00	1 ¹ / ₄ x 3 ⁵ / ₈
X910A	1.02	1	1	5 ¹ / ₂	X912A	1.1	50	50	8 ¹ / ₄	X890A	4 ¹ / ₂	8.20 - 12.40	1 x 1 ¹ / ₂
P910A	1.02	1/2	1/2	4 ¹ / ₄						P890A	3 ³ / ₄	12.60 - 18.00	.702 x .391

Data subject to change without notice.



WAVEGUIDE LOADS

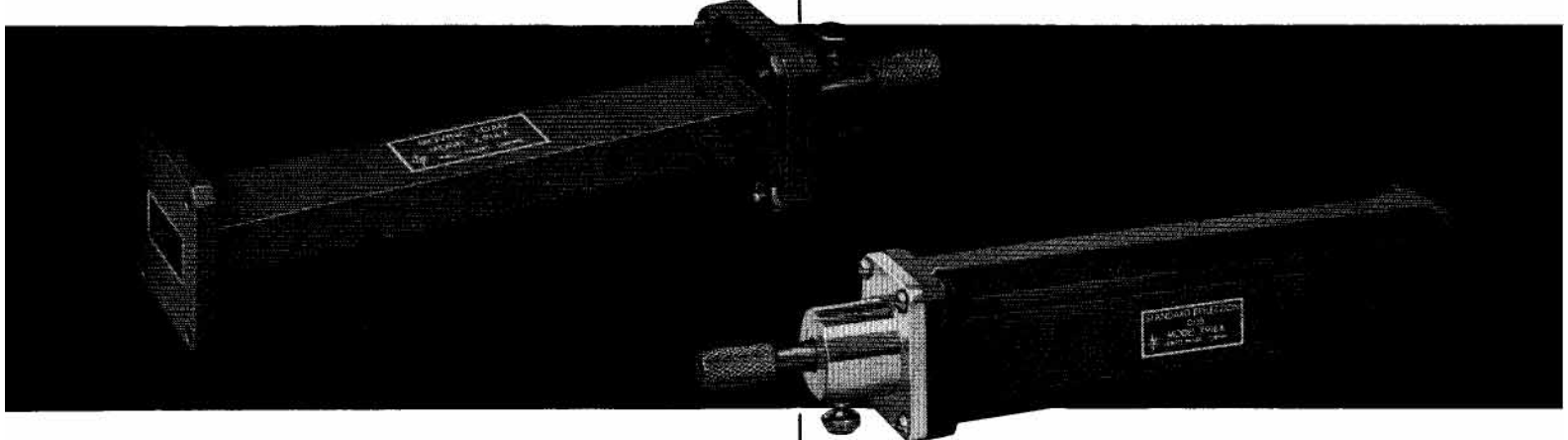

-hp- 914A Moving Load

Model 914A Moving Load consists of a section of waveguide in which is mounted a sliding, tapered, low-reflection load. A plunger controls the position of the load which is variable at least $\frac{1}{2}$ wavelength at the lowest waveguide frequency. This permits reversing the phase of the residual reflection so that this reflection can be separated from the other small reflections in the waveguide system.

In Model 914A the reflection of the load is less than $\frac{1}{2}\%$ over the full frequency range of the waveguide.

Specifications

Model	Frequency Range KMC	Waveguide Size (in.)	Overall Length (in.)	Shipping Weight (lbs.)
S914A	2.60 - 3.95	3 x 1½	24	21
G914A	3.95 - 5.85	2 x 1	15¼	10
J914A	5.30 - 8.20	1½ x ¾	11¾	9
H914A	7.05 - 10.00	1¼ x ¾	9½	4
X914A	8.20 - 12.60	1 x ½	8¼	3
P914A	12.60 - 18.00	.702 x .391	8	1

Data subject to change without notice.

-hp- 916A-E Standard Reflections

Model 916 Standard Reflections are new precision loads used to set up exact reflections for standardizing SWR measuring setups. Specifically designed for measurements in the important X band, the new loads are available in 5 reflection coefficient values ranging from 0.00 to 0.20.

The instrument consists of a precision machined aluminum casting whose inside wide dimension is the same as that of a standard X band waveguide but whose inside narrow dimension is reduced by the exact amount necessary to establish the required power reflection at the junction of the waveguide. The precision taper load is movable so that small reflections which it causes can be isolated from the calibrated discontinuity.

Specifications

Model	Nominal Reflection Coefficient	Accuracy (Reflection Coefficient)
X916A	.00	±0.002
X916B	0.05	±0.0025
X916C	0.10	±0.0035
X916D	0.15	±0.0045
X916E	0.20	±0.007

Waveguide Size: 1" x ½", flat cover flanges.

Frequency Range: 8.2 to 12.4 KMC.

Dimensions: 1⅝" x 1⅝" x 8⅜" long.

Weight: 2 lbs., packed for shipment.



WAVEGUIDE SHORTS

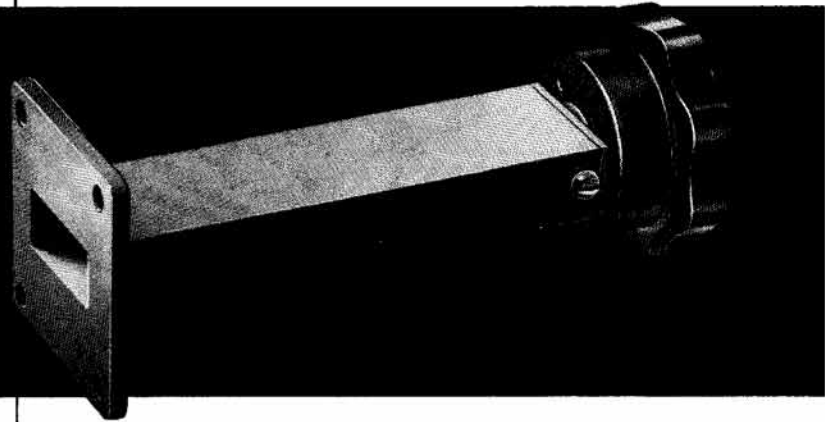
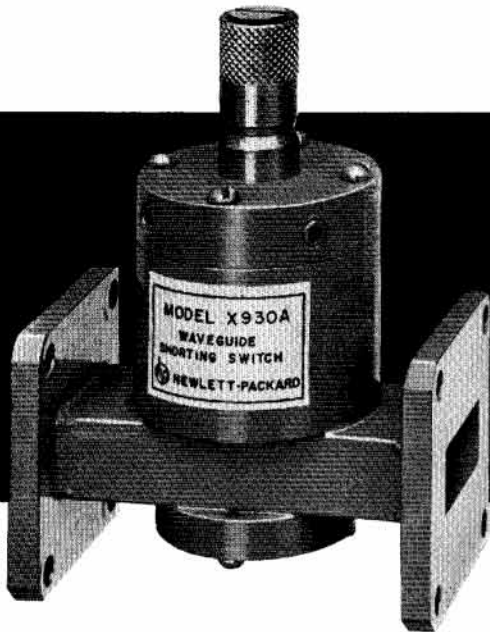

-hp- X930A Waveguide Shorting Switch

The -hp- Waveguide Shorting Switch is a time-saving means of establishing a removable short-circuit in a waveguide system. It is especially useful in power measuring setups where it can temporarily interrupt the power flowing into a bolometer mount for zero-setting a Microwave Power Meter such as the -hp- 430C. It can also be used to establish a reference reflection coefficient of 1.00 for calibrating Ratio Meters such as the -hp- 416A. The low insertion loss and SWR of the -hp- X930A make it adaptable to nearly all measuring applications of this type.

Specifications

- SWR:** Less than 1.02 in "open" position.
- Rejection Ratio:** Greater than 50 db.
- Insertion Loss:** Less than 0.05 db in "open" position.
- Waveguide:** 1" x 1/2", RG-52/U; Flanges UG-39/U.
- Frequency Range:** 8.2 - 12.4 KMC.
- Length:** 2 5/8".
- Shipping Weight:** Approximately 2 lbs.

Data subject to change without notice.

-hp- 920A Adjustable Shorts

Adjustable shorts are convenient instruments for introducing a variable element in waveguide systems. In conjunction with a slotted section, they can be used to provide a variable short-circuit reference point. With a waveguide tee section, they can form a stub-transformer or tuner providing variable reactance. They may also be used as a convenient tuner for crystal or bolometer mounts.

Mechanically, -hp- 920A Shorts are a waveguide section in which a movable low loss contacting finger wiper* is mounted. Position of the short is varied by a fine tuning control.

Specifications

Model	Length	Frequency Range KMC	Waveguide Size (in.)	Shipping Weight (lbs.)
S920A	10 1/2	2.60 - 3.95	3 x 1 1/2	10
G920A	7 1/2	3.95 - 5.85	2 x 1	4
J920A	3 1/4	5.30 - 8.20	1 1/2 x 3/4	3
H920A	3 1/2	7.05 - 10.00	1 1/4 x 5/8	2
X920A	4 1/2	8.20 - 12.40	1 x 1/2	2
P920A	4 1/2	12.40 - 18.00	.702 x .391	1

*In the "P" band a choke-type short is employed. Position of the choke is varied by a micrometer adjustment.

METAL CABINETS, RACK MOUNT, END FRAMES

STANDARD *-hp-* instruments can be mounted any of three convenient ways—in new, streamlined all metal cabinets, with end frames, or in your relay rack and later remounted any other way quickly, conveniently with only minor modifications. This versatility means maximum usefulness from your *-hp-* equipment and increased flexibility of your entire instrument setup.

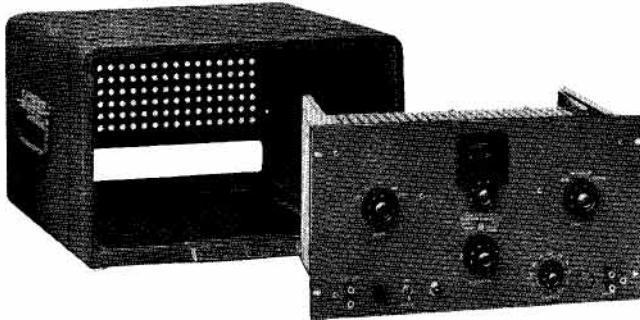

Cabinets. Hewlett-Packard instruments with standard 10½" x 19" panels are available in standardized *-hp-* AC-44 aluminum-and-steel cabinets. Equipped with sturdy carrying handles, AC-44 cabinets give your instruments greater protection, better ventilation, more convenience and a clean, rugged, modern appearance. The cabinets feature a separate back cover which may be removed individually. The cabinet itself may also be removed quickly and easily. Cabinets are finished in wrinkle grey, matching *-hp-* grey baked enamel panel faces.

-hp- AC-44 cabinets are available with the following instruments either when factory shipment of instrument is made or separately to fit your present *-hp-* instrument.

100D	206A	330D	624C
202A	212A	416A	650A
202B	330B	520A	712B
205AG	330C	522B	

-hp- AC-44 cabinets measure (outside dimensions) 20¾" wide, 12" high, 14" deep. Weight is approximately 15 pounds. When inquiring about cabinets for instruments you now have, please include model and serial number.

Cabinet, with instrument, \$15.00; separately, \$25.00.

End Frames. To increase flexibility and convenience of your *-hp-* instruments for bench use, *-hp-* AC-17 End Frames are offered. These frames are of heavy gauge aluminum, equipped with sturdy carrying handles and finished in *-hp-* grey baked

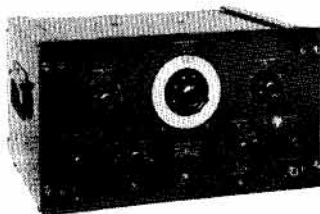

enamel. They fit all late model *-hp-* instruments with panel size 10½" x 19" except *-hp-* Model 520A, and may be attached in a matter of moments.

-hp- AC-17 End Frames, set, \$7.50.

Rack Mounting. Many *-hp-* instruments are basically rack mounting, and can be installed directly into standard 19" relay racks. Many other *-hp-* instruments can be equipped for rack mounting at slight additional cost. A complete list of instruments available for rack mounting will be supplied on request; or make special inquiry concerning instruments you are interested in.

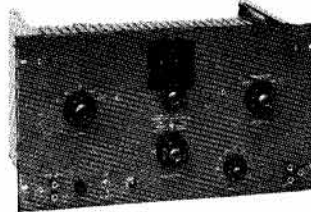

Smaller *-hp-* Instruments. Small *-hp-* instruments such as *-hp-* 400D Vacuum Tube Voltmeter (illustrated) are also supplied in streamlined all-metal cabinets. As with large size *-hp-* cabinets, the small cabinets provide greater protection, better ventilation, more convenience and a more pleasing appearance. Cabinets are finished in wrinkle grey matching the *-hp-* grey



baked enamel panel faces, and are equipped with a sturdy leather carrying handle. Instruments supplied with these cabinets as standard equipment include *-hp-* 400D, 400AB and 410B Vacuum Tube Voltmeters, 200AB and 200CD Audio Oscillators, 512 A/B Frequency Converters, 715A and 717A Klystron Power Supplies, and 490A and 491A Traveling-Wave Tube Amplifiers.

***-hp-* AC-2A Dual Mount**

As a convenience to customers who wish to combine any two of the smaller *-hp-* instruments into one rack mounting, *-hp-* AC-2A Dual Mount is offered. Measuring 10½" x 19" overall, this mount is designed to accept any two of the following instruments, *-hp-* 400D, 400-AB, 410B, 200AB, 200CD and 512A/B. *-hp-* AC-2A, supplied separately, \$25.00; instruments installed at factory, \$35.00.

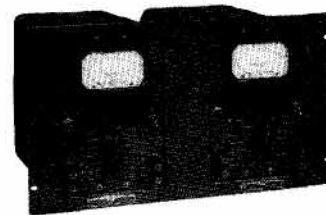

Data subject to change without notice. Prices f.o.b. factory.

-hp- AC-60A/B Line Matching Transformers

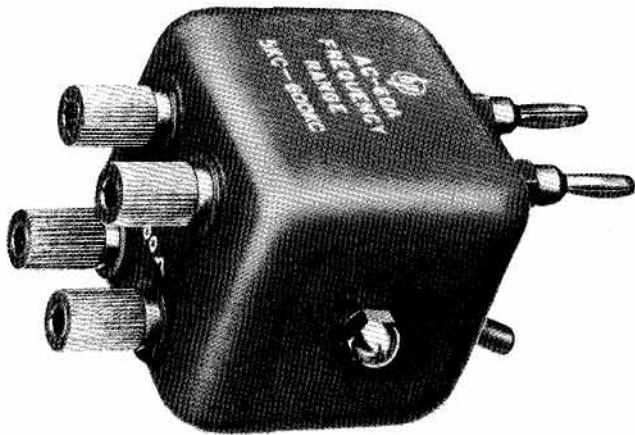

Model AC-60A

Model AC-60A is specifically designed to connect a balanced system to -hp- 200CD Audio Oscillators, 400D Vacuum Tube Voltmeters, or similar equipment, for carrier current or other measurements between 5 and 600 KC. With -hp- 200CD it provides fully balanced 135 or 600 ohm output with attenuator in use. With -hp- 400D it provides voltage measurements on either a 135 or 600 ohm balanced line without grounding of one side, and permits bridging or terminated voltage measurements on both 135 and 600 ohm lines. Maximum level + 22 dbm. Shipping weight 2 lbs. \$25.00.

Model AC-60B is similar to the AC-60A except that it is for use in audio systems, being specifically designed for connecting -hp- 330B Noise and Distortion Analyzer to a balanced line. Frequency range is 20 cps to 60 KC; maximum level is + 15 dbm. Shipping weight 6 lbs. \$35.00.

-hp- AC-10A/B Binding Posts

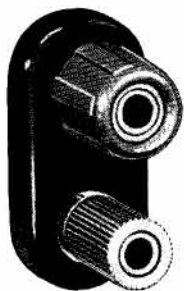

Designed by -hp-, these posts insure a positive connection that can be changed quickly and easily. The recess for "banana" plugs is in the main body of the post to eliminate excessive contact resistance. The cross-hole for permanent connection may be used even when a plug is inserted. The posts have an axially-knurled ferrule with 10/32 thread and a tip undercut to simplify soldering. Posts are offered as Model AC-10A (non-insulated) at \$.20 each; and as Model AC-10B (insulated) at \$.30 each. (Cap of insulated post is 9/16" long with outside diameter of 9/16".)

-hp- AC-54A/B/C Insulators

These binding post insulators are of three standard designs. Model AC-54A is a double insulator, 1 1/2" x 3/4", offered in black bakelite only. Model AC-54B is a triple insulator, 2 3/4" x 3/4", black or red. Model AC-54C is a triangular triple insulator, 1 1/2" on each side of triangle, red or black. All insulators are 1/4" thick. Holes are spaced 3/4" apart. Minimum hole diameter 0.190" with a 7° taper. -hp- AC-54A, \$.15 each. -hp- AC-54C, \$.20 each. -hp- AC-54B, \$.20 each.



-hp- AC-54B



-hp- AC-54C

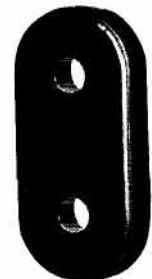

-hp- AC-54A

-hp- AC-24 Waveguide Stand (below)

Model AC-24 Waveguide Stands are cast and machined from aluminum alloy. They are designed for -hp- 25 Waveguide Clamps and have a threaded screw which locks the clamp at any height from 2 3/4" to 5 1/4". Model AC-24 is 2 1/2" high and its base measures 4 3/4" in diameter. \$3.00 each.

-hp- 25 Waveguide Clamps

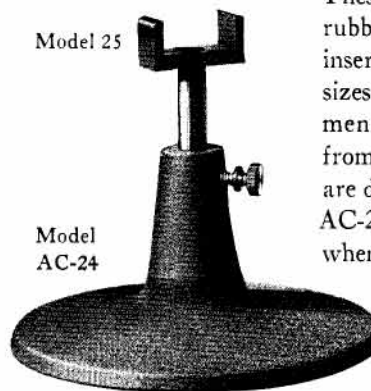

Model 25

Model AC-24

These Clamps consist of a rubber molding with a steel insert. They are offered in 6 sizes to fit waveguide equipment covering frequencies from 2.6 to 18.0 KMC. They are designed for use with -hp- AC-24 Waveguide Stand, and when mounted in the Stand can be adjusted upward or downward to conform with a waveguide set-up.

When ordering, specify waveguide size. Model S25, 3" x 1 1/2"; Model G25, 2" x 1"; Model J25, 1 1/2" x 3/4"; Model H25, 1 1/4" x 5/8"; Model X25, 1" x 1/2"; Model P25, .702" x .391". \$1.50 each.

*Data subject to change without notice. Prices f.o.b. factory.
Quantity discount prices on request.
Instruments finished in -hp- grey baked enamel.*



ACCESSORY CABLE ASSEMBLIES

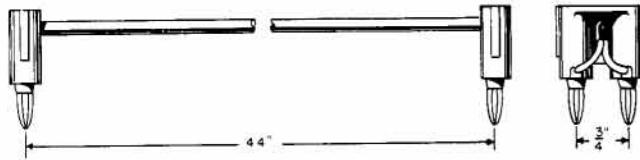

AC-16A Cable Assembly. Equipped with two dual banana plugs, this cable consists of 4 feet of RG-58/U 50 ohm coaxial cable. Plugs are for binding posts spaced $\frac{3}{4}$ " between centers. Each \$4.00.

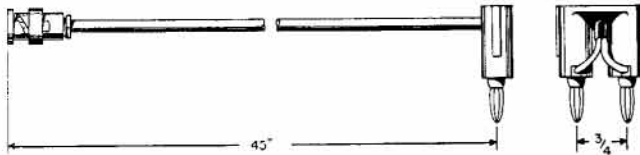

AC-16B Cable Assembly. Identical with AC-16A except has dual banana plug ($\frac{3}{4}$ " center) on one end and UG-88/U Type BNC male connector on other end. Length overall, 45". Each \$4.25.

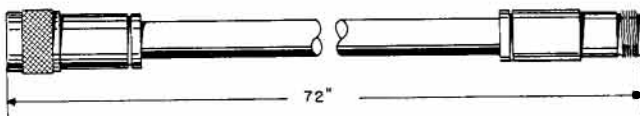

AC-16C Cable Assembly. This cable consists of 6 feet of RG-9A/U 50 ohm coaxial cable terminated on one end with UG-21B/U Type N male connector and UG-23B/U Type N female connector at opposite end. For use at frequencies below 4,000 MC. Each, \$7.50.

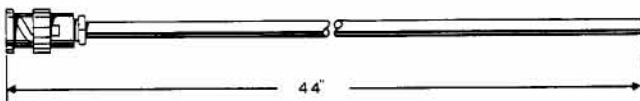

AC-16D Cable Assembly. This cable consists of 44 inches of RG-58/U 50 ohm coaxial cable terminated on one end only. Termination is UG-88/U Type BNC male connector. Each, \$2.65.

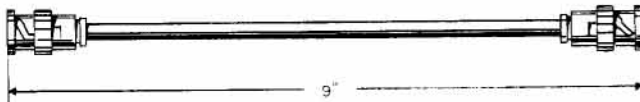

AC-16E Cable Assembly. A short cable of 9 inches length consisting of RG-58/U 50 ohm coaxial cable terminated on both ends with UG-88/U Type BNC male connectors. Each, \$4.50.

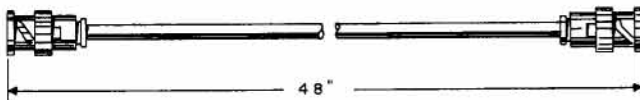

AC-16K Cable Assembly. This cable consists of 4 feet of RG-58/U 50 ohm coaxial cable terminated on each end with UG-88/U Type BNC male connectors. Each, \$5.00.

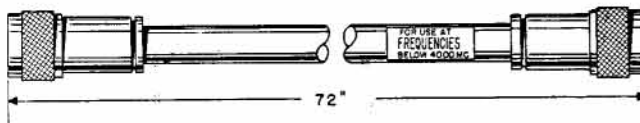

AC-16F Cable Assembly. For use at frequencies below 4,000 MC. Consists of 6 feet of RG-9A/U 50 ohm coaxial cable terminated on each end with UG-21B/U Type N male connectors. Each, \$7.50.

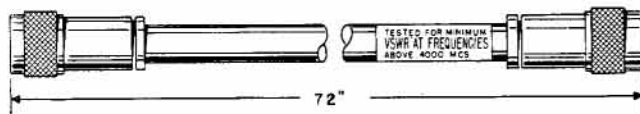

AC-16Q Cable Assembly. For use at frequencies above 4,000 MC. Consists of 6 feet of specially treated RG-9A/U 50 ohm coaxial cable terminated on each end with UG-21D/U Type N male connectors. Each cable tested and selected for minimum SWR at frequencies above 4,000 MC. Each, \$12.00.

Prices f.o.b. factory.

Data subject to change without notice.



Warranty

Hewlett-Packard Company warrants each instrument of its manufacture to be free from defects in material and workmanship. Our obligation under this Warranty is limited to servicing or adjusting any instrument returned to our factory for that purpose, and to making good at our factory any part or parts thereof except tubes, fuses or batteries which shall, within one year after making delivery to the original purchaser, be returned to us with transportation charges prepaid, and which on our examination shall disclose to our satisfaction to have been thus defective.

Hewlett-Packard reserves the right to make changes in design at any time without incurring any obligation to install same on units previously purchased.

This Warranty is expressly in lieu of all other obligations or liabilities on the part of Hewlett-Packard, and Hewlett-Packard neither assumes nor authorizes any other person to assume for them any other liability in connection with the sales of Hewlett-Packard instruments.

STANDARD WAVEGUIDE FLANGE SPECIFICATIONS

-hp- designations (1)	WAVEGUIDE		Material	Frequency Range (KMC) for Dominant (TE ₁₀) Mode	DIMENSIONS, IN INCHES			
	RETMA Designation	JAN Type			Inner Dimensions		Outer Dimensions	
					Width	Height	Width	Height
S	WR284	RG-48/U RG-75/U	Brass Aluminum	2.60 - 3.95	2.840	1.340	3.000	1.500
G	WR187	RG-49/U RG-95/U	Brass Aluminum	3.95 - 5.85	1.872	0.872	2.000	1.000
C	WR159		Brass Aluminum	4.9 - 7.05	1.590	0.795	1.718	0.923
J	WR137	RG-50/U RG-106/U	Brass Aluminum	5.3 - 8.20	1.372	0.622	1.500	0.750
H	WR112	RG-51/U RG-68/U	Brass Aluminum	7.05 - 10.00	1.122	0.497	1.250	0.625
X	WR90	RG-52/U RG-67/U	Brass Aluminum	8.20 - 12.40	0.900	0.400	1.000	0.500
M	WR75		Brass Aluminum	10.00 - 15.00	0.750	0.375	0.850	0.475
P	WR62	RG-91/U RF-107/U	Brass Silver	12.40 - 18.00	0.622	0.311	0.702	0.391
N	WR51		Brass Silver	15.00 - 22.00	0.510	0.255	0.590	0.335
K	WR42	RG-53/U RG-66/U	Brass Silver	18.00 - 26.50	0.420	0.170	0.500	0.250
Q	WR34		Brass Silver	22.00 - 33.00	0.340	0.170	0.420	0.250
R	WR28	RG-96/U	Silver	26.50 - 40.00	0.280	0.140	0.360	0.220

NOTES:

- (1) -hp- waveguides are machined from brass. Outside surfaces are finished in -hp- grey baked enamel. Conducting surfaces are plated with a bright, high-conductivity alloy or silver where sliding finger contacts are used.
- (2) Resistivity of Brass— 7.0×10^{-6} ohm - cm.
Resistivity of Aluminum— 2.83×10^{-6} ohm - cm.
Resistivity of Silver— 1.62×10^{-8} ohm - cm.

STANDARD WAVEGUIDE ~~AND~~ FLANGE SPECIFICATIONS

Wall Thickness Nominal	Cut-Off Frequency of TE ₁₀ Mode (KMC)	Theoretical Attenuation Lowest to Highest Freq. (db/100 Ft.) (2)	WAVEGUIDE FLANGES (3) Aluminum		WAVEGUIDE FLANGES (3) Bronze	
			Cover Type JAN No.	Choke Type & Gasket JAN No.	Cover Type JAN No.	Choke Type & Gasket JAN No.
0.080	2.080	1.478 - 1.008 0.940 - 0.641	UG-584/U	UG-585/U	UG-53/U	UG-54A/U
0.064	3.155	2.79 - 1.93 1.77 - 1.22	UG-407/U	UG-406A/U	UG-149A/U	UG-148B/U
0.064	3.714	2.89 - 2.24 1.84 - 1.42				
0.064	4.285	4.61 - 3.08 2.93 - 1.94	UG-344/U	UG-343A/U	UG-441/U	UG-440A/U
0.064	5.260	5.51 - 4.31 3.50 - 2.74	UG-138/U	UG-137A/U	UG-51/U	UG-52A/U
0.050	6.560	8.64 - 6.02 5.49 - 3.83	UG-135/U	UG-136A/U	UG-39/U	UG-40A/U
0.050	7.880	10.1 - 7.12 6.42 - 4.52				
0.040	9.490	12.76 - 11.15 6.14 - 5.36			UG-419/U	UG-541/U
0.040	11.590	17.5 - 12.7 8.43 - 6.12				
0.040	14.080	27.7 - 19.8 13.3 - 9.5			UG-595/U	UG-596/U
0.040	17.37	33.3 - 23.2 16.1 - 11.2				
0.040	21.100	21.9 - 15.0			UG-599/U	UG-600/U

(3) All -hp- flanges are plain contact type. Where mating choke type connection is required, use -hp- 290A Cover to Choke Flange Adapter.

INDEX BY INSTRUMENT TITLE

<i>Instrument</i>	<i>Page</i>	<i>Instrument</i>	<i>Page</i>
Accessories	116, 117, 118	Carriage, Universal Probe	104, 105
AC Voltmeters	31-37	Carrier Test Oscillators	16
Adapters:		Choke to Cover Flange Adapter	85
460A/B Accessories	41	Clamps, Waveguide	117
Cover to Choke Flange	85	Coaxial:	
Waveguide to Coaxial	85	Adapter	37, 85
Adjustable Short, Waveguide	115	"N" and "T" Connectors	37
Amplifiers:		Detector Mount	106
Bridging	38	Low Pass Filter	86
Distributed Wide Band	40, 41	Slotted Sections	102-105
Fast-Pulse	40, 41	Connector Sleeve	41
General Purpose	38	Converters, Frequency	61
Traveling-Wave Tube	42, 43	Cord, Patch	41
Analyzers, Distortion and Waveform	25-29	Counter:	
Attenuators:		Decade	60
Calibrated, Waveguide	87	Electronic	54, 59
Decade	30	Industrial Electronic	59
Fixed, Waveguide	87	Couplers - Directional:	
Precision	88	Cross-Guide Coupler	108, 109
Variable Flap, Waveguide	87	Multi-hole Coupler	108, 109
Audio Frequency Distortion Analyzers:		DC Voltage Multiplier	37
Distortion Analyzer	28, 29	DC Voltmeter	34, 35
Waveform Analyzer	26, 27	Decade Attenuator	30
Audio Frequency Oscillators	5-16	Decade Counter	60
Audio Frequency Signal Generators:		Detector Mounts:	
High Power Audio Tests	18, 19	Waveguide	94
High Quality, High Accuracy Tests	20, 21	Coaxial	106
Band-Spread Oscillator	8, 9	Detector, vhf	101
Binding Posts, Insulated; Insulators	117	Directional Couplers	108, 109
Bolometer Mounts: Tunable-Universal	92	Distortion Analyzers	25-29
Bridge, vhf	100, 101	Distortion and Noise Meter	28, 29
Bridged-T Attenuator	30	Distributed Amplifier	40, 41
Bridging Amplifier	38	E-H Tuner	111
Bridging Transformer	117	Electronic Counter	54, 59
Broadband Probe	106	Electronic Tachometer	48, 49, 52
Cabinets, Metal	116	Fast-Pulse Amplifier	40, 41
Cables	118	Filters, Low Pass	86
Calibrated Attenuator	87	Fixed Waveguide Attenuator	87
Capacitive Voltage Divider	37	Flanges, Waveguide	120, 121
		FM Monitor	50, 51

<i>Instrument</i>	<i>Page</i>	<i>Instrument</i>	<i>Page</i>
Frequency:		Monitors:	
Counter	54, 59	Frequency	50, 51, 54-58
Converter	61	Aural, FM, Video	50, 51
Meters	48, 49	Moving Load	114
Monitor	50, 51	Multi-hole Coupler	108, 109
Scaler	62	N-Connector, Probe to Coaxial	37
Standard	46, 47	Noise:	
Function Generator, Low Frequency	10, 11	Analyzer	26, 27
Generators:		Generator	22, 23
Signal (See Signal Generators)		Meter	28, 29
Pulse	22, 23	Nuclear Scaler	62
Square Wave	24	Ohmmeter	34, 35
Tachometer	52	Optical Tachometer Pickup	52
Hardware, -hp-	117	Oscillators:	
Harmonic Analyzer	26, 27	Audio Tests	8, 9
High Power Waveguide Terminations	113	Audio and Supersonic	8, 9
Hybrid Tees, Waveguide	110	Carrier Tests	8, 9, 16
Impedance Transformer	41	High Quality Audio Tests	12
Indicator, Standing Wave	102	Interpolation and Frequency Measurement	8, 9
Industrial Electronic Counter	59	Low Frequency Measurements	8-11, 13
Insulated Binding Posts	117	Sweep	76, 77
Insulators for Binding Posts	117	Telemeter	9
Interpolation Oscillator	8, 9	Wide-Range, Video Tests	14, 15
Jack, Panel	41	Panel Jack	41
JAN Standard Tables	120, 121	Patch Cord	41
Klystron Power Supply	81, 82	Phase Shifter	112
Laboratory Amplifier (See Amplifiers)		Plug Cable	41
Line Matching Transformer	117	Power Meter	91
Load, Moving	114	Power Supplies:	
Low Frequency:		General Purpose	78-80
Function Generator	10, 11	Klystron	81
Oscillators	8-15	Pre-Scope Amplifier	38-41
VTVM	31, 37	Probes:	
Low Pass Filters	86	Broadband	106
Low Power Waveguide Terminations	113	Untuned	106
Low Reflection Load	114	Probe Carriage, Universal	104
Meters:		Probe to Coaxial Connectors	37
Distortion	28, 29	Pulse Counter	54, 55, 62
Frequency	48, 49	Pulse Generator	22, 23
Modulation	50, 51	Ratio Meter	98, 99
Noise	28, 29	Reaction Meter (frequency)	107
Ohmmeters	34, 35	Reflections, Standard	114
Power	91	Regulated Power Supplies	79-82
Voltmeters	32-36	Resistance Tuned Audio Oscillator	8-16
Microwave Test Equipment	83-115	Resistors, Shunt	37

<i>Instrument</i>	<i>Page</i>	<i>Instrument</i>	<i>Page</i>
RMA Standards Tables	120, 121	Tunable Bolometer Mount	92
Rotary Phase Shifter	112	Tuners	111
Scaler	62	TV Aural, Video Monitors	50, 51
Secondary Frequency Standard	46, 47	UHF Signal Generators	68-71
Series Tees	110	Universal Bolometer Mount	92
SHF Test Set	74, 75	Universal Probe Carriage	104, 105
Shorts, Waveguide, Adjustable	115	Untuned Probe	106
Shorting Switch, Waveguide	115	Vacuum Tube Voltmeters:	
Shunt Resistors	37	Audio Frequency	32-36
Shunt Tees	110	Dc Voltage	34
Signal Generators:		Low Frequency	36
Audio Frequency	18-21	RF, VHF	32-35
SHF	72-75	Variable Flap Attenuator	87
Supersonic Frequency	18, 19	VHF Bridge	100, 101
UHF	68-71	VHF Detector	101
VHF	66, 67	VHF Signal Generator	66, 67
Slide Screw Tuner	111	VHF Vacuum Tube Voltmeter	35, 36
Slotted Sections	102-105	Video Test Oscillator	14, 15
Square Wave Generator	24	Voltage Divider	37
Stand, Waveguide	117	Voltage Multiplier	37
Standard Reflections, Waveguide	114	Voltmeters (See Vacuum Tube Voltmeters)	
Standards, Frequency and Time	46, 47, 54-58, 62	Waveform Analyzer	26, 27
Standing Wave Indicator	103	Waveguide:	
Sub-Sonic Test Oscillators	8-11, 13	Adjustable Shorts	115
Supersonic Signal Generator	18, 19	Adapters, to Coax	85
Sweep Oscillator	76, 77	Attenuators	87
T-Connectors	37	Broad Band Probe	106
Tables, RMA and JAN Standards	120, 121	Clamps	117
Tachometer Generator	52	Detector Mounts	94, 106
Tachometer Indicator	48, 49	Directional Couplers	82, 83
Tachometer Pickup (Optical)	52	Frequency Meter	48, 49
Telemeter Oscillator	9	Flanges	120
Tees: Series, Shunt and Hybrid	110	Phase Shifter	112
Terminations, Waveguide	113	Shorting Switch	115
Test Oscillators	8-16	Slotted Sections	104, 105
Test Set	74, 75	Standard Reflections	114
Thermistor Mount	93	Tees	110
Time Interval Meter	54, 55	Terminations	113
Transformers:		Transformers or Tuners	111
E-H Tuner	111	Waveguide Size Tables	120, 121
Slide Screw Tuner	111	Wide Band Amplifiers	40, 41
Traveling-Wave Tube Amplifiers	42, 43	X-Band Test Set	74, 75

INDEX BY INSTRUMENT MODEL NUMBERS



<i>Model</i>	<i>Description</i>	<i>Page</i>	<i>Model</i>	<i>Description</i>	<i>Page</i>
AC-4A	Decade Counter	60	205AG	Audio Signal Generator	18, 19
AC-10A	Binding Post	117	206A	Low Distortion Audio Signal Generator	20, 21
AC-10B	Binding Post	117	211A	Square Wave Generator	24
AC-16A	Cable Assembly	118	212A	Pulse Generator	22, 23
AC-16B	Cable Assembly	118	233A	Carrier Test Oscillator	16
AC-16C	Cable Assembly	118	281A	Waveguide to Coaxial Adapter	85
AC-16D	Cable Assembly	118	290A	Waveguide Cover to Choke Flange Adapter	85
AC-16E	Cable Assembly	118	300A	Harmonic Wave Analyzer	26, 27
AC-16F	Cable Assembly	118	330B	Noise and Distortion Analyzer	28, 29
AC-16K	Cable Assembly	118	330C	Noise and Distortion Analyzer	29
AC-16Q	Cable Assembly	118	330D	Noise and Distortion Analyzer	29
AC-17	End Frames	116	335B	Frequency and Modulation Monitor, FM	50, 51
AC-24	Waveguide Support Pedestal	117	335E	Frequency and Modulation Monitor, TV	50, 51
25 Series	Waveguide Supports	117	350A	Attenuator, 500 Ohm	30
AC-44 Series			350B	Attenuator, 600 Ohm	30
	Cabinets, Metal	116	360 Series	Low Pass Filters	86
46A-16A	Patch Cord	41	370 Series	Waveguide Attenuators, Fixed	87
46A-16B	Patch Cord	41	375A	Waveguide Variable Flap Attenuator	87
46A-95A	Panel Jack	41	380A	Waveguide Calibrated Variable Attenuator	87
46A-95B	Cable Plug	41	382A	Broadband Precision Waveguide Attenuator	88
46A-95C	Adapter, 50 Ohm	41	400AB	Vacuum Tube Voltmeter	36
46A-95D	Adapter for 410B VTVM	41	400D	Vacuum Tube Voltmeter	32, 33
46A-95E	Connector Sleeve	41	410B	High Frequency Vacuum Tube Voltmeter	34, 35
46A-95F	Adapter for 5XP Tube	41	415B	Standing Wave Indicator	102
46A-95G	Adapter for 511 Tektronix	41	416A	Ratio Meter	98, 99
AC-54A/B/C			417A	Vhf Detector	101
	Binding Post Insulators	117	420A	Wide Band Crystal Detector	106
AC-60A	Line Matching Transformer	117	421A	Waveguide Crystal Detector Mount	106
AC-60B	Bridging Transformer	117	430C	Microwave Power Meter	91
100D	Secondary Frequency Standard	46, 47	440A	Detector Mount	106
200AB	Audio Oscillator	8, 9	442B	Broadband Probe	106
200CD	Wide Range Oscillator	8, 9			
200I	Interpolation Oscillator	8, 9			
200T	Precision Telemeter Test Oscillator	8, 9			
201B	Audio Oscillator	12			
202A	Low Frequency Function Generator	10, 11			
202B	Low Frequency Oscillator	13			

<i>Model</i>	<i>Description</i>	<i>Page</i>	<i>Model</i>	<i>Description</i>	<i>Page</i>
444A	Broadband Probe, Untuned	106	608D	Vhf Signal Generator	66, 67
450A	Stabilized Laboratory Amplifier . . .	38	608A-16D	Terminated Output Cable	67
452A	Capacitive Voltage Divider	37	612A	Uhf Signal Generator	68, 69
452A-95A	Adapter for 410B VTVM	37	614A	Uhf Signal Generator	70, 71
453A	Capacitive Voltage Divider	37	616A	Uhf Signal Generator	70, 71
454A	Capacitive Voltage Divider	37	618B	Shf Signal Generator	72, 73
455A	Probe Coaxial "T" Connector	37	620A	Shf Signal Generator	72, 73
458A	Probe Coaxial "N" Connector	37	623B	Shf Test Set	74, 75
459A	D. C. Resistive Voltage Multiplier . .	37	624C	X Band Test Set	74, 75
460A	Wide Band Amplifier	40, 41	650A	Test Oscillator	14, 15
460B	Fast Pulse Amplifier	40, 41	670HM	Shf Oscillator	76, 77
470 Series	Shunt Resistors	37	710B	Regulated Power Supply	78
475B	Bolometer Mount, Tunable	92	711A	Laboratory Power Supply	79
476A	Bolometer Mount, Untuned	92	712B	Regulated Power Supply	80
477A	Coaxial Thermistor Mount	93	715A	Klystron Power Supply	81
485 Series	Waveguide Detector Mounts	94	717A	Klystron Power Supply	82
487A	Broadband Waveguide Thermistor Mount	93	750D/E	Waveguide Directional Coupler . . .	108
490A	Traveling-Wave Tube Amplifier Low Noise	42, 43	752A/C/D	Waveguide Directional Coupler . . .	108
491A	Traveling-Wave Tube Amplifier High Output	42, 43	803A	Vhf Bridge	100, 101
500B	Electronic Frequency Meter	48, 49	805A	Coaxial Slotted Section	102, 103
500C	Electronic Tachometer Indicator . . .	48, 49	805B	Coaxial Slotted Section	102
506A	Optical Tachometer Pickup	52	806B	Coaxial Slotted Section	102
508A	Tachometer Generator	52	809B	Universal Probe Carriage	104, 105
508B	Tachometer Generator	52	810A	Waveguide Slotted Section	105
512A	Frequency Converter	61	810B	Waveguide Slotted Section	105
512B	Frequency Converter	61	812-52	Cable, 200 Ohm	41
520A	High Speed Decade Scaler	62	840A	Waveguide Tee, Series	110
521A	Industrial Electronic Counter	59	841A	Waveguide Tee, Shunt	110
522B	Electronic Counter	54, 55	845A	Waveguide Tee, Hybrid	110
524B	Electronic Counter	56, 57, 58	870A	Waveguide Tuner, Slide Screw . . .	111
525A	Frequency Converter Unit	57, 58	880A	Waveguide Tuner, E-H	111
525B	Frequency Converter Unit	57, 58	885A	Waveguide Phase Shifter	112
526A	Video Amplifier Unit	57, 58	890A	Waveguide Horn	113
526B	Time Interval Unit	57, 58	910A	Waveguide Termination, Low Power	113
530A	Waveguide Frequency Meter	107	912A	Waveguide Termination, High Power	113
608C	Vhf Signal Generator	66, 67	914A	Waveguide Moving Load	114
			916 Series	Waveguide Standard Reflections . .	114
			920A	Waveguide Adjustable Short	115
			930A	Waveguide Shorting Switch	115



COMPLETE COVERAGE

In electronic test instruments, Hewlett-Packard gives you complete coverage several different ways.

In development—*hp* engineer teams are continually at work designing and producing accurate, helpful new instruments that meet and anticipate the demands of electronics.

In instrumentation—the *hp* line is the world's largest and most complete. You choose from over 250 instruments the ones that provide exactly the measuring coverage you require.

In frequency coverage—*hp* makes nearly every kind of useful electronic test instrument. And, for almost all

useful frequencies, too. For example, *hp* signal generators offer solid frequency coverage from 10 to 11,000 MC; *hp* voltmeters from 2 to 700,000,000 cps, oscillators from 0.008 to 10,000,000 cps.

In personal service—*hp* has selected the best independent organizations to give you personal help with measuring problems. Electronics specialists—men trained by Hewlett-Packard—save you time by helping select the exact *hp* instrumentation you need—and following through to be sure the equipment is properly utilized to serve you best. These men are located in major business centers—as near as your telephone. Call them when you need personal help,—in your plant, today.

Call the nearest *hp* sales and service representative for personal help with your measuring problems

Albuquerque, New Mexico
Neely Enterprises
107 Washington St. S.E.
Albuquerque 5-5586

Asbury Park, New Jersey
I. E. Robinson Company
702 Mattison Avenue
DUnkirk 9-2404

Atlanta 5, Georgia
Bivins & Caldwell
267 East Paces Ferry Road, N.E.
CHerokee 7522

Bogota, New Jersey
R. M. C. Associates
114 East Main Street
DLiamond 2-5343

Bridgeport 8, Connecticut
Yewell Associates, Inc.
1101 East Main Street
FOrrest 6-3456

Chicago 40, Illinois
Alfred Crossley Associates, Inc.
4501 North Ravenswood Ave.
UPtown 8-1141

Cleveland 15, Ohio
M. P. Odell Co.
2536 Euclid Ave.
PRospect 1-6171

Dallas 9, Texas
Earl Lipscomb Associates
P. O. Box 7084
ELmhurst 5345

Dayton 9, Ohio
Alfred Crossley Associates, Inc.
53 Park Avenue
OXmoor 3594

Denver 3, Colorado
Hytronic Measurements Associates
446 Broadway
SHerman 4-2501

Detroit 35, Michigan
S. Sterling Company
15310 West McNichols Rd.
BRoadway 3-2900

Fort Myers, Florida
Arthur Lynch & Associates
P. O. Box 466
Edison 4-4431

Harrisburg, Pennsylvania
I. E. Robinson Company
37A Thomas Street
Harrisburg 8-9054

High Point, North Carolina
Bivins & Caldwell
Security Bank Bldg.
High Point 3672

Houston 5, Texas
Earl Lipscomb Associates
P. O. Box 6573
JACKSON 4-9303

Kansas City 30, Missouri
Harris-Hanson Company
7916 Paseo Avenue
HILand 6744

Los Angeles 46, California
Neely Enterprises
7422 Melrose Ave.
WEstber 3-9201

New York 21, New York
R. M. C. Associates
170 East 80th Street
TRafalgar 9-2023

Philadelphia (Upper Darby), Pennsylvania
I. E. Robinson Company
7404 West Chester Pike
SHerwood 8-1294

Phoenix, Arizona
Neely Enterprises
641 East Missouri
CRestwood 4-5431

Pittsburgh 21, Pennsylvania
M. P. Odell Co.
750 Penn Avenue
FRemont 1-1231

Sacramento 14, California
Neely Enterprises
1317 - 15th Street
GILbert 2-8901

San Diego 6, California
Neely Enterprises
1029 Rosecrans Street
ACademy 3-8106

San Francisco 18, California
Neely Enterprises
2830 Geary Blvd.
WAlnut 1-2361

Seattle 99, Washington
Ron Merritt Company
120 West Thomas Street
GARfield 6644

St. Louis 9, Missouri
Harris-Hanson Company
5506 S. Kingshighway
SWEetbriar 5584-85

St. Paul 14, Minnesota
Alfred Crossley Associates, Inc.
2388 University Avenue
PRior 4955

Stroudsburg, Pennsylvania
I. E. Robinson Company
P. O. Box 68
Stroudsburg 1519

Syracuse 2, New York
J. D. Ryerson Associates, Inc.
412 East Genesee St.
SYracuse 76-8344

Toronto 10, Ontario, Canada
Atlas Radio Corporation, Ltd.
50 Wingold Avenue
RUssell 1-6174

Waltham 54, Massachusetts
Yewell Associates, Inc.
751 Main Street
WAltham 5-7420

Washington 9, D. C.
Horman Associates
2017 S Street, N. W.
DEacatur 2-5705

HEWLETT-PACKARD COMPANY

275 PAGE MILL ROAD, PALO ALTO, CALIFORNIA, U. S. A.

CABLE "HEWPACK"